

**М. АХМЕДОВ**, Н. АБДУРАХМАНОВА, М. ЖУМАЕВ

# МАТЕМАТИКА

ЖАЛПЫ ОРТА БІЛІМ БЕРЕТІН МЕКТЕПТЕРДІҢ  
1-СЫНЫБЫНА АРНАЛҒАН ОҚУЛЫҚ

Он үшінші басылым

Өзбекстан Республикасы Халыққа білім беру  
министрлігі бекіткен

«TURON-IQBOL»  
ТАШКЕНТ – 2019

### Жаапты редактор:

**Б. Абдуллаева** – Низами атындағы ТМПУ-дің ғылыми жұмыстар және инновациялар бойынша проректор, педагогика ғылымдарының докторы, профессор;

### Пікір жазғандар:

**А. Садикова** – Низами атындағы ТМПУ-дің доценті, педагогика ғылымдарының кандидаты;

**З. Жуманова** – Республика білім орталығы Бастауыш білім бөлімінің бастығы;

**Н. Рузикулова** – Низами атындағы ТМПУ-дің тірек докторанты;

**Л. Гойибова** – Ташкент қаласы, Алмазар ауданына қарасты 196-жалпы орта білім беретін мектептің бастауыш сынып оқытушысы

### Шартты белгілер:



– ауызша орындауға арналған жаттығулар



– бос торкөздерге керекті сандарды немесе белгілерді қою



– жазбаша орындауға арналған жаттығулар



– мультимедиялық қосымша



– үлкен, кіші, тең белгілерін қою



– үй тапсырмасы үшін тапсырмалар



– ойлап тап!



– сабақтың аяқталуы

**Республикалық мақсатты кітап қорының қаржылары есебінен басылды.**

# Заттардың жинақтары. 1-ден 10-ға дейінгі болған сандар. 10 арасында қосу мен азайту амалдары



## Заттар мен олардың қасиеттері



# Ұқсастық пен өзгешелік

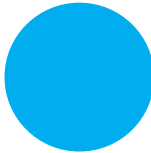
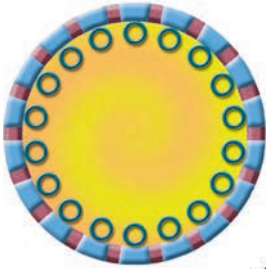
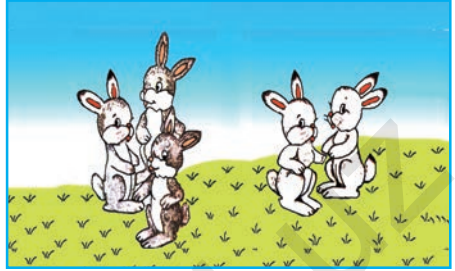





# Заттардың өлшемдері бойынша салыстыру

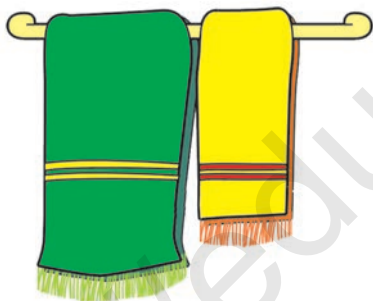

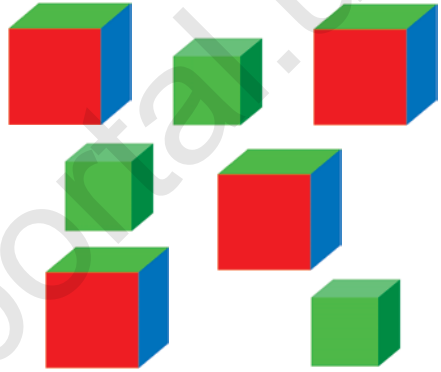
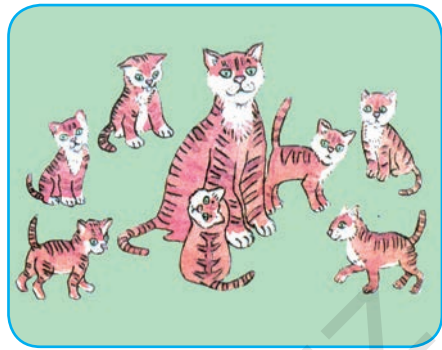
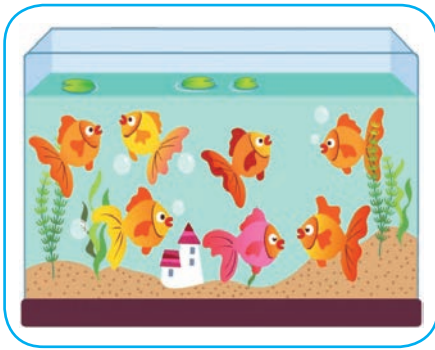

# Заттардың өзара орналасуы

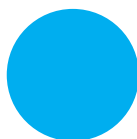
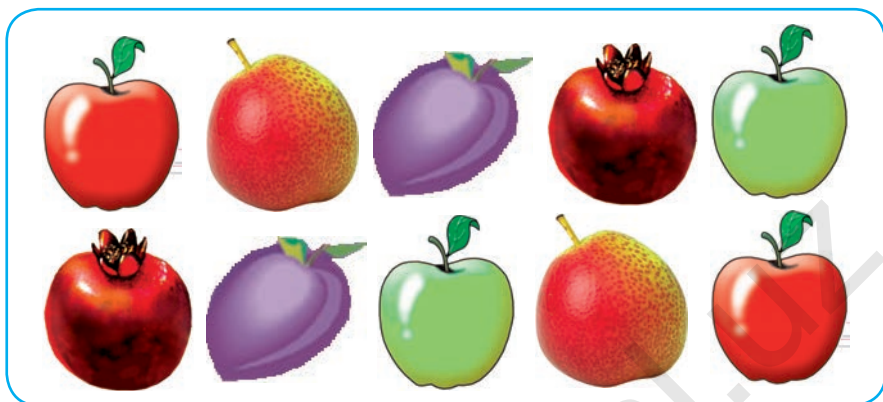

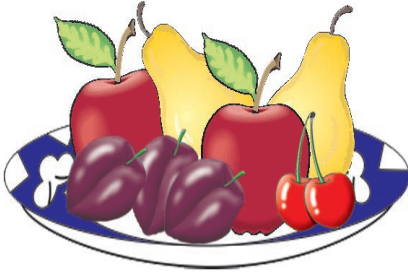



# Заттарды қасиеттері бойынша жинақтарға ажырату

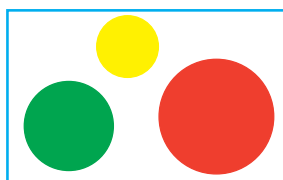
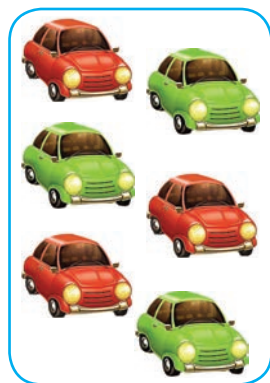
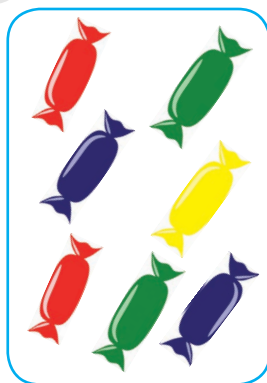
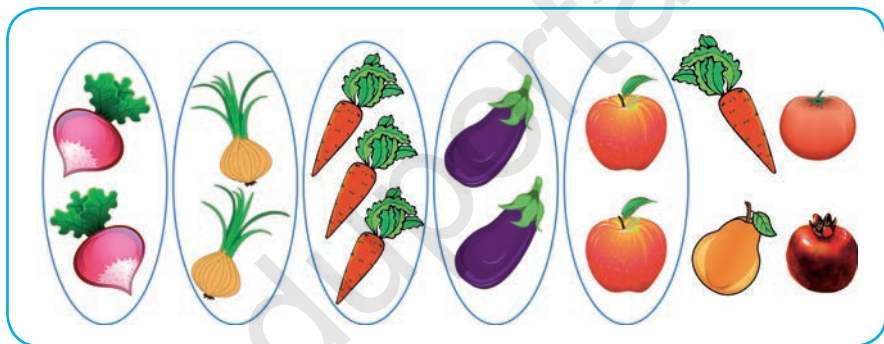
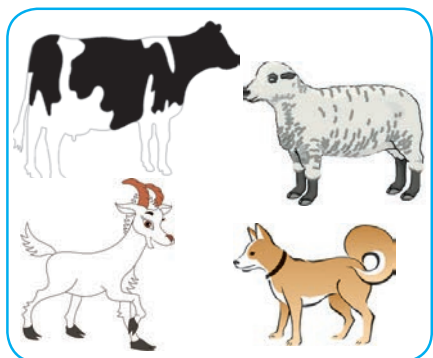



# Жинақтарды құраған заттар саны бойынша салыстыру

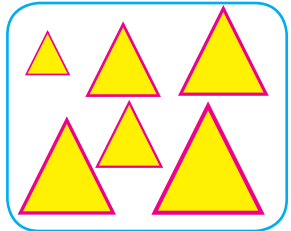
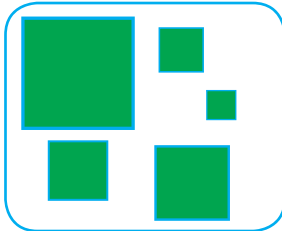
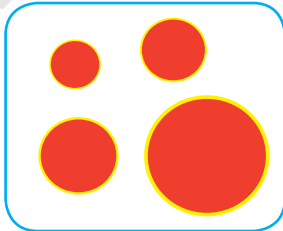
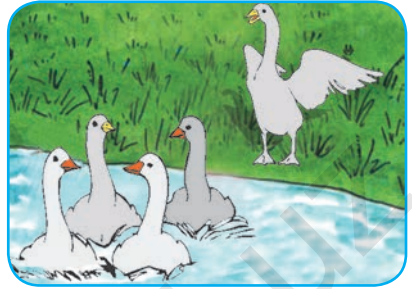



# 1-ден 10-ға дейінгі болған сандардың аталуы

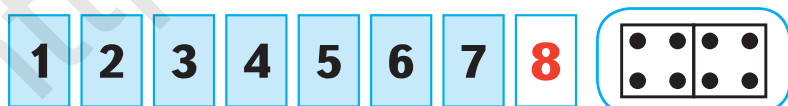
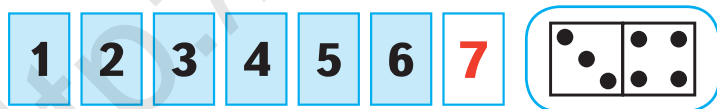
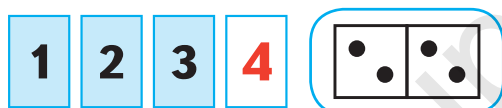
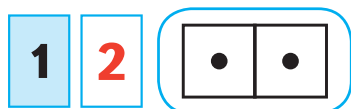
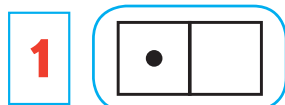
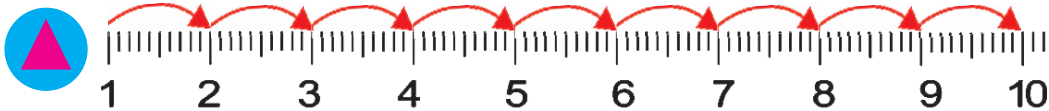



# Заттардың санағы мен тізбектілігі



1



2



3



4

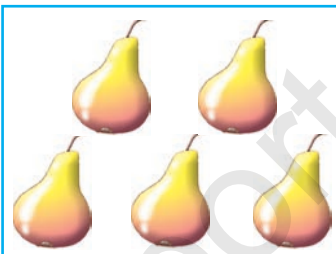

5

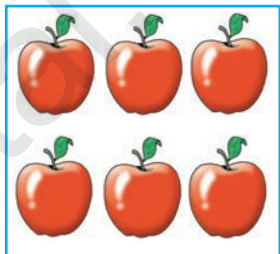

6



7

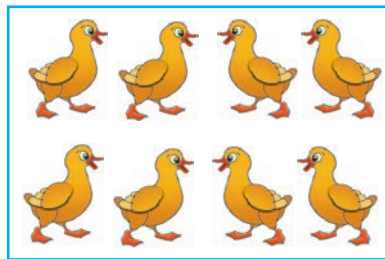

8



9

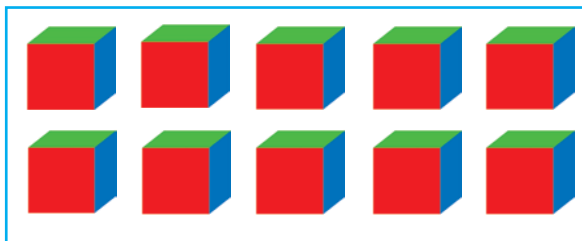

10





1.



2.

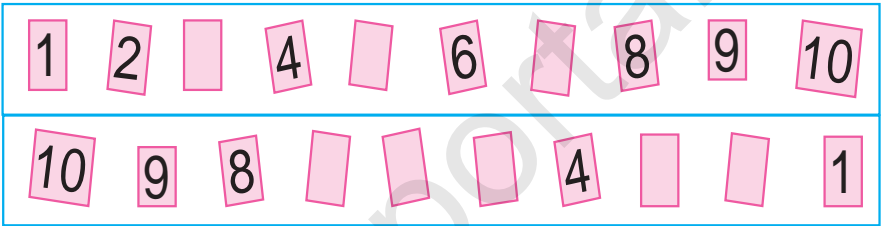

3.

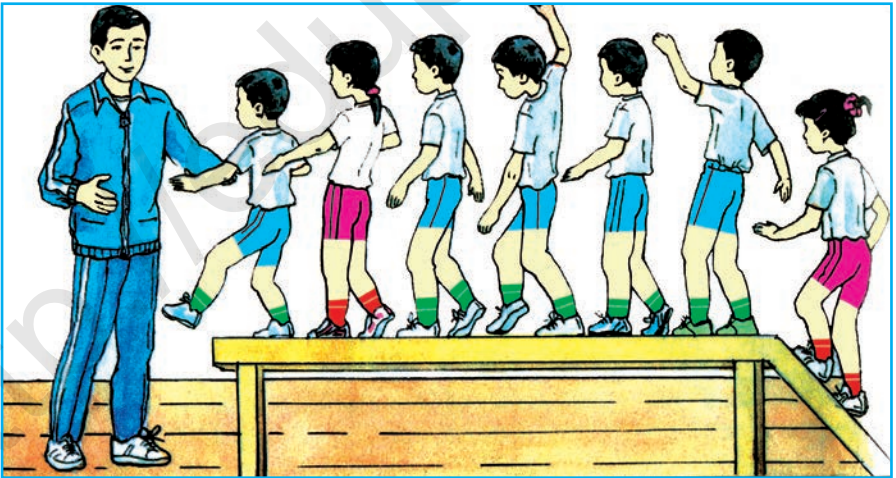

4.

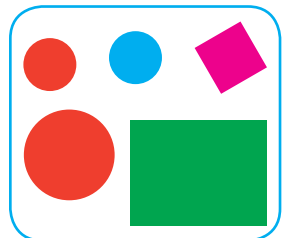
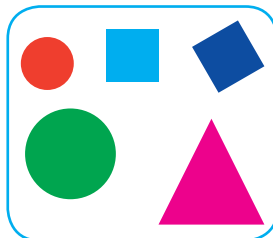
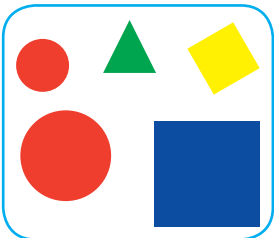

# Үлкен, кіші, тең түсініктері

>, <, =



1.

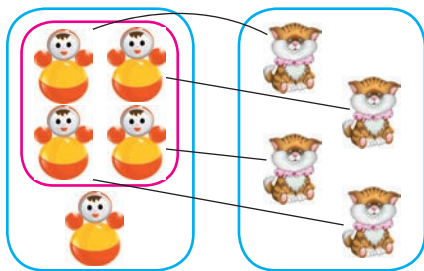

$4 + 1 > 3 + 1$

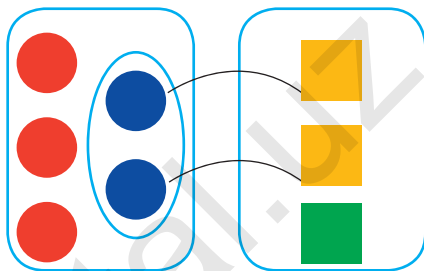

$3 + 2 > 2 + 1$

2.

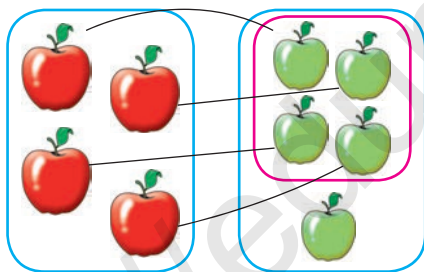

$4 < 5$

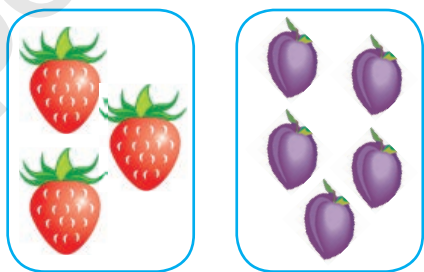

3.

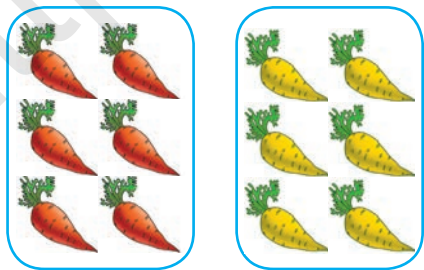

$6 = 6$

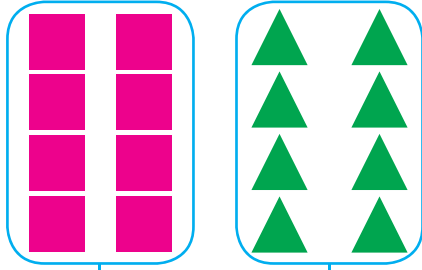





# 1-ден 5-ке дейін болған сандарды санау

## 1 саны



1.



2.

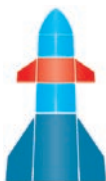

3.



4.



5.



1



# 2 саны



1.

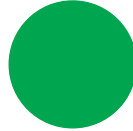

2.



1



3.



2

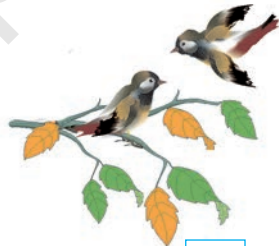

4.

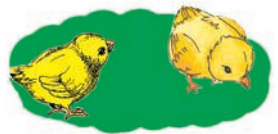

5.



2



### 3 саны



1.



2.

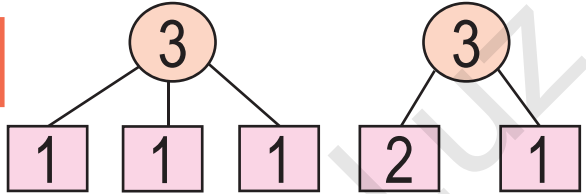

3.



$$2 + \square = \square$$

$$\square - 1 = 2$$

4.



$$2 + 1 = \square$$

$$3 - 1 = \square$$

$$1 + 1 = 2$$

$$2 + 1 = 3$$

$$1 + 2 = 3$$

$$2 - 1 = 1$$

$$3 - 1 = 2$$

$$3 - 2 = 1$$





# 4 саны

1 2 3 4

4 4



1.



$$3 + 1 = 4$$

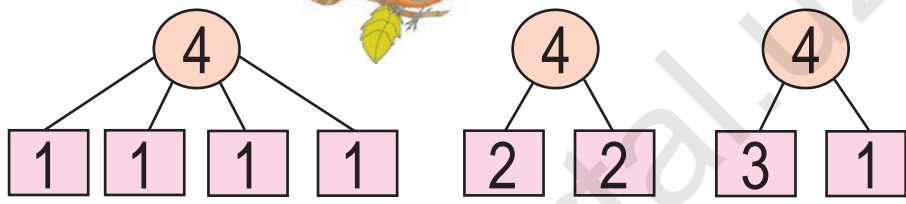

2.



$$3 + \square = 4$$

$$1 + \square = 4$$



3.

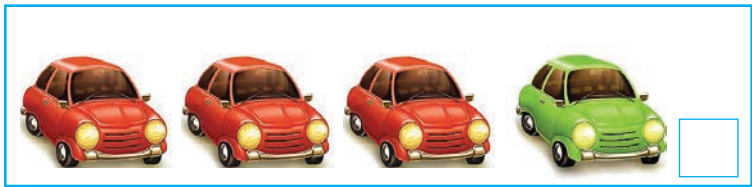

$3 + 1 = 4$	$1 + 3 = 4$	$2 + 2 = 4$
$4 - 1 = 3$	$4 - 2 = 2$	$4 - 3 = 1$





# 5 саны

1 2 3 4 5

5 5

$$4 + 1 = 5$$



1.

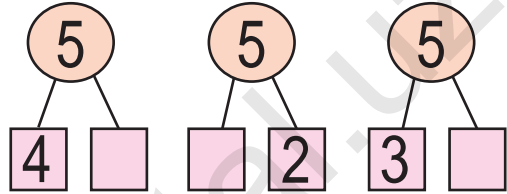

2.

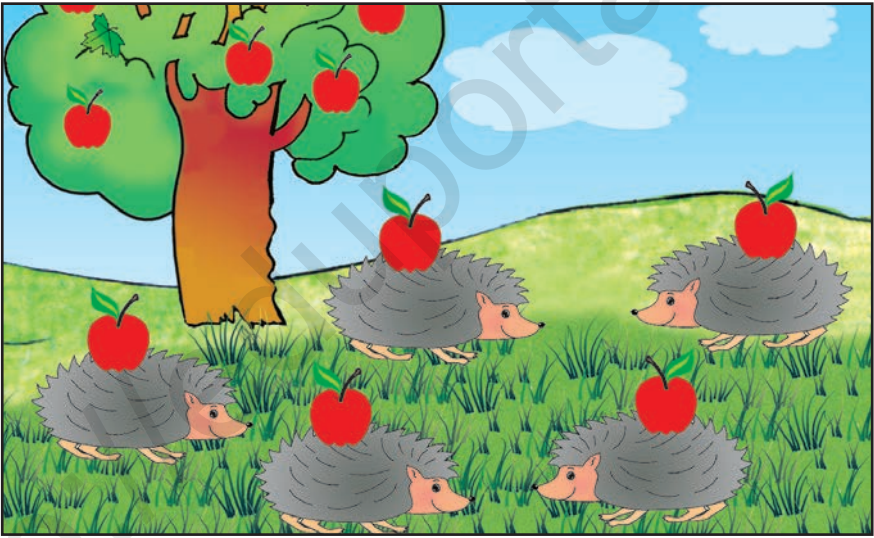

$$3 + 2 = \square$$

$$2 + 3 = \square$$



3.

$$2 \square 3$$

$$2 \square 2$$

$$4 \square 3$$

$$4 \square 2$$



4.

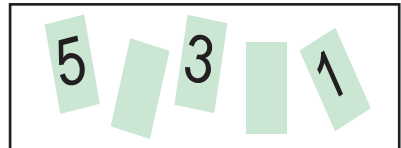

5.

$$4 + 1 = \square$$

$$3 + 2 = \square$$

$$2 + 3 = \square$$

$$2 + 2 = \square$$

$$5 - 3 = \square$$

$$5 - 2 = \square$$



# 5-тің ішінде =, +, - белгілерінен пайдаланып, нәтижелерді жазу

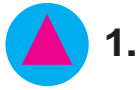

1.

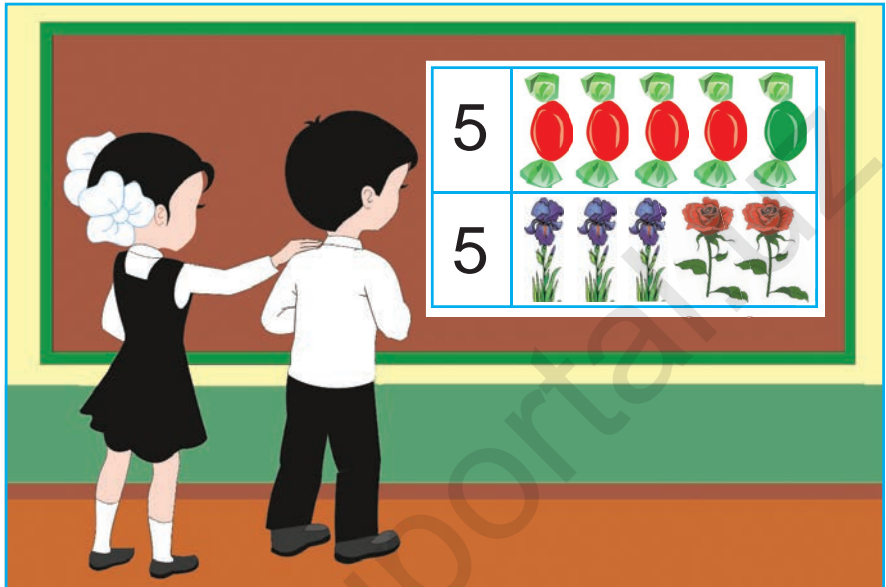

2.



3.

$5 \square 4$     |     $2 \square 5$     |     $4 \square 5$     |     $5 \square 5$

4.

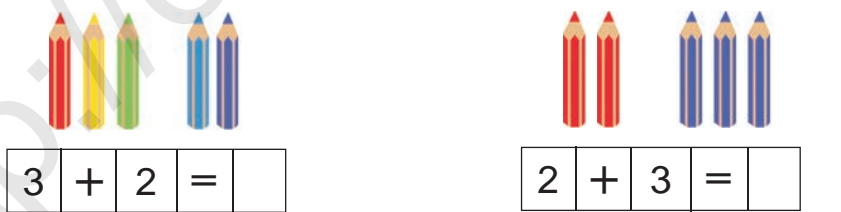

$3 + 2 = \square$

$2 + 3 = \square$

5.

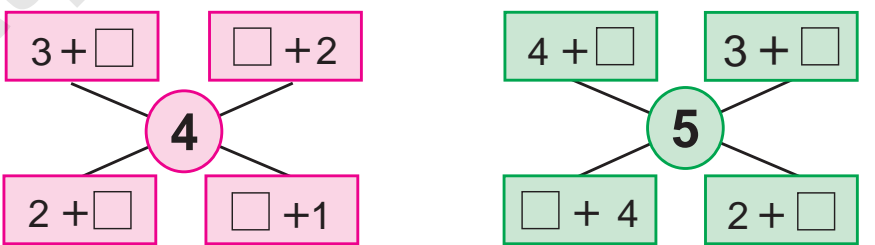

$4 + 1 = 5$      $1 + 4 = 5$      $3 + 2 = 5$      $2 + 3 = 5$





6.

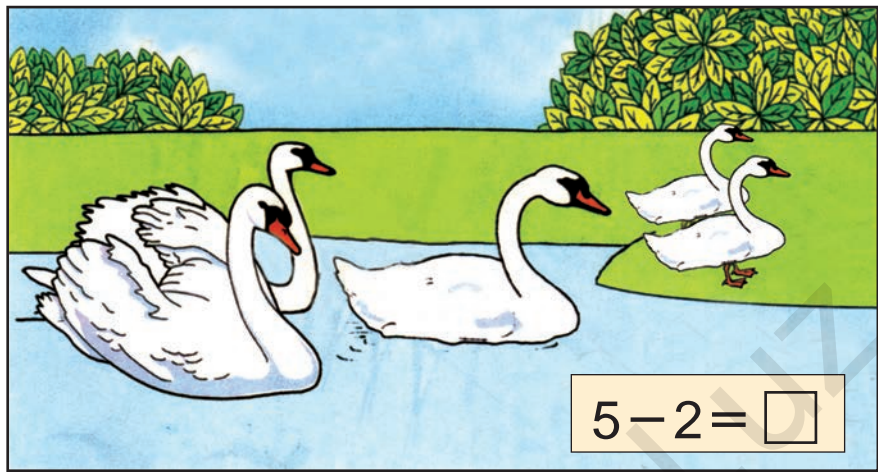

$$5 - 2 = \square$$



7.



$$5 - 1 = \square$$

$$5 - 4 = \square$$



8.



$$3 + 2 = \square$$

$$5 - 2 = \square$$



9.

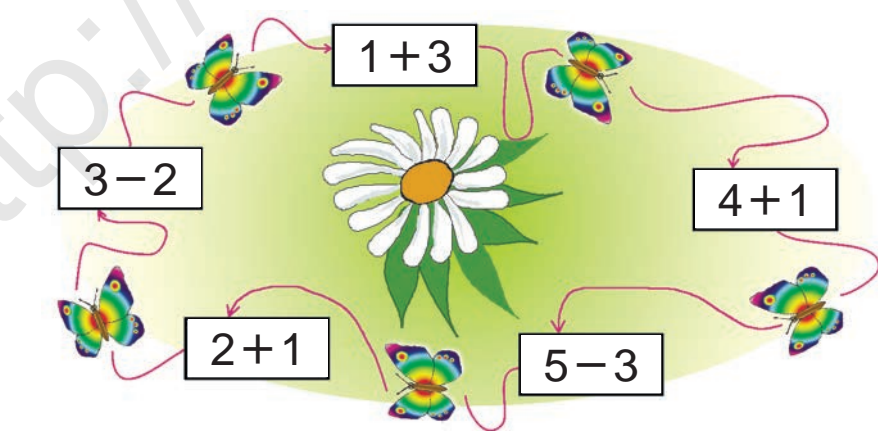

$$1 + 3$$

$$3 - 2$$

$$4 + 1$$

$$2 + 1$$

$$5 - 3$$



$$5 - 1 = 4 \quad 5 - 2 = 3 \quad 5 - 3 = 2 \quad 5 - 4 = 1$$



# 6-дан 9-ға дейінгі болған сандарды ретте

## 6 саны

1 2 3 4 5 6

6 6

$$5 + 1 = 6$$



1.

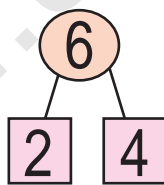
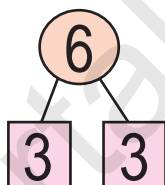
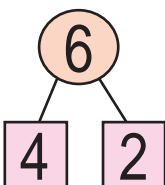

2.



$$5 + \square = 6$$

$$1 + \square = 6$$

3.

2 3 4

4

5



4.





7 саны



1 2 3 4 5 6 7

$$6 + 1 = 7$$



1.

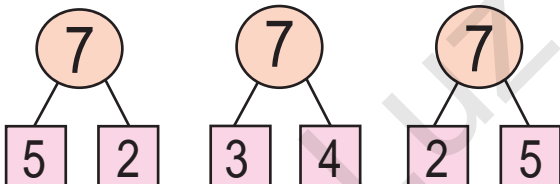

2.



3.

3 4 5    [ ] 5 [ ]    [ ] 6 [ ]



4.

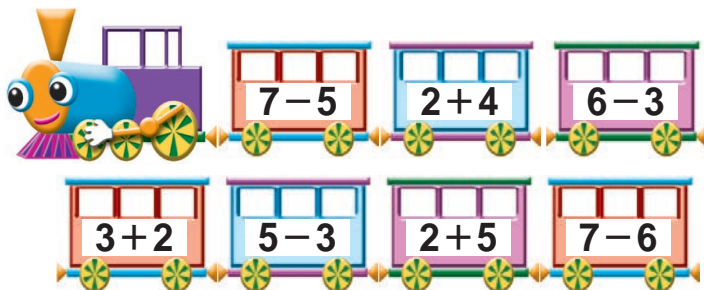



# 8 саны

1 2 3 4 5 6 7 8

8

8

$$7 + 1 = 8$$

1.

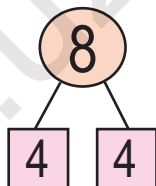
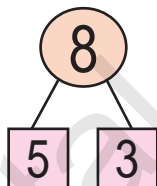
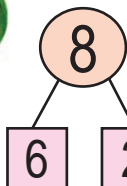

2.

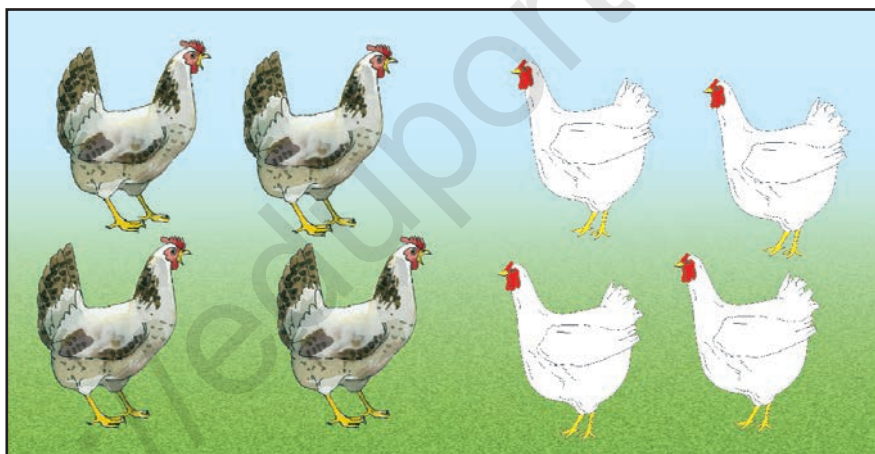

$$\square + \square = \square$$

$$8 - \square = \square$$

$$3. \quad 7 + 1 = 8$$

$$8 - 1 = \square$$

$$5 + 3 = 8$$

$$8 - 3 = \square$$

$$4 + 4 = 8$$

$$8 - 4 = \square$$

4.

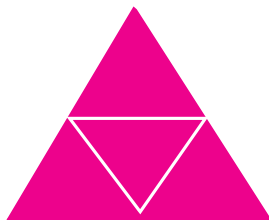





# 9 саны

1 2 3 4 5 6 7 8 9

9

9

$$8 + 1 = 9$$



1.

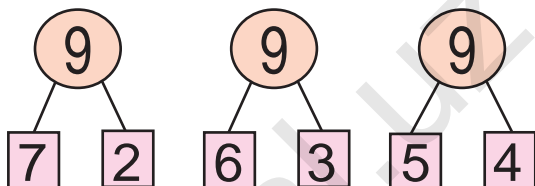

2.



3.

$7 + 2 = 9$

$6 + 3 = 9$

$4 + 5 = 9$

$9 - 2 = \square$

$9 - 3 = \square$

$9 - 4 = \square$



4.

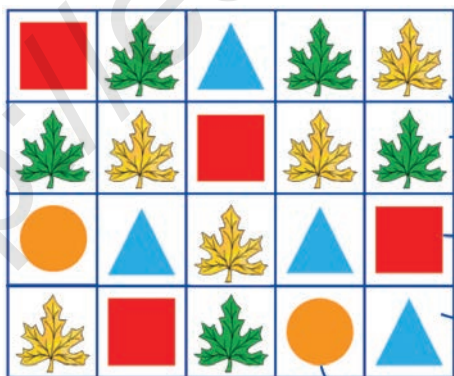

$\square + 4 = 9$

$\square + 3 = 8$

$\square + 3 = 7$

$\square + 2 = 6$

$\square + 3 = 5$



5.

9	1	2	3	4	5	6	7	8
	8							



6.



$6 + 3 = 9$

$9 - 6 = \square$

$9 - 3 = \square$

7.

$2 + \square$

$\square + 1$

$\square + 2$

$1 + \square$

8

9

$1 + \square$

$\square + 2$

$\square + 1$

$3 + \square$

8.

$5 + 3 = 8$

$3 + 6 = 9$

$7 + 2 = 9$

$8 - 5 = \square$

$9 - 3 = \square$

$9 - 7 = \square$

9.



$8 + \square = 9$

$9 - \square = 8$

10.

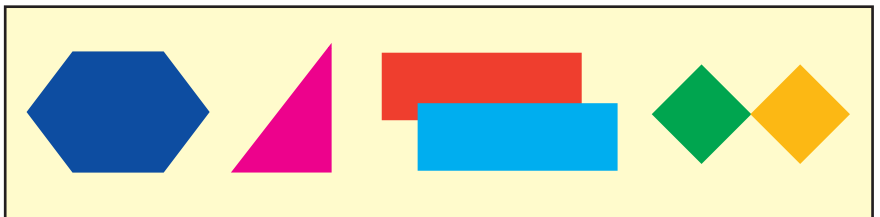



# 0 саны мен цифрасы

1 2 3 4 5 6 7 8 9



9 8       1



1.



3



2



1



0

2.



5



4



3



2



1



0



3.

$2 - 2 = 0$

$6 - 6 = 0$

$7 - 7 = 0$

4.



3



$3 - 3 = 0$



5



$5 - 5 = 0$



5.





# 10 саны

1 2 3 4 5 6 7 8 9 10

10 10



$$9 + 1 = 10$$



1.

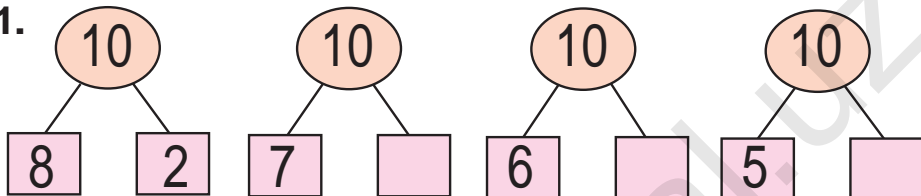

2.



? дана



3.

$$8 + 2 = 10$$

$$10 - \square = 8$$

$$7 + 3 = 10$$

$$10 - \square = 3$$

$$6 + 4 = 10$$

$$10 - \square = 6$$



4.



5.

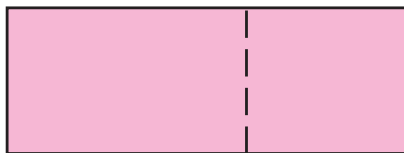
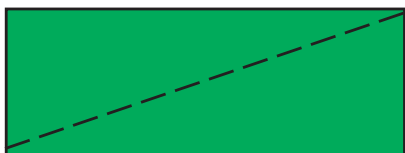

# 10 ішінде =, +, - белгілерінен пайдаланып, нәтижелерді жазу



1.

$$5 \quad +1 \quad \square \quad +2 \quad \square \quad +1 \quad 9$$

$$9 \quad -2 \quad \square \quad -1 \quad \square \quad -2 \quad 4$$



2.

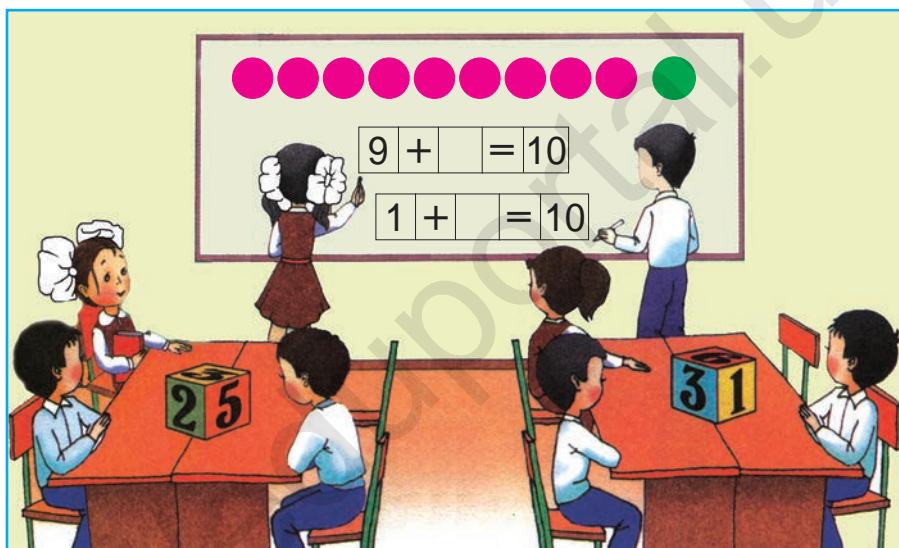

3.

$$9+1$$

$$8-2$$

$$6-4$$

$$5+5$$

$$4+6$$

$$7-3$$

$$9-2$$

$$3+7$$



4.

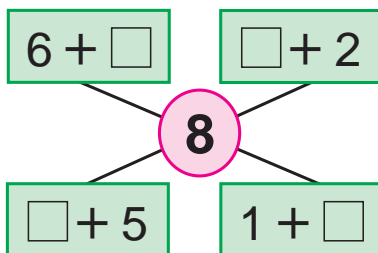
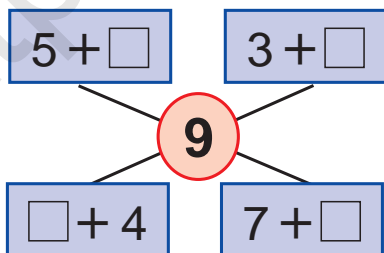

5.

$$5+4 \square 10$$

$$9-2 \square 7$$

$$8-3 \square 6$$





$$6+4 \square 3$$

$$5+2 \square 8$$

$$7-3 \square 4$$



6.

 +  = 10									
	9		2		4		5		1
		7		3		6		8	

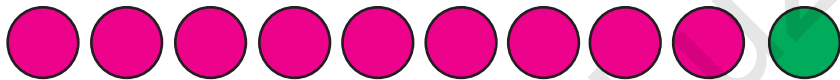

7.

$9 \square 8$        $7 \square 8$        $6 \square 6$        $9 \square 3$   
 $8 \square 9$        $8 \square 7$        $9 \square 9$        $3 \square 9$

8.



$6 + \square = \square$

$\square + 4 = \square$

9.

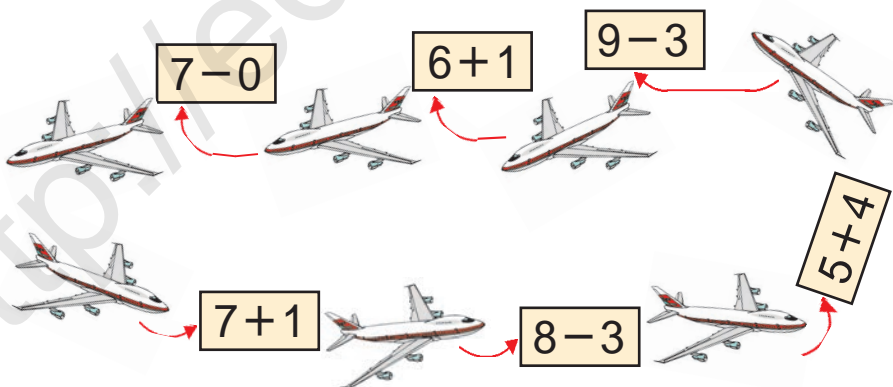

10.

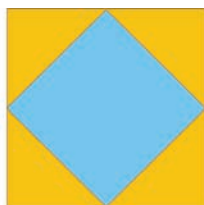

# 1-ден 10-ға дейінгі болған сандарды салыстыру

1.

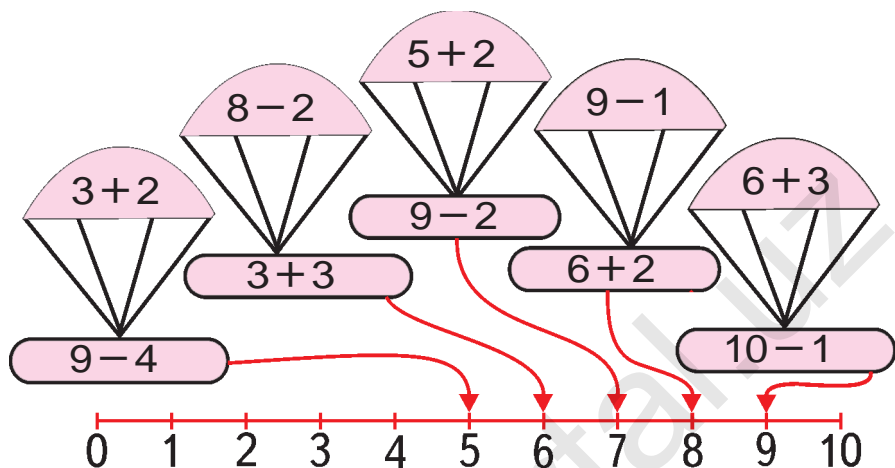

2.

=, ≠

Comparison task with four groups of vegetables:

- Group 1: 6 watermelons. Blue square below.
- Group 2: 6 pumpkins. Blue square below.
- Group 3: 5 red peppers. Blue square below.
- Group 4: 4 green peppers. Blue square below.

3.

=, ≠

Comparison task with four groups of geometric shapes:

- Group 1: 6 blue squares. Blue square below.
- Group 2: 7 red circles. Blue square below.
- Group 3: 6 green triangles. Blue square below.
- Group 4: 8 yellow rectangles. Blue square below.



# Уақыт елестері



1.



2.



3.  $4 + \square = 7$

$5 + \square = 8$

$1 + \square = 9$

$5 - \square = 2$

$5 - \square = 4$

$6 - \square = 2$

4.

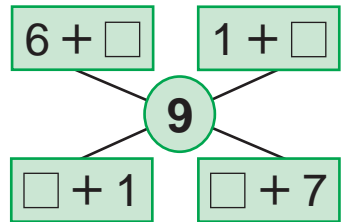
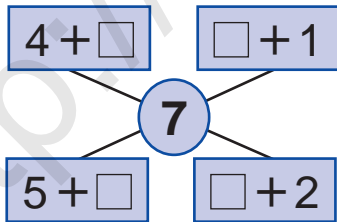

5.

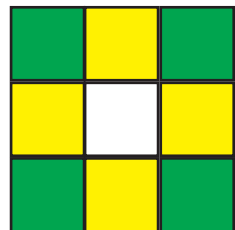
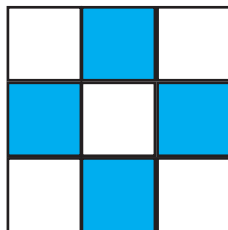
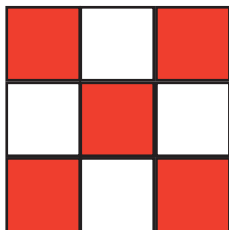

# Апта. Апта күндері және санағы



1.



2.

$5 \square 4$

$9 \square 8$

$9 \square 5$

$7 \square 6$

$7 \square 8$

$8 \square 7$

$9 \square 9$

$6 \square 7$



3.

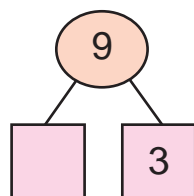
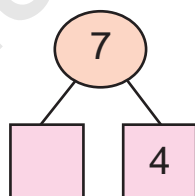
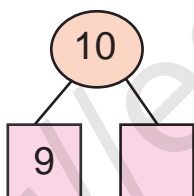

4.

$9 + 1 = 10$

$8 + 2 = 10$

$7 + 3 = 10$

$10 - 1 = \square$

$10 - 2 = \square$

$10 - 3 = \square$



5.

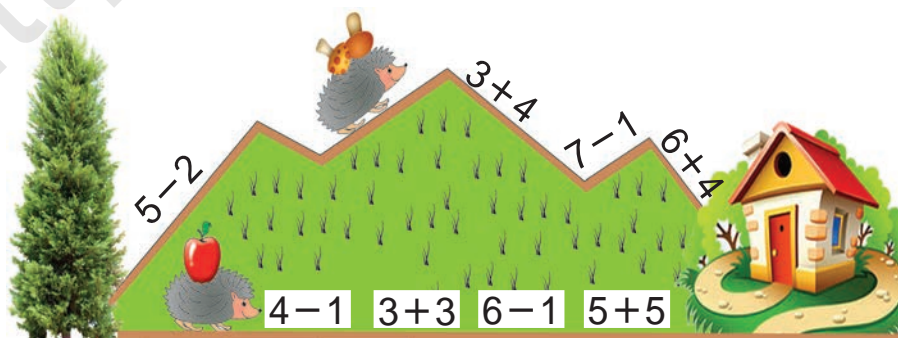

# Жүп және тақ сандар



1.



$$2 + 2 + 2 + 2 + 2$$



2.

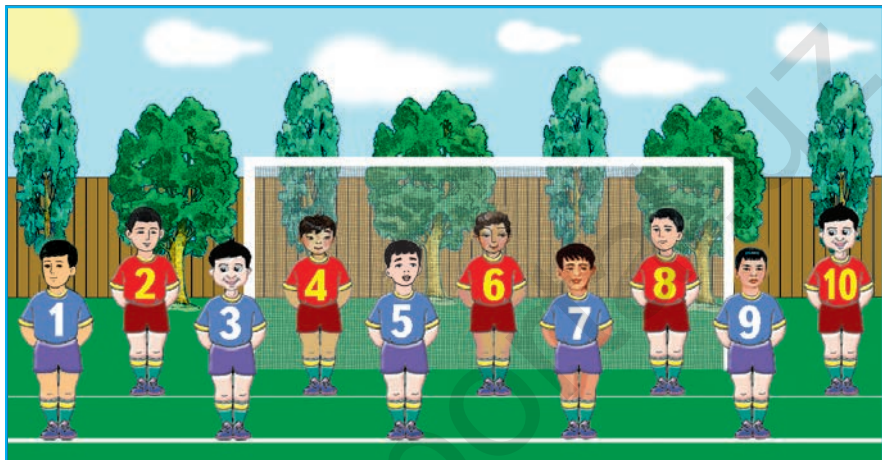

1		3		5		7		9	
	2		4		6		8		10



3.



1



2



3



4



5



6



7



8



9



4.

$8 - 3$

$5 + 4$

$9 - 7$

$2 + 4$

$2 + 3$

$7 - 2$

$2 + 1$

$9 - 6$





# Нүкте. Түзу сызық кесіндісі. Сынық сызық пен қисық сызық



1.

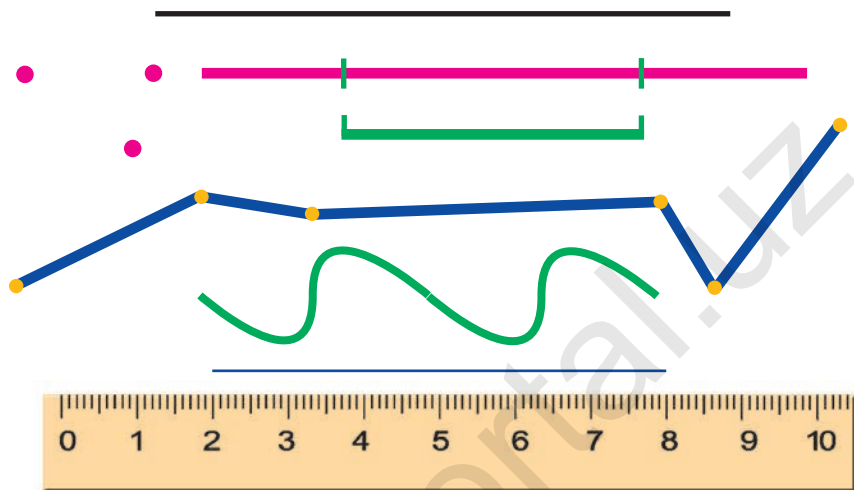

2.  $4+2$                        $6+2$                        $9-5$                        $2+3$   
 $8+2$                        $4-3$                        $2+1$                        $5-4$



3.

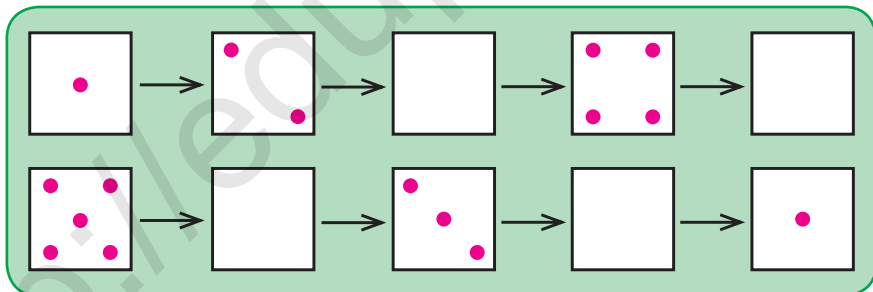

4.



$$3 + \square = \square$$

$$\square + 4 = \square$$



5.



6. Бұл сызықтардың қай бірін сынық сызық деп атау мүмкін?

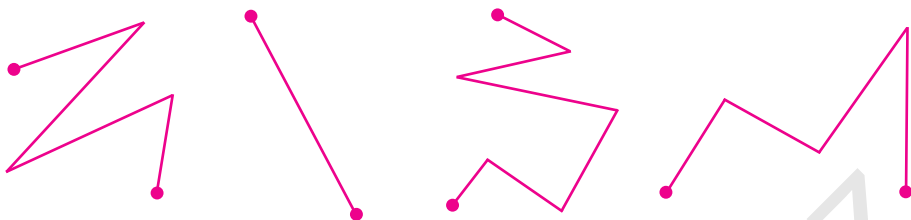

7.

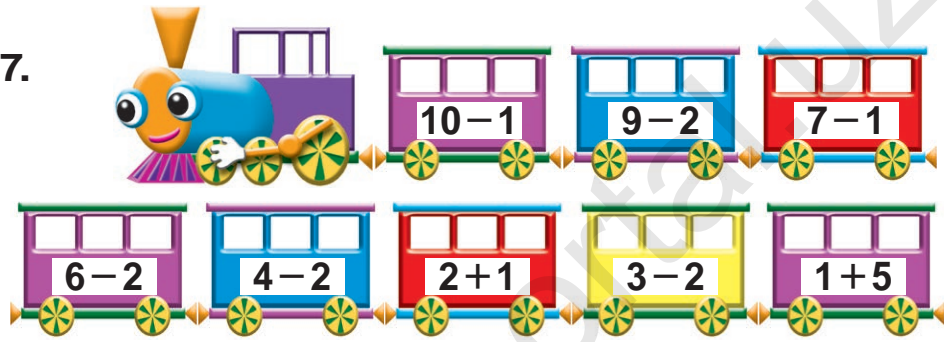

8. Берілген кесінділерді дәптеріңе сыз. Ұзындығы тең болған кесінділерді тап:

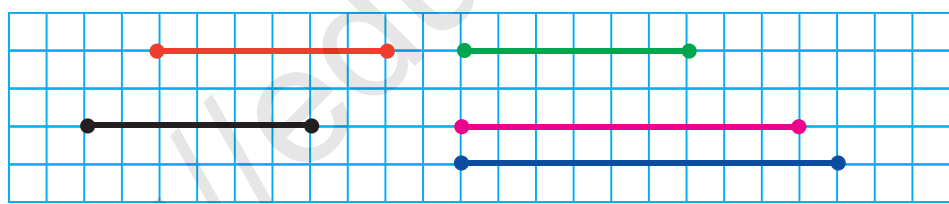

9.  $8+1$        $9-2$        $6+3$        $7+3$   
 $9-3$        $5+4$        $8-4$        $9+1$

10. Есеп құрастыр және оны шеш:



$10 - 3 = 10 - 2 - 1$

# Нөл қатысқан сандарды қосу және азайту



1.



$$5 + 0 = 5$$

$$\square + 0$$

$$\square - 0$$



$$6 - 0 = 6$$



2.  $0 + 5 = 5$

$3 - \square = 3$

$6 + 0 = \square$

$9 - 0 = 9$

$8 + \square = 8$

$2 - 0 = \square$



3. Есеп құрастыр және оны шеш:



? дана



4.  $8 + 2 \square 10$

$6 - 4 \square 9$

$3 + 5 \square 8$

$2 + 5 \square 10$

$6 + 0 \square 8$

$8 - 3 \square 7$



5. Есепте:

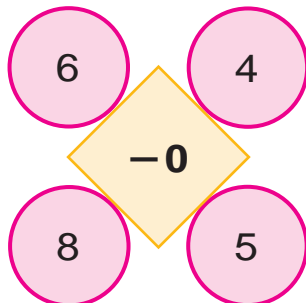
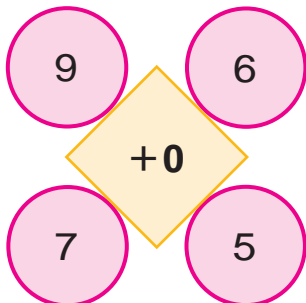

# Қосу және азайту амалдарын орындау тәсілдері



1.

1	2	3	4	5	6	7	8	9	10
10	9	8	7	6	5	4	3	2	1



2.

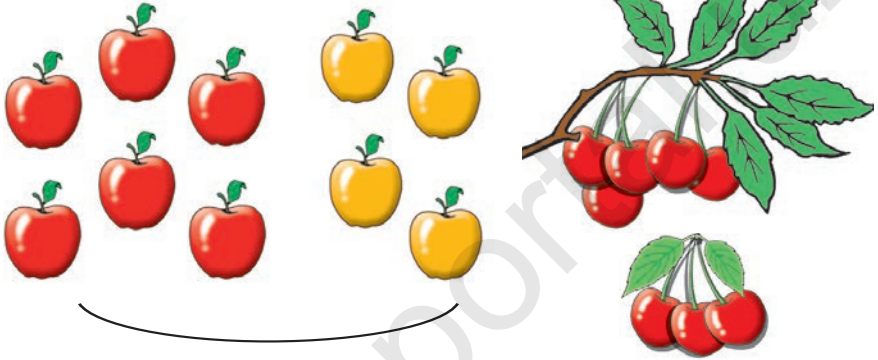

$$6 + 4 = \square \square$$

$$8 - 3 = \square$$



3.

$6 \square 3$

$8 \square 4$

$9 \square 9$

$10 \square 5$



4.

$5 - \square = 4$   
 $3 + \square = 4$   
 $4 + \square = 7$   
 $7 - \square = 3$   
 $3 + \square = 5$



# Қосу амалының мүшелері

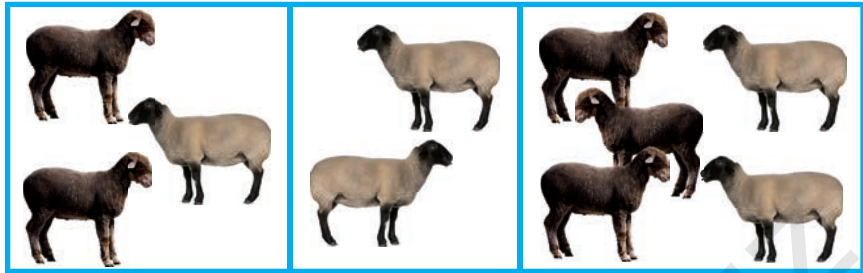

3

2

5

3 – қосылғыш 2 – қосылғыш 5 – қосынды

3 пен 2-нің қосындысы 5-ке тең.  
 3 – қосылғыш  
 2 – қосылғыш  
 5 – қосынды **3+2** – қосынды.  
 Қосу мүшелерімен оның компоненттері



2.  $5+2$                        $1+7$                        $3+2$                        $4+3$   
 $3+5$                        $7+2$                        $1+3$                        $5+4$

3. Сурет негізінде есеп құрастыр және оны шеш:

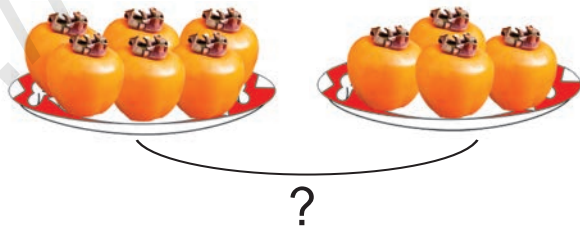

4.

Қосылғыш	3	5	6	8	3	7	6
Қосылғыш	5	4	1	2	3	3	0
Қосынды							





# Азайтудың мүшелері

1.



6



2



4

6 – азайғыш

2 – азайтқыш

4 – айырма

6 мен 2-нің айырмасы 4-ке тең.

6 — азайғыш

2 — азайтқыш

4 — айырма

**6-2** – айырма.

Азайтудың мүшелері оның компоненттері болады.

2.



$6 - 2 = \square$

3. Есеп құрастыр және оны шеш:

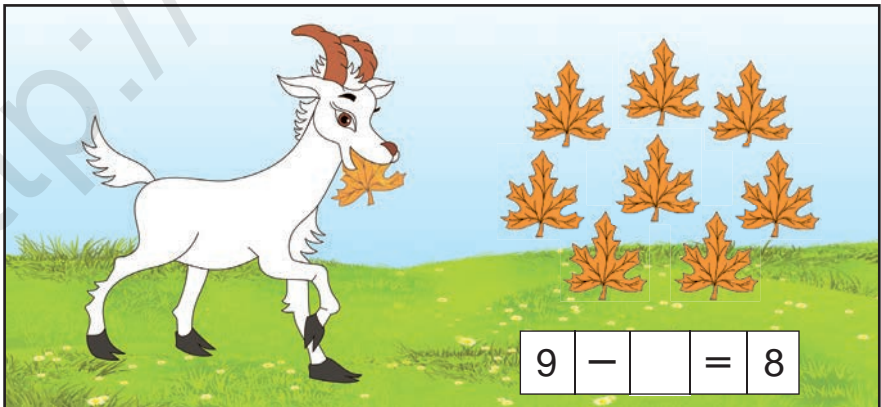

$9 - \square = 8$

4.  $7 - 6$

$5 - 5$

$7 - 2$

$10 - 8$

$9 - 3$

$8 - 4$

$6 - 5$

$10 - 9$

# Қосу мен азайту амалдарының мағынасы



1.

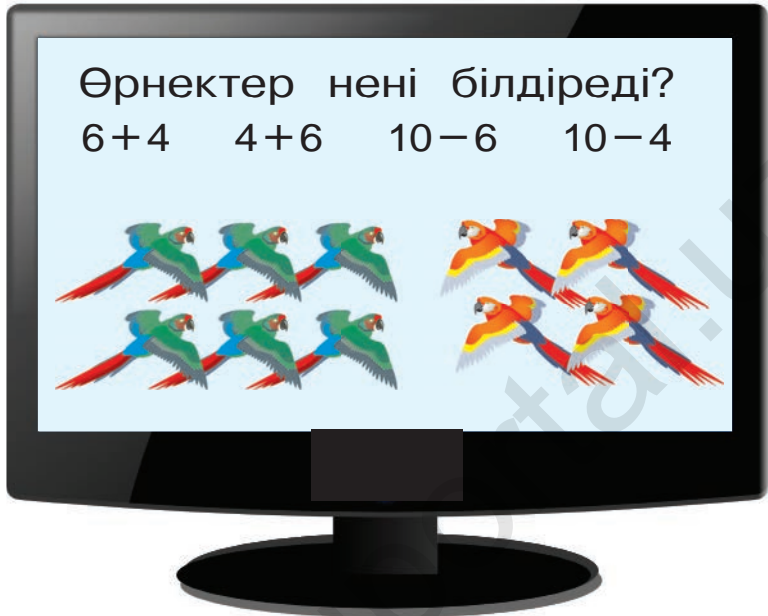

2.

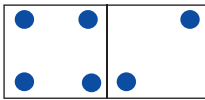

$$\underline{4 + 2 = 6}$$

$$6 - 2 = \square$$

$$6 - 4 = \square$$

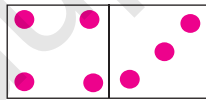

$$\underline{4 + 3 = \square}$$

$$\square - 4 = \square$$

$$\square - 3 = \square$$

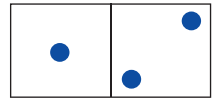

$$\underline{1 + 2 = \square}$$

$$3 - \square = \square$$

$$3 - 2 = \square$$



3.

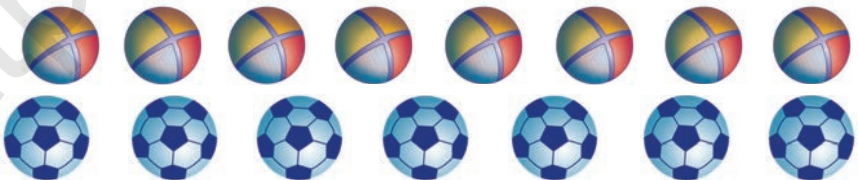

... нешеу артық?

... нешеу кем?



4.



$$7 + 2 = \square$$

$$9 - 7 = \square$$

$$9 - 2 = \square$$



1.

Азайғыш							
Азайтқыш	6	5	8	4	5	3	0
Айырма	4	4	2	4	2	3	5

2.  $\square - 4 = 5$        $\square - 3 = 4$        $\square - 5 = 3$   
 $\square - 6 = 2$        $\square - 6 = 3$        $\square - 5 = 4$   
 $\square - 4 = 3$        $\square - 4 = 4$        $\square - 1 = 5$

3. Сурет және қысқа жазу негізінде есеп құрастыр және оны шеш:

Бар еді – ? дана

Алынды – 2 дана

Қалды – 4 дана



4.

5.  $7 + 2$        $8 - 4$        $9 - 3$        $9 + 1$   
 $2 + 5$        $9 - 5$        $6 + 4$        $7 + 3$   
 $9 - 9$        $0 + 5$        $7 - 0$        $8 + 0$





1.

Азайғыш	6	10	8	9	7	6	8
Азайтқыш							
Айырма	4	4	2	4	2	3	5



2. Сурет негізінде есеп құрастыр және оны шеш:

Бар еді – 8 дана

Жейілді – ? дана

Қалды – 6 дана



3.

$8 - \square = 3$

$10 - \square = 2$

$6 - \square = 4$

$9 - \square = 5$

$7 - \square = 5$

$4 - \square = 3$



4.

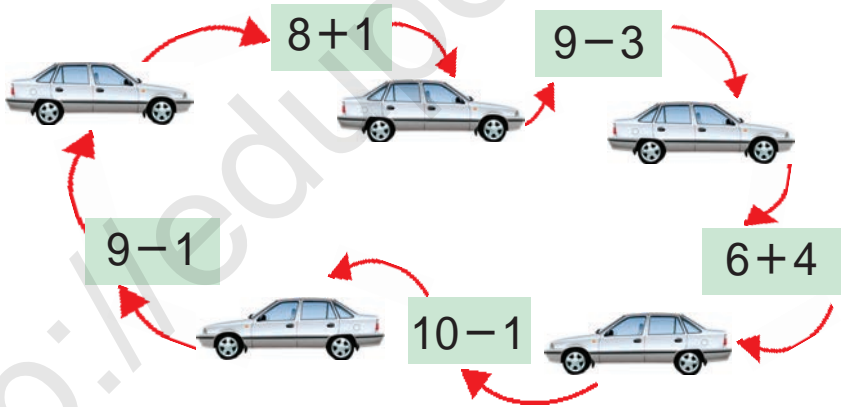

5.

Салыстыр:

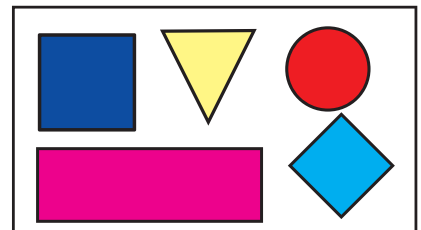
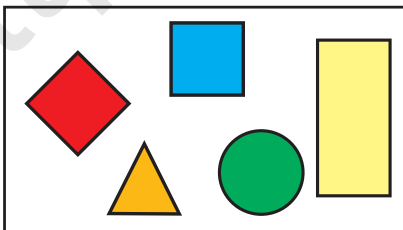

6.

$10 - 2$

$9 - 5$

$6 + 4$

$8 + 2$

$10 - 1$

$7 - 3$

$6 - 2$

$8 - 3$





1. Есеп құрастыр және оны шеш:



1	0	-	2	=	8
---	---	---	---	---	---

8	+	2	=	1	0
---	---	---	---	---	---

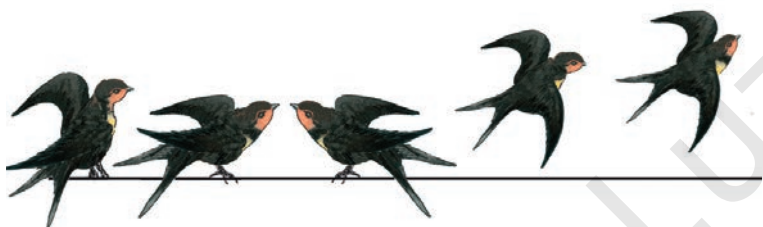

$5 - 2 = 3$       5 пен 2-нің айырмасы 3-ке тең

$3 + 2 = 5$       3 пен 2-нің қосындысы 5-ке тең



2.  $8 - 3 = 5$

$9 - 5 = 4$

$7 - 3 = 4$

$5 + 3 = \square$

$4 + 5 = \square$

$4 + 3 = \square$

3.



5	+		=	
---	---	--	---	--

9	-		=	
---	---	--	---	--



4. Есепте!

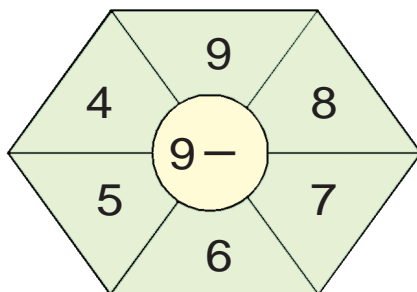
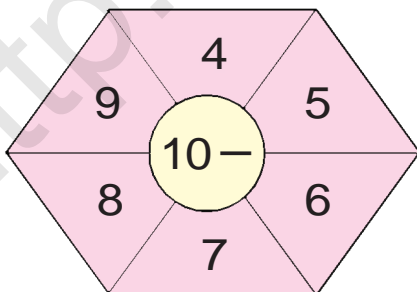

5. Есептерді шеш:

$8 - 8$

$9 - 2$

$8 - 6$

$6 + 3$

$8 + 2$

$3 + 1$

$5 - 3$

$5 - 5$





# Қосу мен айыру амалдары арасындағы байланыс

1.

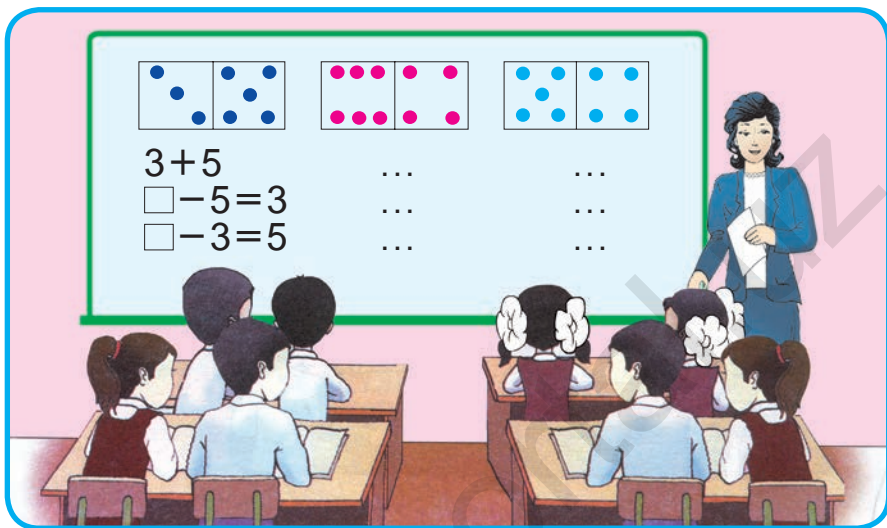

2.  $6+2$                        $9-2$                        $3+4$                        $7-2$   
 $8-6$                                $2+7$                        $7-3$                        $2+5$

3. Ойлап тап!

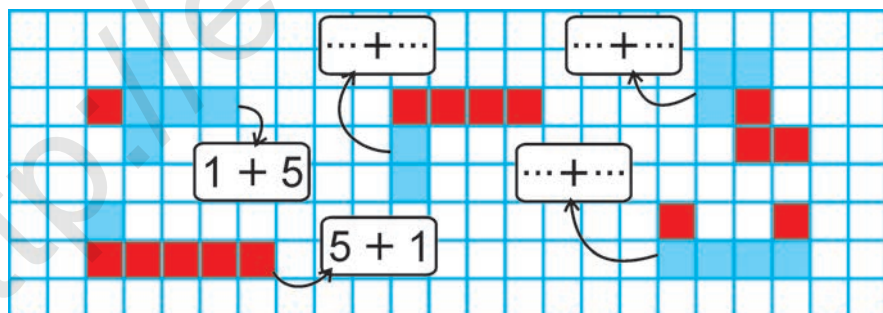

4. Кәрімде 7 дана, Сабырда одан 3 көп қаламсап бар. Сабырда қанша қаламсап бар?

Кәрімде – 7 дана қаламсап  
 Сабырда – ?, 3 дана артық

# Қосудың орын алмастыру қасиеті

$2 + 1 = 3$



$1 + 2 = 3$

1.

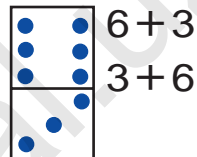
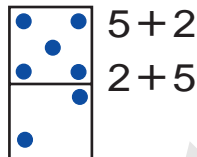
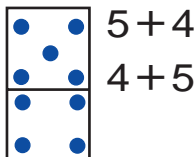

2.

Сурет негізінде мәселе құрастыр:



3	+	2	=	
---	---	---	---	--

2	+	3	=	
---	---	---	---	--

3.

$8 + 2 = \square \square$

$8 + \square = 9$

$7 + 2 = \square$

$2 + 8 = \square \square$

$\square + 8 = 9$

$2 + 7 = \square$

4.

«Балықшалар» ойыны

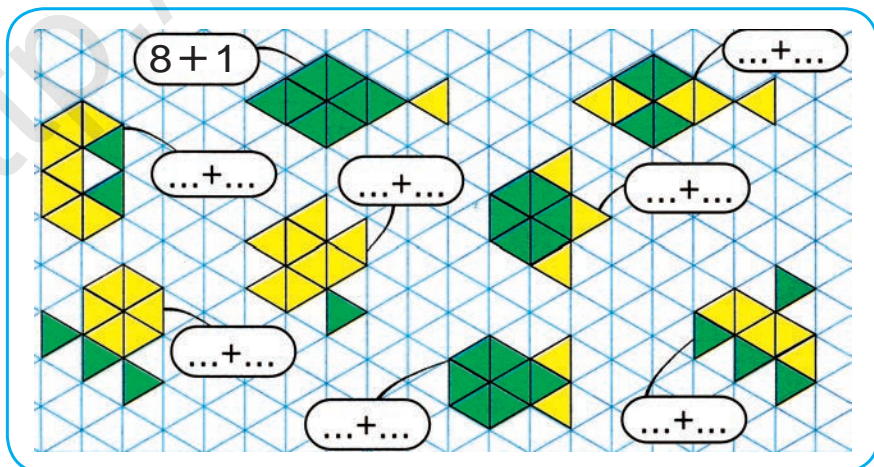

# Өтілгендерді қайталау

1. Есеп құрастыр және оны шеш:



$$3 + \square = 7$$

$$7 - 3 = \square$$

2.  $7 + \square = 10$

$\square + 2 = 10$

$5 + \square = 7$

$3 + \square = 9$

$\square + 6 = 9$

$4 + \square = 6$

3. Санап тап!



4.  $9 - 9$        $6 + 3$        $8 - 4$        $4 + 3$   
 $9 - 7$        $7 - 1$        $5 + 4$        $7 - 5$

5. Амал белгілерін торкөз ішіне теңдіктер дұрыс болатындай етіп қой:

$5 \square 2 = 7$

$3 \square 5 = 8$

$3 \square 4 = 7$

$6 \square 1 = 5$

$4 \square 3 = 7$

$2 \square 5 = 7$

$9 \square 3 = 6$

$9 \square 4 = 5$

$4 \square 4 = 8$

# 11-ден 100-ге дейінгі болған сандар. Фигуралар

## 11-ден 20-ға дейінгі болған сандар

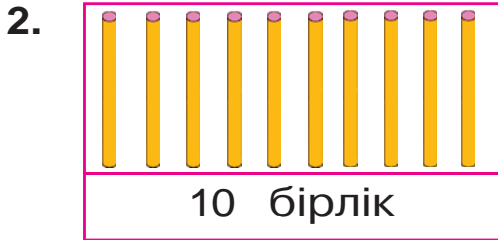
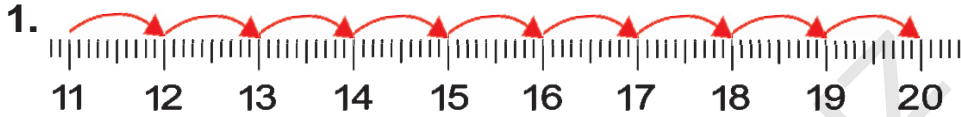

3. Кестеде қандай сандар бейнеленген?

Ондықтар	Бірліктер	Ондықтар	Бірліктер
<input type="text" value="1"/>	<input type="text" value="2"/>	<input type="text" value="2"/>	<input type="text" value="0"/>

4. 12, 14, 16, 18, 20 сандарының әрбір цифры нені білдіреді?

5. Бос торкөздерді толтыр:

10	12	14	16	18	20
----	----	----	----	----	----

6. 1 ондық және 8 бірліктен, 1 ондық және 3 бірліктен құралған санды жаз.

7. Салыстыр:

11  12 | 13  12 | 15  15 | 18  17



11

12

13

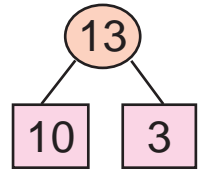
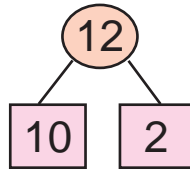
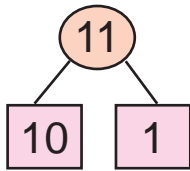

1.  $9+1=10$   
 $8+2$   
 $7+3$   
 $6+4$   
 $5+5$

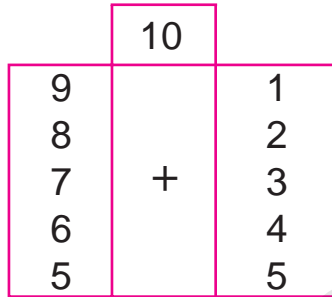

- $8+1+1$   
 $7+1+2$   
 $6+1+3$   
 $5+1+4$   
 $4+1+5$

2.

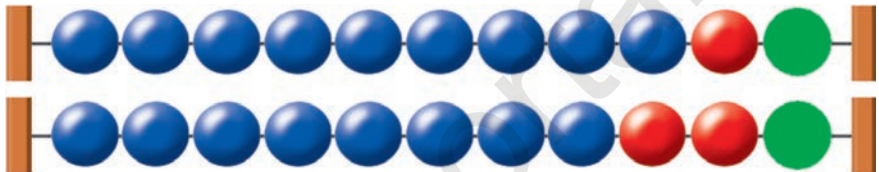

3.



		+		=	1	2
--	--	---	--	---	---	---



4.  $9+1+1$        $5+5+2$        $7+3+1$   
 $8+2+1$        $4+6+1$        $6+4+2$

5. Жағалауда 13 үйрек жүрген еді. Олардың 3-еуі суға түсіп, жүзіп кетті. Жағалауда неше үйрек қалды?

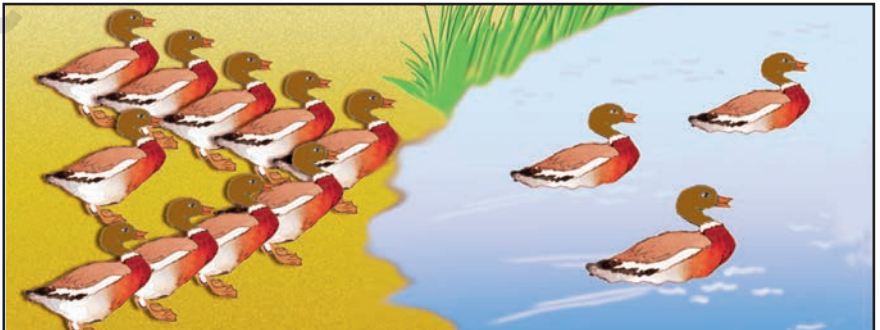



14

15

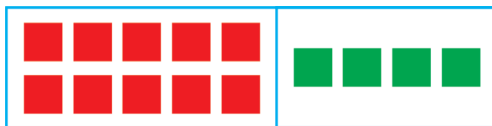

$10 + 4 = \square \square$

$14 - 4 = \square \square$

$14 - 10 = \square$

1.

2. Екі аквариумда 14 балық бар. Егер олардың бірінде 10 балық болса, екінші аквариумда неше балық бар?

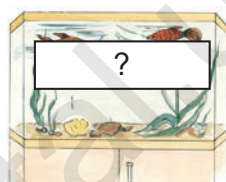

14 дана

3.



$10 + 5 = \square \square$

$15 - 5 = \square \square$

$15 - 10 = \square$

4. Есеп құрастыр және оны шеш:

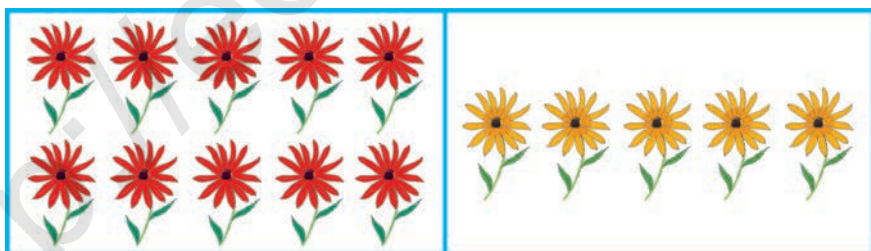

$\square + 5 = \square$

5. Таңертең дүкенде 15 шкаф бар еді. Кешке дейін 5 шкаф сатылды. Дүкенде неше шкаф қалды?

6.  $10 + 5$

$14 + 1$

$12 + 1$

$10 + 3$

$15 - 5$

$15 - 1$

$14 - 1$

$13 - 3$

16

17

18

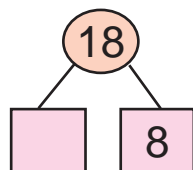
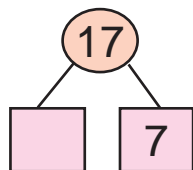
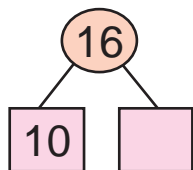

1.  $10 + 6$      $10 + 7$   
 $15 + 1$      $16 + 1$   
 $16 - 1$      $17 - 1$



16 - 6

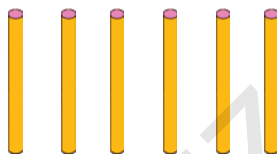

16 - 10

2. 11, 13, 15, 16, 17 сандарының әр бірінде неше ондық және неше бірлік бар?

3.



18



8 кем

?

1	8	-	8	=		
---	---	---	---	---	--	--

1	8	-	1	0	=	
---	---	---	---	---	---	--

4.  $10 + 5 \square 18$      $16 - 1 \square 17$      $15 + 1 \square 18$   
 $14 - 4 \square 10$      $10 + 8 \square 15$      $17 - 1 \square 16$

5. Кітап 18 беттен тұрады. Сәлім кітаптың 8 бетін оқып болды. Ол және неше бетті оқу керек?

?

$10 + \bigcirc = 18$

$17 - \bigcirc = 16$

$\bigcirc - 8 = 10$

$\bigcirc + 1 = 18$

$10 + \bigcirc = 15$

$15 - \bigcirc = 10$

19

20

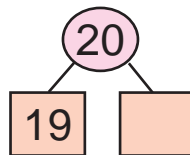
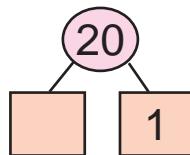
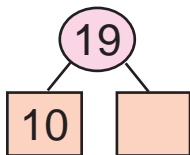

1.



$$10 + 9 = 19$$

$$19 - 9 = 10$$

2. Таңертең дүкенде 20 теледидар бар еді. Кешке шейін 10 теледидар сатылды. Неше теледидар қалды?

3.

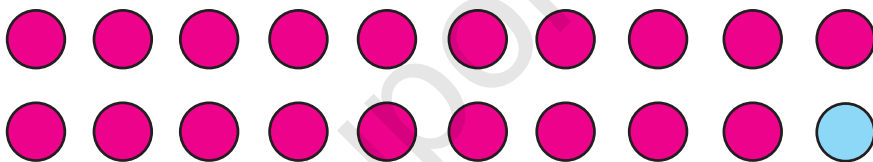

$$19 + 1 = 20$$

$$20 - 1 = 19$$

4.  $10 + 8$        $17 - 1$        $10 + 5$        $16 - 6$   
 $18 - 8$        $17 + 1$        $15 - 5$        $10 + 6$

5.

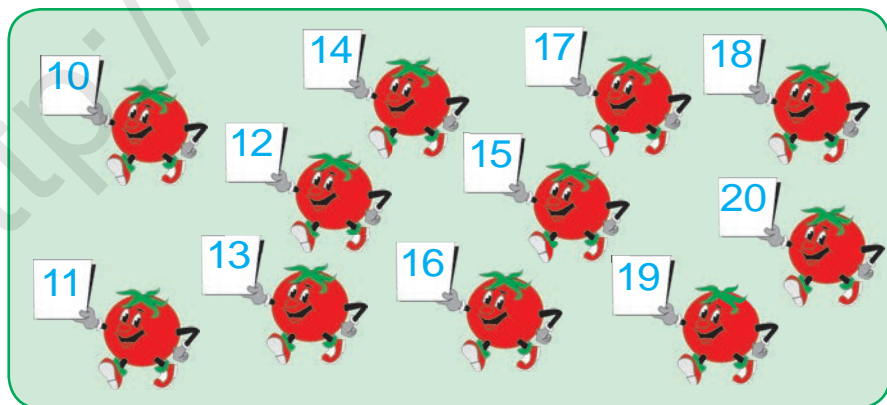

6.  $20 - 1 \square 19$        $10 + 5 \square 16$        $18 - 8 \square 14$   
 $19 + 1 \square 18$        $15 - 5 \square 10$        $13 + 1 \square 12$



# Жақшалар



1.  $15 + 3 = \square \square$

$15 - 3 = \square \square$

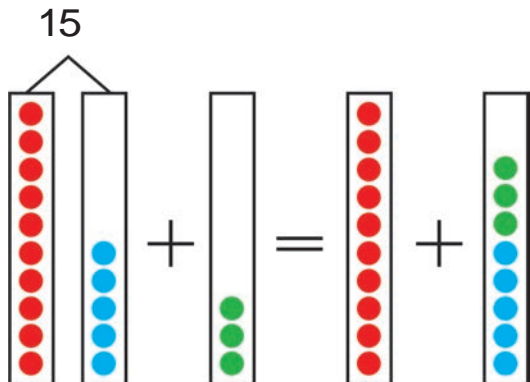

$$15 + 3 = (10 + 5) + 3 = 10 + (5 + 3) = 10 + 8 = 18$$

$$15 - 3 = (10 + 5) - 3 = 10 + (5 - 3) = 10 + 2 = 12$$

**Егер санға қосынды немесе айырманы қосу керек болса, олар жақшаның ішіне жазылады. Жақшаның ішінде берілген өрнек бірінші орындалады:**

$$10 + (5 + 3)$$

$$10 + (5 - 3)$$



2. Оқы және есепте:

1) 9 санына 7 мен 3 сандарының қосындысын қос:  $9 + (7 + 3)$

2) 6 саны мен 4 санының қосындысынан 5 санын азайт:  $(6 + 4) - 5$

3. Түсіндіріп шеш:

$$(8 + 2) - 6$$

$$6 + (6 + 4)$$

$$(5 + 5) - 3$$

$$(7 + 3) - 4$$

$$3 + (9 - 2)$$

$$(9 + 1) - 4$$





$$4. \quad \begin{array}{l} 5 + (7 + 3) \\ 6 + (9 - 5) \\ 7 + (8 + 2) \end{array}$$

$$\begin{array}{l} (7 + 3) - 3 \\ (8 - 3) + 4 \\ (9 + 1) - 2 \end{array}$$

$$\begin{array}{l} (5 + 5) - 5 \\ (9 - 2) + 3 \\ (4 + 6) + 8 \end{array}$$

5. Кітап шкафының бірінші қатарына 10 дана, екінші қатарына одан 8 дана артық кітап терілді. Шкафтың екінші қатарына неше кітап терілген?



6. Сурет негізінде есеп құрастыр және оны шеш:



7. Теректің биіктігі 13 м. Шегіршіннің биіктігі одан 3 м кем. Шегіршіннің биіктігін табыңдар.



8. Үлгі бойынша орында:  $12 = 10 + 2$

$15 = 10 + \square$

$19 = 10 + \square$

$14 = 10 + \square$

$17 = 10 + \square$

$16 = 10 + \square$

$18 = 10 + \square$

$13 = 10 + \square$

$20 = 15 + \square$

$11 = 10 + \square$



# Сандарды ондық арқылы өтіп қосу

1. 10 санын құрастыру үшін бос тор-көздерге қайсы сандарды қою керек?

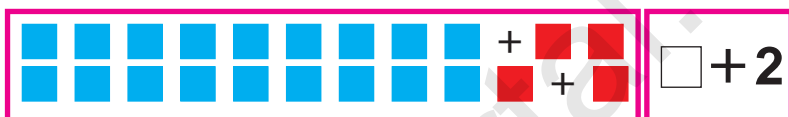
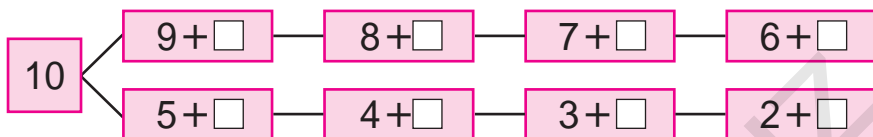

$$9 + 2 = \square\square$$

9-ға 2-ні қосу үшін 2 саны бөлініп қосылады. Бұл төмендегідей орындалады:

а) Алдымен 10 санын құрастыру үшін қанша керек болса, сонша қосылады:

$$9 + 1 = 10$$

б) 2 – бұл 1 + 1 екендігі белгілі. 9-ға 1 қосылады, 10 құрастырылды. 10-ға және 1-ді қосу керек. Демек, 10 + 1 = 11 болады.

$$9 + 2 = 11$$



$$9 + 2 = \square\square$$



$$\underline{9} + 1 + 1 = 11$$

2. Ділшаттың 9 дана жаңғағы бар еді. Ағасы оған және 2 жаңғақ берді. Ділшатта неше жаңғақ болды?

3.  $14 + 1 = \square\square$  |  $18 - 10 = \square$  |  $10 + 5 = \square\square$   
 $15 - 1 = \square\square$  |  $16 - 10 = \square$  |  $10 + 3 = \square\square$





4. Қысқа жазу негізінде есеп құрастыр оны шеш:

Ертек кітаптар – 9 дана  
Өлең кітаптар – 2 дана ) ? дана



5.  $17 - 10$  |  $10 + 3$  |  $20 - 1$  |  $10 + 9$   
 $10 + 10$  |  $18 - 8$  |  $10 + 5$  |  $14 - 4$   
 $18 - 10$  |  $10 + 6$  |  $15 - 5$  |  $10 + 2$



1.

+

+ 3

$9 + 3 = \square\square$   
 $\begin{array}{c} \diagdown \quad \diagup \\ 1 \quad 2 \end{array}$   
 $9 + 1 + 2 = 12$

$8 + 3 = \square\square$   
 $\begin{array}{c} \diagdown \quad \diagup \\ 2 \quad 1 \end{array}$   
 $8 + 2 + 1 = 11$

+

**Есіңде сақта:**

$9 + 2 = 11$

$9 + 3 = 12$

$8 + 3 = 11$



2.  $8 + 3 \square 11$        $9 + 2 \square 12$        $9 + 3 \square 11$



3. Наргизаның анасы 8 дана торкөз, 3 дана бір сызық дәптер әкелді. Наргизаның анасы барлығы болып қанша дәптер әкелген?

4. Қандай геометриялық фигураларды көріп тұрсың? Аттарын ата.

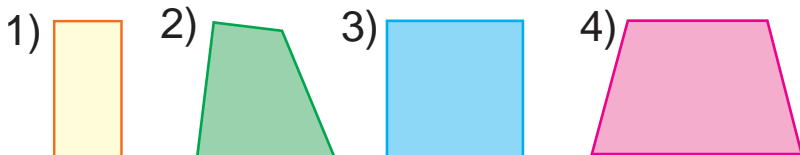

5.  $8+2$   
 $9+2$

$8+3$   
 $9+3$

$3+9$   
 $3+8$

$2+9$   
 $2+8$

1.

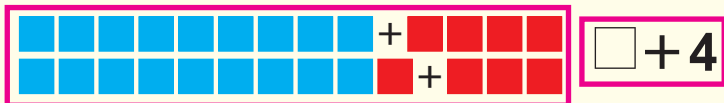

4	
3	
2	
1	

$9+4 = \square\square$

$9+1+3 = 13$

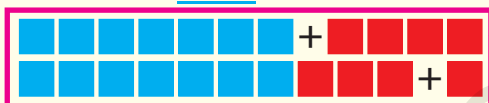

$7+4 = \square\square$

$7+3+1 = 11$

**Есіңде сақта:**

$9+4 = 13$

$8+4 = 12$

$7+4 = 11$

2. Сырлаушы бірінші күні 7 есікті, екінші күні одан 4 дана артық есікті бояды. Сырлаушы екінші күні қанша есікті бояған?

3. Сурет негізінде есеп құрастыр және оны шеш:



? дана



? дана

4. Мысалдардың шешімін түсіндір:

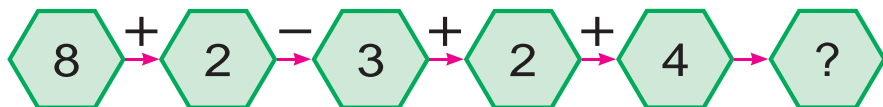

5.  $8+4 \square 12$

$7+4 \square 12$

$9+4 \square 11$

$9+3 \square 11$

$8+3 \square 12$

$8+2 \square 13$



1.

5	
1	
2	
3	
4	

$\square + 5$

$9 + 5 = \square\square$

$\begin{array}{c} 1 \quad 4 \\ \diagdown \quad \diagup \\ 9 + 1 + 4 = 14 \end{array}$

$8 + 5 = \square\square$

$8 + 2 + 3 = 13$

**Есіңде сақта:**

$9 + 5 = 14 \quad | \quad 8 + 5 = 13 \quad | \quad 7 + 5 = 12 \quad | \quad 6 + 5 = 11$



2. Әкбар 9 ақ, 5 күлрең қоянға қамқорлық жасады. Әкбар барлығы болып қанша қоянға қамқорлық жасады?

3. Сурет негізінде есеп құрастыр және оны шеш:



$\square + \square = \square\square$



4. Үлгі бойынша орында:  $11 = 9 + 2$ .

$11 = 6 + \square$

$13 = 9 + \square$

$11 = 7 + \square$

$11 = 8 + \square$

$12 = 8 + \square$

$14 = 9 + \square$

$12 = 7 + \square$

$13 = 8 + \square$

$12 = 9 + \square$

5.  $6 + 4$

$9 + 4$

$8 + 4$

$7 + 4$

$8 + 3$

$7 + 3$

$9 + 3$

$9 + 2$





1.

6	
5	
	4
3	
	2

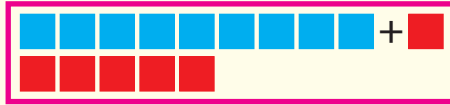

$$\square + 6$$

$$9 + 6 = \square \square$$

$$\begin{array}{c} \swarrow \quad \searrow \\ 1 \quad 5 \end{array}$$

$$9 + 1 + 5 = 15$$

**Есіңде сақта:**

$$9 + 6 = 15 \quad | \quad 8 + 6 = 14 \quad | \quad 7 + 6 = 13 \quad | \quad 6 + 6 = 12$$



2. Спорт үйірмелеріне 9 футбол және 6 баскетбол добы сатып алынды. Үйірмелер үшін барлығы болып қанша доп сатып алынған?



3. Мысалдардың шешімін түсіндір:

$$7 + \square$$

$$9 + \square$$

12

$$8 + \square$$

$$6 + \square$$

$$7 + \square$$

$$9 + \square$$

13

$$8 + \square$$

$$6 + \square$$

4. Бос торкөздерге теңдіктер дұрыс болатындай етіп сандарды қой.

$$9 + \square = 11$$

$$8 + \square = 13$$

$$8 + \square = 14$$

$$8 + \square = 12$$

$$9 + \square = 12$$

$$9 + \square = 15$$



5. Қысқа жазу негізінде есеп құрастыр және оны шеш:

Бар еді – 8 дана  
 Қосылды – 6 дана ) ?-дана



$$6. \quad 8 + 4$$

$$9 + 5$$

$$7 + 5$$

$$6 + 4$$

$$8 + 5$$

$$9 + 2$$

$$7 + 4$$

$$6 + 5$$



1.

7	
6	
	5
4	
	3

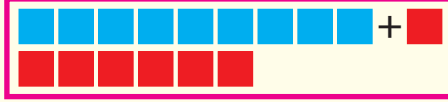

$$\square + 7$$

$$9 + 7 = \square \square$$

1    6

$$9 + 1 + 6 = 16$$

**Есіңде сақта:**

$9 + 7 = 16$

$8 + 7 = 15$

$7 + 7 = 14$



2. Үлгі бойынша орында:  $13 = 7 + 6$ .

$14 = 9 + \square$

$15 = 9 + \square$

$16 = 9 + \square$

$15 = 8 + \square$

$14 = 8 + \square$

$12 = 8 + \square$



3. Сынып кітапханасы үшін 9 әңгіме, 7 ертеке кітабы сатып алынды. Сынып кітапханасы үшін барлығы қанша кітап сатып алынған?



4. Мысалдардың шешімін түсіндір:

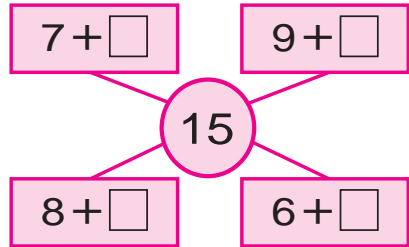
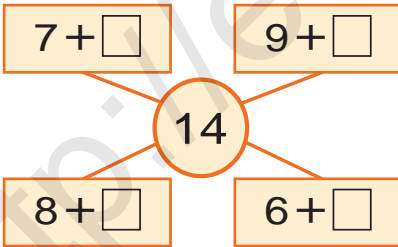

5. Фигураларды дәптеріңе сыз және олардың аттарын жаз:

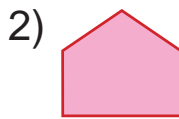

6.  $9 + 5$   
 $8 + 6$

$9 + 6$   
 $8 + 7$

$9 + 7$   
 $8 + 4$

$7 + 7$   
 $6 + 6$



1.

8	
7	
	6
5	
	4

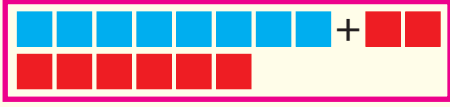

$$\square + 8$$

$$8 + 8 = \square \square$$

$$\begin{array}{c} \swarrow \quad \searrow \\ 2 \quad 6 \end{array}$$

$$8 + 2 + 6 = 16$$

9	
8	
	7
6	
	5

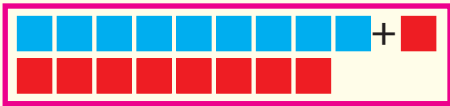

$$\square + 9$$

$$9 + 9 = \square \square$$

$$\begin{array}{c} \swarrow \quad \searrow \\ 1 \quad 8 \end{array}$$

$$9 + 1 + 8 = 18$$

**Есіңде сақта:**

$8 + 8 = 16$

$9 + 8 = 17$

$9 + 9 = 18$



2.

$8 + 7 \square 16$

$9 + 8 \square 17$

$9 + 7 \square 14$

$9 + 9 \square 17$

$8 + 7 \square 15$

$7 + 7 \square 16$



3.

Бір аптада бірінші шебер 9 сандық, екіншісі болса 8 сандық жасады. Екі шебер бірге қанша сандық жасаған?

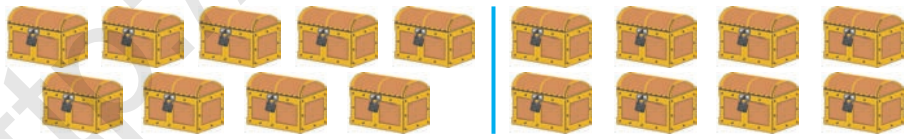

4.

Әрбір фигурада нешеуден шырпы жұмсалған?

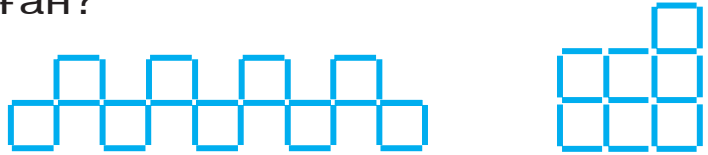

5.

$9 + 6$

$8 + 6$

$9 + 4$

$7 + 7$

$9 + 5$

$9 + 7$

$8 + 5$

$8 + 4$





# Сандарды ондық арқылы өтіп азайту



1.



$$11 - \square$$

11-ден 6 санын азайту үшін 6 саны бөлініп азайтылады. Бұл төмендегідей орындалады:

**Бірінші тәсіл.** 1) Алдымен 10 пайда болу үшін 11-ден 1 санын айыру керек:

$$11 - 1 = 10$$

2) 6 – бұл 1 + 5 екендігі белгілі. 11-ден 1 айырылды, тағы 5-ті айыру керек.

Демек,  $10 - 5 = 5$

Мұны былай жазу мүмкін:

$$11 - 6 = 5$$



немесе  $11 - 6 = 5$

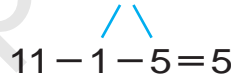

**Екінші тәсіл.** 11-бұл 6 + 5-тен құралғаны үшін мысалды былай шешу мүмкін:

$$11 - 6 = 5$$

$$11 - 5 = 6$$

Қысқаша былай жазылады:

$$11 - 6 = 5$$



$$11 - 5 = 6$$



2. Азық-түлік дүкеніне 16 қорап кәмпит және печенье келтірілді. Кәмпиттер 6 қорап болса, неше қорап печенье келтірілген?



3. Теңдіктер дұрыс болатындай сан қой:

$$9 + \square = 11$$

$$11 - \square = 5$$

$$8 + \square = 15$$

$$7 + \square = 11$$

$$11 - \square = 6$$

$$9 + \square = 14$$

4. Қысқа жазу бойынша есеп құрастыр және оны шеш:

1-тәрелкеде – 11 дана  
 2-тәрелкеде – ?, 6 дана кем



Шешуі:  $11 - 6 = \square$  дана алма.

Жауабы: екінші тәрелкеде  $\square$  да-  
 на алма бар.

5.  $9 + 8$        $11 - 5$        $10 + 3$        $9 + 6$   
 $8 + 8$        $11 - 6$        $13 - 3$        $7 + 7$

1.

$11 - 3 = \square$

$11 - 1 - 2 = 8$        $11 = 3 + 8$        $11 - 8 = 3$

$11 - 3 = 8$

**Есіңде сақта:**

$11 - 2 = 9$  |  $11 - 3 = 8$  |  $11 - 4 = 7$  |  $11 - 5 = 6$   
 $11 - 6 = 5$  |  $11 - 7 = 4$  |  $11 - 8 = 3$  |  $11 - 9 = 2$

2. Жайылымда 11 қой жайылып жүрген еді. 4 қой ажыратып қораға алып келінді. Жайылымда қанша қой қалды?

3. Әрбір фигураның нешеуден қабырғасы бар?

1)



2)

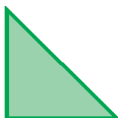

3)

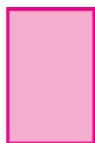

4)



4. Бір аптада бірінші қолөнерші 10, екіншісі болса 9 бесік артық жасады. Екінші қолөнерші бір аптада неше бесік жасаған?



$$5. \quad 8+6 \square 13$$

$$7+7 \square 15$$

$$7+6 \square 14$$

$$9+7 \square 16$$

$$6+5 \square 11$$

$$8+8 \square 14$$



1.

$$12-3 = \square$$

$$12-2-1=9$$

$$12-3=9$$

$12 - \square$

$$12-9=3$$

**Есіңде сақта:**

$$12-3=9 \quad | \quad 12-4=8 \quad | \quad 12-5=7 \quad | \quad 12-6=6$$

$$12-7=5 \quad | \quad 12-8=4 \quad | \quad 12-9=3$$



2. Шешудің түрлі тәсілдерін түсіндір:

$$12-4=8$$

$$\begin{array}{c} \diagdown \quad \diagup \\ 2 \quad 2 \end{array}$$

$$12-5=7$$

$$\begin{array}{c} \diagdown \quad \diagup \\ 2 \quad 3 \end{array}$$

$$12-5=7$$

$$\begin{array}{c} \diagdown \quad \diagup \\ 5 \quad 7 \end{array}$$

3. Аэропортта бірнеше ұшақ бар еді. 4 ұшақ ұшып кеткеннен соң, аэропортта 7 ұшақ қалды. Аэропортта алдын неше ұшақ болған?



4. Әрбір фигураның атын ата.

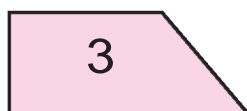
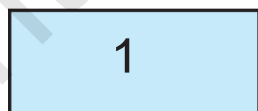

$$5. \quad 12-4 \square 8$$

$$11-5 \square 6$$

$$12-8 \square 5$$

$$12-5 \square 9$$

$$10+2 \square 7$$

$$10+7 \square 4$$

$$11-8 \square 12$$

$$12-6 \square 11$$

$$12-9 \square 11$$

1.

**Есіңде сақта:**

$13 - 4 = 9$	$13 - 5 = 8$	$13 - 6 = 7$
$13 - 7 = 6$	$13 - 8 = 5$	$13 - 9 = 4$



2. Гүлзарда 13 ақ және қызыл қалампыргүлдер гүлдеген еді. Қызыл қалампыргүлдер 7-еу болса, ақ қалампыргүлдер нешеу?



3. Теңдіктер дұрыс болатындай етіп сан қойыңдар:

$13 - \square = 7$

$8 + \square = 15$

$11 - \square = 5$

$12 - \square = 9$

$7 + \square = 13$

$12 - \square = 4$



4. Қысқа жазу бойынша есеп құрастыр және оны шеш:

Теледидар – 13 дана ←

Компьютер – ?, дана кем —

5. Фигураларды салыстыр. Әрбірінде нешеуден үшбұрыш бар?

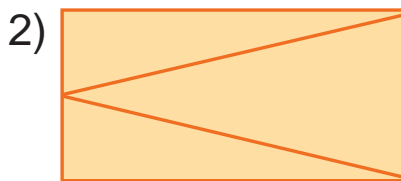
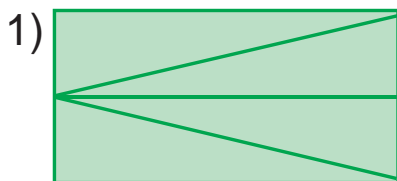

$6. 12 - (5 + 4)$

$13 - (7 + 2)$

$9 + (4 + 5)$

$8 + (6 + 4)$

$13 - (8 + 4)$

$12 - (6 + 6)$

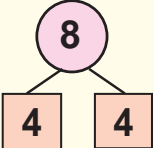
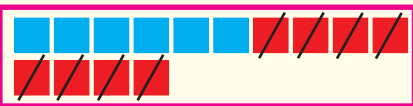
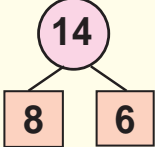

1.

 $14 - 8 = \square$ $14 - 4 - 4 = 6$	 $14 = 8 + 6$ $14 - 8 = 6$	<div style="border: 1px solid black; padding: 5px; display: inline-block;"> <math>14 - \square</math> </div>  $14 - 6 = 8$
--	--	---

### Есіңде сақта:

$14 - 9 = 5$  |  $14 - 8 = 6$  |  $14 - 7 = 7$  |  $14 - 6 = 8$  |  $14 - 5 = 9$



- |            |          |         |          |
|------------|----------|---------|----------|
| 2. $7 + 6$ | 13 - 9   | 9 + 5   | 13 - 8   |
| $8 + 8$    | $14 - 5$ | $8 + 6$ | $14 - 7$ |



3. Таңертең дүкенде 14 теледидар бар еді. Кешке дейін 8 теледидар сатылды. Дүкенде қанша теледидар қалды?



4. Мысалдардың шешімін түсіндір:

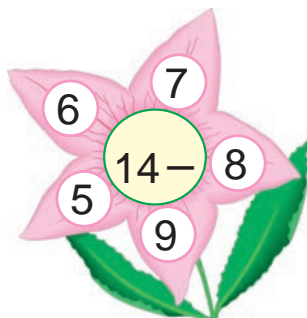
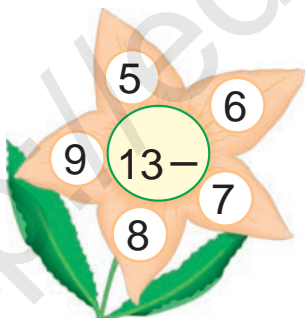

5. Мектеп алаңында 14 оқушы ойнап жүрген еді. Олардан 6-сы ұл бала болса, нешеуі қыздар болады?

- |                   |                |                |
|-------------------|----------------|----------------|
| 6. $(14 - 6) + 8$ | $14 - (5 + 9)$ | $(14 - 9) + 5$ |
| $(14 - 8) + 8$    | $13 - (9 + 4)$ | $(14 - 8) + 4$ |





1.

6

5

1

$15 - 6 = \square$

$15 - 5 - 1 = 9$

$15 - \square$

15

6

9

$15 - 6 = 9$

**Есіңде сақта:**

$15 - 6 = 9$  |  $15 - 7 = 8$  |  $15 - 8 = 7$  |  $15 - 9 = 6$



2.  $8 + 7$                        $14 - 8$                        $7 + 7$                        $14 - 5$   
 $9 + 3$                            $13 - 9$                        $9 + 5$                        $14 - 7$

3. Нафиса 15 жаста. Сіңлісі болса одан 6 жас кіші. Сіңлісі неше жаста?



4.  $14 - 8 \square 8$                        $13 - 8 \square 5$                        $9 + 6 \square 15$   
 $13 - 9 \square 8$                            $14 - 9 \square 5$                        $8 + 5 \square 12$



5. Қысқа жазу бойынша есеп құрастырып оны шеш:

Ақ кептерлер – 15 дана ←  
 Күлрең кептерлер – ?, 8 дана кем



6. Әрбір фигурада нешеуден үшбұрыш бар?

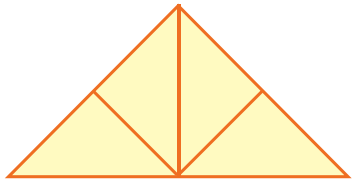
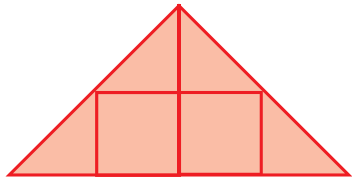

7.  $13 - (3 + 0)$                       |                       $(9 + 3) - 2$                       |                       $(8 + 7) + 5$   
 $14 - (3 + 1)$                       |                       $(8 + 6) - 4$                       |                       $(9 + 8) - 7$





1.

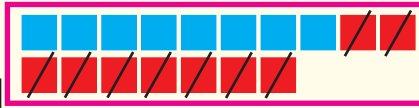
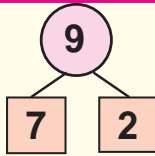

$16 - \square$

$17 - \square$

$18 - \square$

$17 - 9 = \square$

$17 = 9 + 8$

$17 - 9 = 8$

$17 - 8 = 9$

$17 - 7 - 2 = 8$

**Есіңде сақта:**

$17 - 8 = 9$

$17 - 9 = 8$

$18 - 9 = 9$

$16 - 7 = 9$

$16 - 8 = 8$

$16 - 9 = 7$



2.  $16 - 6 + 1$

$14 - 4 - 5$

$13 - 3 + 2$

$15 - 5 + 3$

$13 - 3 - 6$

$12 - 2 - 3$

3. Жұмысшылар 18 бөлмені жөндеу керек еді. Сол бөлмелердің бірнешеуін жөндегеннен кейін және 9 бөлме қалды. Жұмысшылар неше бөлмені жөндеген?



4. Кестеден жауабы бірдей болған мысалдарды тап:

$9 + 7$	$17 - 9$	$9 + 5$	$15 - 9$
$16 - 8$	$11 - 5$	$18 - 9$	$7 + 7$
$8 + 6$	$15 - 6$	$7 + 9$	$17 - 8$



5. Есеп құрастыр және оны шеш.

Бар еді – 16 жаңғақ

Жейілді – 8 жаңғақ

Қалды – ?



6.  $9 + 2$

$17 - (9 + 1)$

$(9 + 9) - 8$

$8 + 3$

$16 - (4 + 2)$

$(8 + 8) - 6$

# Қосу мен азайту кестелерінен пайдалану



1.

$\begin{array}{r} + \\ - \end{array}$	1	2	3	4	5	6	7	8	9	10
1	0									
2	1									
3	2	1								
4	3	2	1							
5	4	3	2	1						
6	5	4	3	2	1					
7	6	5	4	3	2	1				
8	7	6	5	4	3	2	1			
9	8	7	6	5	4	3	2	1		
10	9	8	7	6	5	4	3	2	1	

Үлгі:

$$3 - 1 = 2$$

$$5 + 2 = 7$$



2. Автосарайда 18 автокөлік тұрды. Олардың 9-ы жүк машинасы, қалғандары болса жеңіл автокөлік. Автосарайда қанша жеңіл машина бар?



$$3. \quad \begin{array}{lll} 8 + 7 \square 15 & 12 - 6 \square 14 & 13 - 5 \square 9 \\ 9 + 5 \square 16 & 16 - 8 \square 13 & 13 - 6 \square 7 \end{array}$$



4. Мысалдардың жауабын өсу тәртібінде орналастыр:



$$5. \quad \begin{array}{lll} (15 - 5) + 9 & | & 12 - (9 + 2) & | & (14 - 4) + 2 \\ (10 + 7) - 7 & | & 15 - (5 + 3) & | & (12 - 2) + 3 \\ (10 + 8) - 8 & | & 15 - (4 + 3) & | & (10 + 5) - 5 \end{array}$$



# Сандарды қосу және айыру амалдары жәрдемінде салыстыру

-  1. Бірінші кітапта 18, екінші кітапта 9 ертеке бар. Екінші кітаптағы ертекектер бірінші кітаптағыдан қанша кем? Бірінші кітаптағы ертекектер болса екінші кітаптағыдан қанша көп?

-  2.  $8+6 \square 13$                        $9+7 \square 18$                        $7+6 \square 15$   
 $7+5 \square 12$                        $8+8 \square 14$                        $9+5 \square 11$

-  3. Салыстыр:

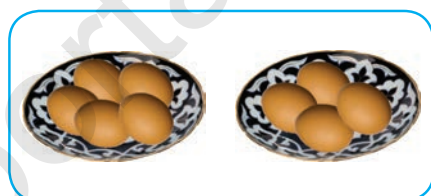
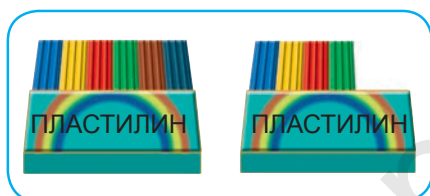

4. Сурет негізінде есеп құрастырып және оны шеш.



... қанша көп?

... қанша кем?

-  5. Ойлап тап!

$$10 + 10 - 1 - 9 = ?$$

6. Бірінші легенде 9 алмұрт, екінші легенде болса 7 сабдалы бар. Алмұрттар сабдалыдан қанша көп? Сабдалы алмұрттан қанша кем?



# Санды бірнеше бірлікке асыру және азайтыру

1. Сурет негізінде есеп құрастыр және оны шеш:

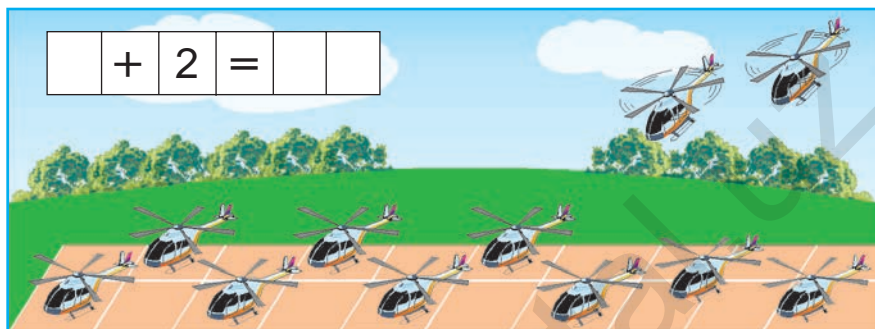

2. Бірінші пойызда 19, екінші пойызда одан 1 артық вагон бар. Екінші пойызда қанша вагон бар?

3. Мысалдардың шешімін түсіндір:

$$8 + 7 \rightarrow 15 - 8 \rightarrow 7 + 4 \rightarrow 11 - 5 \rightarrow 6 + 9$$

$$15 - 6 \rightarrow 9 + 3 \rightarrow 12 - 5 \rightarrow 7 + 7 \rightarrow 14 - 6$$

4. Есеп құрастыр және оны шеш:

$$10 - 2 = 10 - 1 - 1$$



5. Фигурадан 1 шырпыны алғанда, нәтижеде 3 квадрат қалсын.

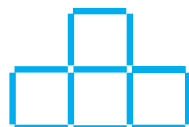

# 21-ден 100-ге дейінгі сандарды оқу және жазу. Олардың ондық құрамы

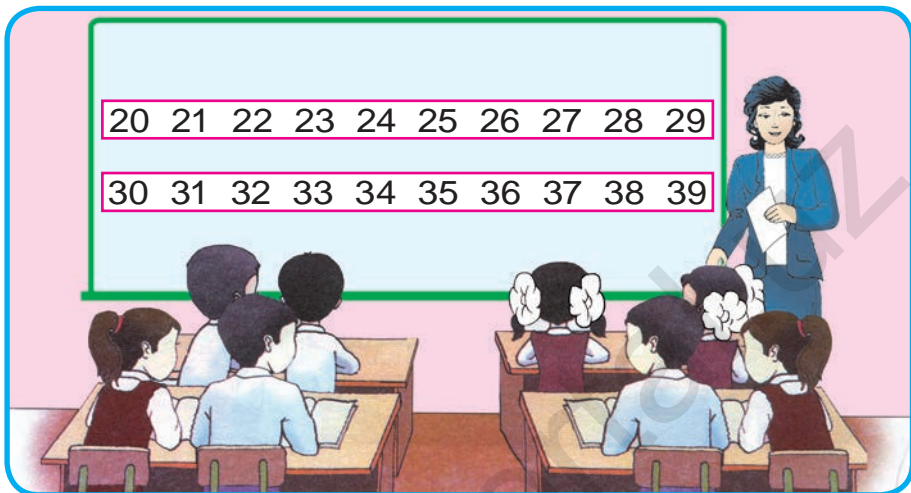

2.

Ондықтар	Бірліктер		
	1	жиырма бір	21
	2	жиырма екі	22
	3	жиырма үш	23
	4	жиырма төрт	24
2	5	жиырма бес	25
	6	жиырма алты	26
	7	жиырма жеті	27
	8	жиырма сегіз	28
	9	жиырма тоғыз	29

3. Дүкенге 25 қызыл және сары түсті доп әкелінді. Қызыл доптар 5-еу болса, сары доптар нешеу?



4. 20 санынан соң қай сан келеді?



5.

$20 + 2$	$25 - 5$	$20 + 9$	$24 - 4$
$20 + 6$	$28 - 8$	$20 + 7$	$29 - 9$



1.

Ондықтар	Бірліктер		
3	1	отыз бір	31
	2	отыз екі	32
	3	отыз үш	33
	4	отыз төрт	34
	5	отыз бес	35
	6	отыз алты	36
	7	отыз жеті	37
	8	отыз сегіз	38
	9	отыз тоғыз	39

2. 30 санынан соң қайсы сан келеді?



3 ондық және 1 бірлік. Отыз бір.

3.  $39 \square 30$  |  $30 \square 35$  |  $39 \square 39$  |  $34 \square 24$ 

4. Автобуста 36 жолаушы бар еді. Бірінші аялдамада 6 жолаушы түсіп қалды. Автобуста неше жолаушы қалды?

5.  $20 + 8$  |  $35 - 5$  |  $30 + 3$  |  $24 - 4$   
 $28 - 8$  |  $20 + 9$  |  $39 - 9$  |  $30 + 8$



1.

Ондықтар	Бірліктер		
	1	қырық бір	41
	2	қырық екі	42
	3	қырық үш	43
	4	қырық төрт	44
4	5	қырық бес	45
	6	қырық алты	46
	7	қырық жеті	47
	8	қырық сегіз	48
	9	қырық тоғыз	49

2. Насибаның анасы 40 торкөз, 9 бір сызықты дәптер әкелді. Насибаның анасы барлығы болып қанша дәптер әкелді?



3. Әрқайсы суретте нешеуден таяқша бар?

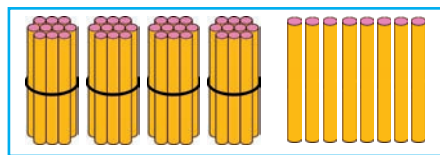
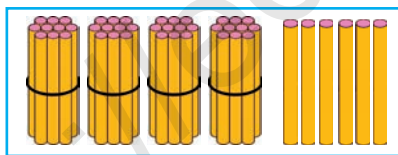

Қырық алты, қырық сегіз сандарында нешеуден бірлік барын суретке қарап айт.



4. Мысалдардың шешімін түсіндір:

$$30 + 8 - 8 + 10 + 9 = ?$$

5.

$20 + 4$	$40 + 2$	$10 + 7$	$40 + 9$
$20 + 9$	$28 - 8$	$30 + 5$	$37 - 7$







1.

Ондықтар	Бірліктер		
5	1	елу бір	51
	2	елу екі	52
	3	елу үш	53
	4	елу төрт	54
	5	елу бес	55
	6	елу алты	56
	7	елу жеті	57
	8	елу сегіз	58
	9	елу тоғыз	59



2. Әлім циркте елу сегізінші орынға отырды. Оның оң жағындағы және сол жағындағы орындардың нөмірлерін айт.

3. Сандардың қосындысын есепте: 50 және 4, 50 және 2, 50 және 5, 50 және 8.



4. Бос торкөздерді толтыр:

5	1				5	4			5	6					
5	9													5	2



5.  $50 \square 54$  |  $52 \square 42$  |  $36 \square 55$  |  $58 \square 47$



6. Автокөлік зауыты бірінші күні 50, екінші күні одан 4 дана артық машина жасап шығарды. Зауыт екінші күні қанша машина жасап шығарған?



7.  $40 + 6$  |  $58 - 8$  |  $30 + 7$  |  $24 - 4$   
 $32 - 2$  |  $20 + 5$  |  $59 - 9$  |  $40 + 2$



1.

Ондықтар	Бірліктер		
6	1	алпыс бір	61
	2	алпыс екі	62
	3	алпыс үш	63
	4	алпыс төрт	64
	5	алпыс бес	65
	6	алпыс алты	66
	7	алпыс жеті	67
	8	алпыс сегіз	68
	9	алпыс тоғыз	69

2. Сәлімнің бақшасында 69 қалампыргүл ашылды. Ол 9-ын мерекеге алып келді. Оның бақшасында неше қалампыргүл қалды?



$$\begin{array}{l|l|l}
 3. \quad 50 + \square = 59 & 47 - \square = 40 & 30 + \square = 38 \\
 61 - \square = 60 & 60 + \square = 63 & 26 - \square = 20 \\
 60 + \square = 69 & 65 - \square = 60 & 50 + \square = 54
 \end{array}$$



4. Мысалдардың жауабын тап:

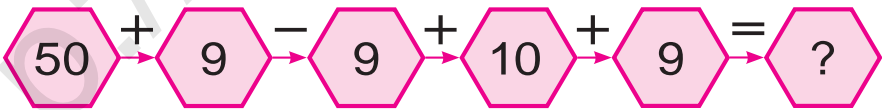

5. Мектеп асханасында 60 орындық бар еді. Тағы 6 жаңа орындық қойылды. Орындықтар нешеу болды?



6. Сандардың айырмасын тап:

26 және 6, 35 және 5, 68 және 8,  
 42 және 2, 49 және 9, 27 және 7,  
 83 және 3, 94 және 4.



1.

Ондықтар	Бірліктер		
7	1	жетпіс бір	71
	2	жетпіс екі	72
	3	жетпіс үш	73
	4	жетпіс төрт	74
	5	жетпіс бес	75
	6	жетпіс алты	76
	<b>7</b>	<b>жетпіс жеті</b>	<b>77</b>
	8	жетпіс сегіз	78
	9	жетпіс тоғыз	79

2. Афрасияб пойызының бір вагонында 78 жолаушы бар еді. Бірінші аялдамада 8 жолаушы түсті. Вагонда қанша жолаушы қалды?

3. Үлгі бойынша орында:  $38 = 30 + 8$

$$69 = \dots \qquad 58 = \dots \qquad 47 = \dots$$

$$53 = \dots \qquad 75 = \dots \qquad 24 = \dots$$

$$26 = \dots \qquad 52 = \dots \qquad 28 = \dots$$

4. 7 ондық және 5 бірліктен, 5 ондық және 4 бірліктен құралған санды жаз.

5. Бос торкөздерді толтыр:

71			74		76			
79				75			72	

6.  $70 + 3$  |  $60 + 6$  |  $77 - 7$  |  $50 + 8$   
 $73 - 3$  |  $66 - 6$  |  $70 + 7$  |  $58 - 8$



1.

Ондықтар	Бірліктер		
8	1	сексен бір	81
	2	сексен екі	82
	3	сексен үш	83
	4	сексен төрт	84
	5	сексен бес	85
	6	сексен алты	86
	7	сексен жеті	87
	8	сексен сегіз	88
	9	сексен тоғыз	89



2. Бос торкөздерді толтыр:

8 1			8 4		8 6			
8 9				8 5			8 2	



3. Даладан бір машинада 83 қап, екінші машинада біріншідегіге қарағанда 3 қап кем пияз алып кетілді. Даладан екінші машинада неше қап пияз алып кетілген?



4. Әрбір төртбұрышта нешеуден үшбұрыш бар?

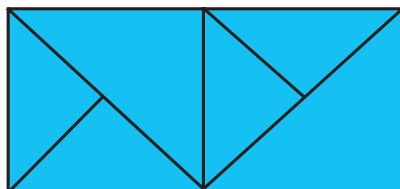
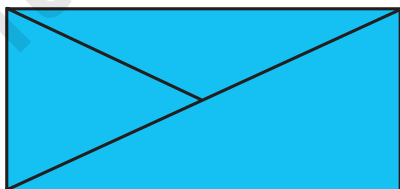

5.	$69 - 9$		$50 + 7$		$80 + 2$		$68 - 8$
	$70 + 8$		$65 - 5$		$29 - 0$		$39 + 0$





1.

Ондықтар	Бірліктер		
9	1	тоқсан бір	91
	2	тоқсан екі	92
	3	тоқсан үш	93
	4	тоқсан төрт	94
	5	тоқсан бес	95
	6	тоқсан алты	96
	7	тоқсан жеті	97
	8	тоқсан сегіз	98
	9	тоқсан тоғыз	99



2. Жылыжайда 90 түп ақ және 8 түп қызыл раушангүл бар. Жылыжайда барлығы неше түп раушангүл бар?



3. Ойлап тап!



4.  $70 + 3 \square 86$  |  $95 - 5 \square 90$  |  $80 + 2 \square 82$   
 $69 - 9 \square 94$  |  $50 + 8 \square 32$  |  $49 - 9 \square 37$



5.

Қосылғыш	90	70	90	90	80	90
Қосылғыш	1	9	3	2	5	4
Қосынды						



6.  $80 + 2$  |  $90 + 5$  |  $80 + 8$  |  $69 - 9$   
 $70 + 6$  |  $99 - 9$  |  $75 - 5$  |  $96 - 6$

# Ондықтармен санау



1.

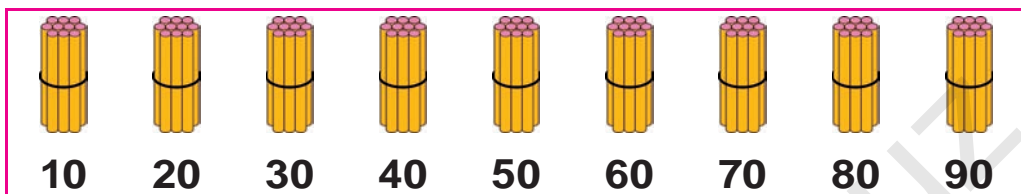
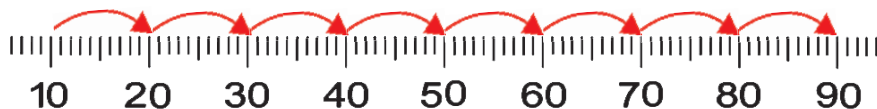

Ондықтар	Бірліктер			
1	0	он	$10 + 10$	$20 - 10$
2	0	жиырма	$20 + 10$	$30 - 10$
3	0	отыз	$30 + 10$	$40 - 10$
4	0	қырық	$40 + 10$	$50 - 10$
5	0	елу	$50 + 10$	$60 - 10$
6	0	алпыс	$60 + 10$	$70 - 10$
7	0	жетпіс	$70 + 10$	$80 - 10$
8	0	сексен	$80 + 10$	$90 - 10$
9	0	тоқсан	$80 + 10$	$90 - 10$



2.  $10 + 10 = \square\square$

1 ондық + 1 ондық = 2 ондық

$10 + 10 = 20$

3. Жазылуын түсіндір:

$20 + 20 = \square\square$

2 ондық + 2 ондық = 4 ондық

$20 + 20 = 40$

$50 - 10 = \square\square$

5 ондық - 1 ондық = 4 ондық

$50 - 10 = 40$

$20 + 10$

$40 - 20$

$70 + 10$

4. 9 ондықтан құралған санды жаз.

4 ондықтан құралған санды жаз.









# Геометриялық фигуралар. Мәтінді есептер

Ұзындық және оның бірлігі:  
сантиметр



1.

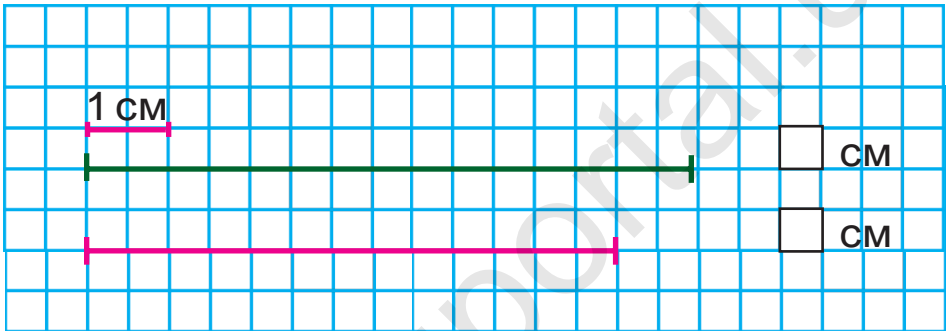
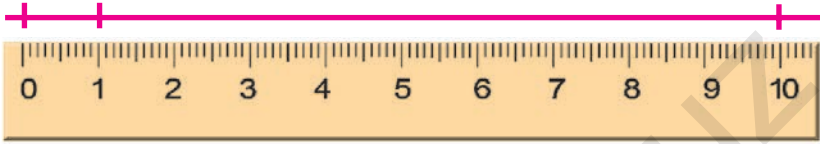

2. Қарындаштың ұзындығын өлше:

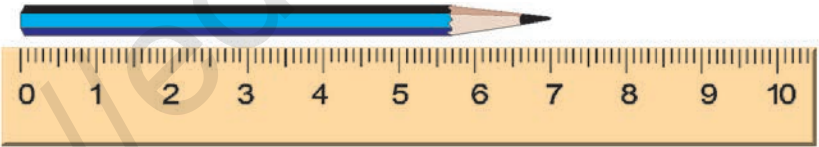

3. Таспалардың ұзындығын өлше және оларды дәптеріңе сыз:

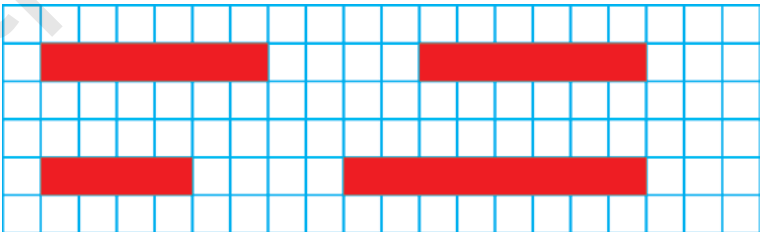

4.  $(30 + 20) + 8$

$(50 + 20) + 4$

$(60 - 40) + 5$

$(90 - 30) + 7$





1. Сызғыштан дұрыс пайдалан:

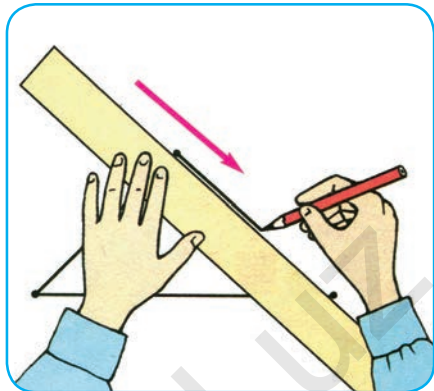
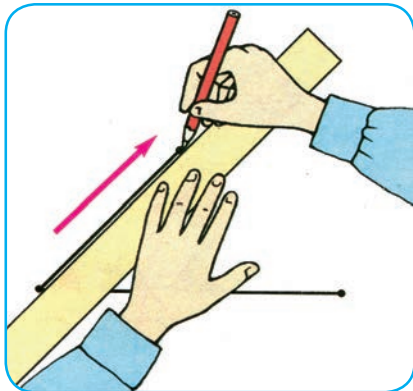

2. Фигураларды дәптеріңе сыз:

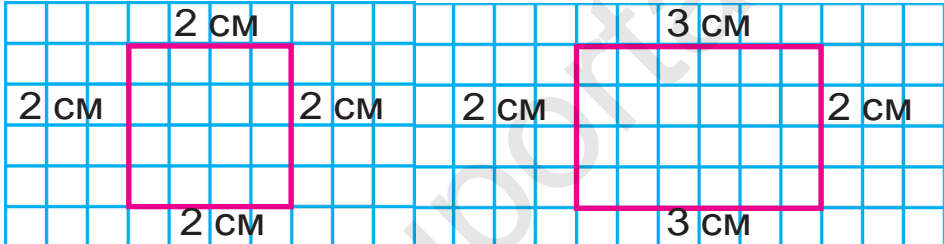

3. Жылыжайда 50 түп гүл көшеті егілген еді. Содан 20 түп гүл гүлдеді. Неше түп гүл әлі гүлдемеген?



4.



5. Фигуралардың атын ата:

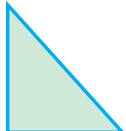

6. Сандарды таңба қосылғыштарының қосындысы көрінісінде өрнекте:

$37 = 30 + 7$   
 $96 = 90 + \square$   
 $78 = 70 + \square$

$53 = 50 + \square$   
 $22 = 20 + \square$   
 $85 = 80 + \square$

$66 = 60 + \square$   
 $44 = 40 + \square$   
 $29 = 20 + \square$





7. Сыныптағы бірінші партадан тақтаға дейінгі қашықтықты қадамдап өлше:



8. Екі жақын қосылғыштарды қосындымен алмастырып, қолайлы тәсілмен есепте:

$$7 + 3 + 2$$

$$40 + 30 + 9$$

$$30 + 10 + 7$$

9. Фигуралардың әрбір қабырғасын сызғыш жәрдеміңде өлше:

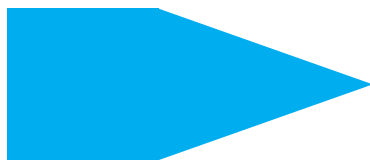

10. Екі кесінді сыз. Бірінші кесіндінің ұзындығы 7 см, екінші кесінді одан 4 см ұзын болсын.



$$11. 70 + (2 + 7)$$

$$(60 - 20) + 7$$

$$20 + (8 - 3)$$

$$50 + (4 + 3)$$

$$(30 + 50) + 8$$

$$30 - (7 + 2)$$

$$40 + (9 - 5)$$

$$(70 - 50) + 4$$

$$80 + (9 - 2)$$



# Кесіндінің ұзындығы. Екі нүкте арасындағы арақашықтықты 1 сантиметр анықтықта өлшеу және салыстыру

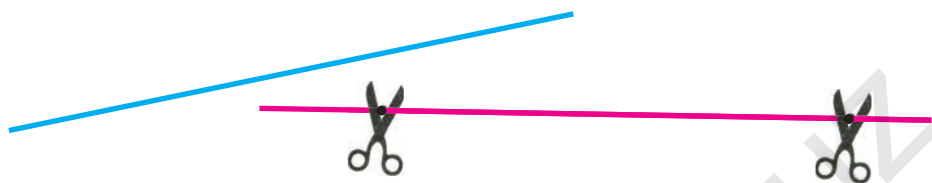

1. Кесінділерді өлше және салыстыр:



2. Әрбір фигурада қанша кесінді бар?



3. Әнуар 7 см, ағасы одан 2 см ұзын кесінді сызды. Ағасы сызған кесіндінің ұзындығы неше сантиметр?



4. Кесте негізінде есеп құрастыр және оны шеш:

Бар еді	Жейілді	Қалды

5.  $20 + \square = 29$

$26 - \square = 20$

$38 - \square = 30$

$40 + \square = 45$

$50 + \square = 53$

$67 - \square = 60$



6. Сызғыштың жәрдемімен нүктелер тізбегі мен реңіне қарай біріктіріңіз. Қандай фигура пайда болды? Дәптеріңізге сыз:

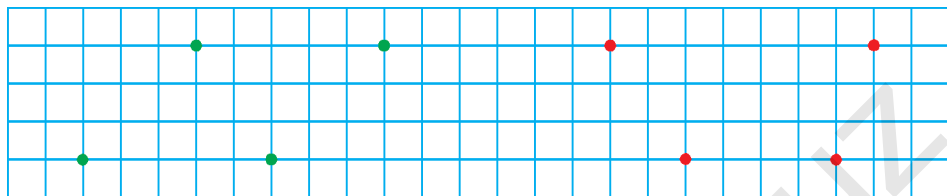

7.

$90 - \bigcirc = 80$	$\bigcirc + 20 = 70$
$\bigcirc + 10 = 90$	$\bigcirc - 30 = 30$
$80 - \bigcirc = 40$	$50 + \bigcirc = 60$

8. Сынып кітапханасы үшін 50 кітап сатып алынды. Олардан 30-ы ертек, ал қалғандары өлең кітаптар. Қанша өлең кітап сатып алынды?



9. Фигураларды салыстыр:

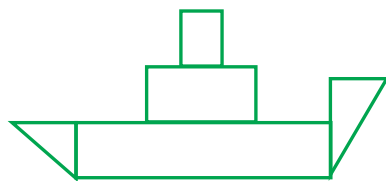
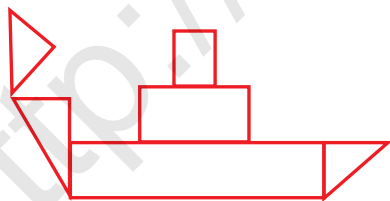

10. Амал белгілерін теңдік дұрыс болатындай етіп қой:

$70 \square 20 = 90$

$50 \square 40 = 10$

$50 \square 10 = 60$

$80 \square 40 = 40$

$60 \square 20 = 80$

$70 \square 50 = 20$

$30 \square 30 = 60$

$90 \square 20 = 70$

$20 \square 30 = 50$



**?** 11. Бірінші кесінді екінші кесіндіден неше сантиметр қысқа? Үшінші кесінді екінші кесіндіден неше сантиметр ұзын?

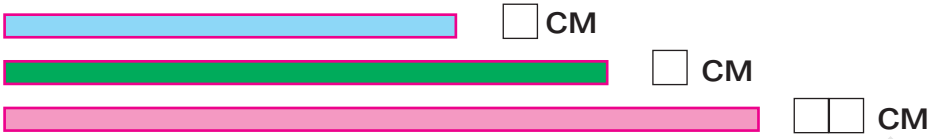

**☀** 12. Мектеп ауласына отырғызу үшін 30 түп раушангүл көшеті алып келінді. Раушангүлдің 20 түбі қызыл, қалғандары болса ақ. Ақ реңдегі раушангүл көшеттері нешеу?

**▲** 13. Сызбаның әрбірінде қаншадан кесінді бар?



14. $40\text{ см} + 50\text{ см}$	$90\text{ см} - 60\text{ см}$
$20\text{ см} - 10\text{ см}$	$30\text{ см} + 20\text{ см}$

15. Фигуралардың қабырғаларын сызғыш жәрдеміңде өлше:

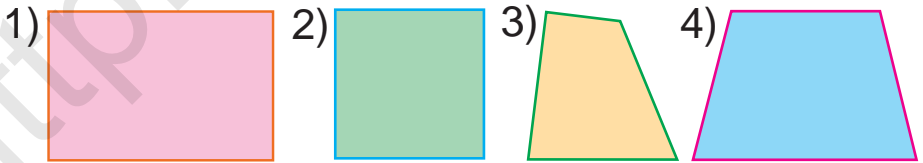

**☀** 16. Бірінші жүйекте 40, екінші жүйекте болса 20 қияр бар. Екі жүйекте неше қияр бар?



17. $40 + 40$	$23 - 3$	$80 + 5$	$36 - 6$
$60 - 20$	$70 + 8$	$59 - 9$	$40 + 7$

# Берілген ұзындықта кесінді жасау



1. Берілген кесінділерді дәптеріңе сыз және олардың ұзындықтарын анықтап жаз.

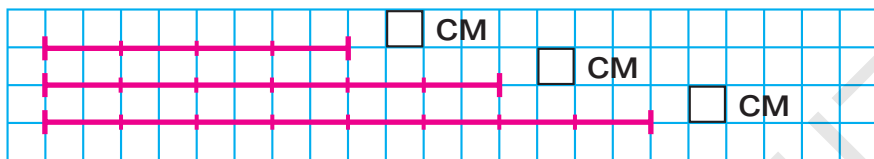

2. Автопаркте 12 жеңіл машина бар еді. Таңертең одан 9-ы белгіленген бағыттар бойынша жұмысқа шығып кетті. Автопаркте неше машина қалды?



3.

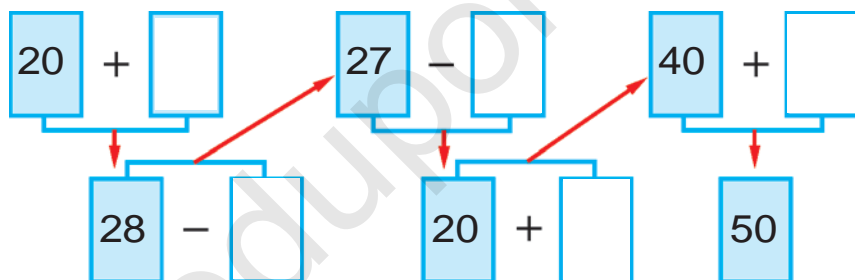

4. Кесте негізінде есеп құрастыр және оны шеш:

Бар еді	Сатылды	Қалды
12 дана велосипед	4 дана велосипед	? дана велосипед

5. Сынық сызықтарды сызғыш жәрдемінде өлше.



6.  $20 + 8 \square 28$  |  $45 - 5 \square 55$  |  $50 + 2 \square 31$   
 $37 - 7 \square 50$  |  $60 + 9 \square 70$  |  $89 - 9 \square 89$







# Бұрыш және оның түрлері



1. Тікбұрыштар.

Тікбұрыштан үлкен және кіші бұрыштар.

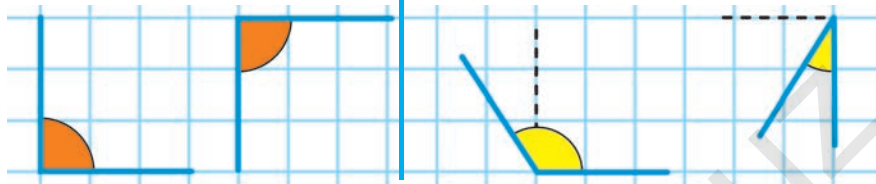

**Тікбұрыштан кіші болған бұрыш өткір бұрыш деп аталады.**

**Тікбұрыштан үлкен болған бұрыш өтпес бұрыш деп аталады.**



2. Сурет және қысқа жазу бойынша есеп құрастыр және оны шеш:

Бар еді – 30 құты кәмпит

Сатылды – 20 құты кәмпит

Қалды – ? құты кәмпит



3. 1) Тікбұрыштан кіші болған бұрыштардың тәртіп санын жаз;

2) Тікбұрыштан үлкен болған бұрыштардың тәртіп санын жаз:

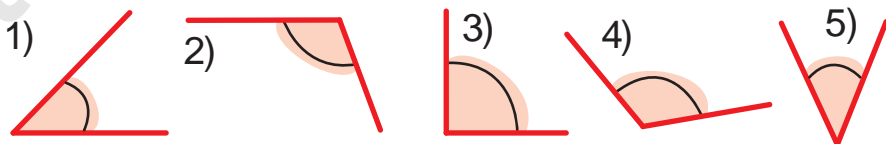

4.  $50 \square 2 = 52$

$35 \square 5 = 30$

$20 \square 4 = 24$

$67 \square 7 = 60$

$40 \square 8 = 48$

$56 \square 6 = 50$

$30 \square 6 = 36$

$29 \square 9 = 20$

$40 \square 3 = 43$





# Көпбұрыштар



1. Әрқайсы фигураның атын айт:

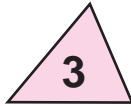
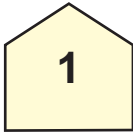

Көпбұрыштардың бұрыш және жақтары үшеу, төртеу, бесеу және одан артық болады.

2. Көпбұрыштардың қабырғаларын сана:

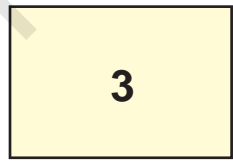
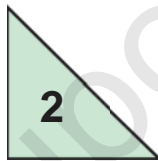
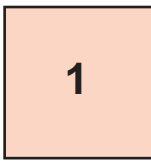

3. Сурет негізінде есеп құрастыр және оны шеш:



Барлығы – 16 дана



4.

2-ге арттыр

10	11	12	14	15	17	18	20



5.  $40 + \square = 43$

$89 - \square = 80$

$50 + \square = 56$

$72 - \square = 70$

$20 + \square = 25$

$56 - \square = 50$





6. Әрбір фигураның атын айт.

Барлық фигураларды бір сөзбен не деп айту мүмкін?



7. Кестеден жауабы бірдей болған мысалдарды тап:

$60+9$	$54-4$	$60+20$	$47-7$
$95-5$	$68+1$	$45-10$	$30+5$
$20+20$	$82-2$	$70+20$	$58-8$

8. Кітапханада 18 «Билимдон» журналы бар еді. Кітапханашы бірнеше журналды оқушыларға оқу үшін тарқатқаннан соң 8 журнал қалды. Кітапханашы неше журнал тарқатқан?



9. Қандай көпбұрыш түсіп қалған?

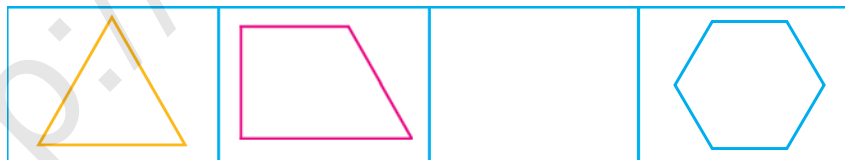

10.  $20 + \square = 28$  |  $44 - \square = 40$  |  $50 + \square = 59$   
 $95 - \square = 90$  |  $50 + \square = 55$  |  $76 - \square = 70$



11. Екі жақын қосылғыштарды қосындымен алмастырып, қолайлы тәсілмен есепте:

$7+3+2$

$40+30+9$

$30+10+7$

# Төртбұрыш және оның түрлері



1. Әрбір фигураның атын айтыңдар. Оларды бір сөзбен не деп айту мүмкін?

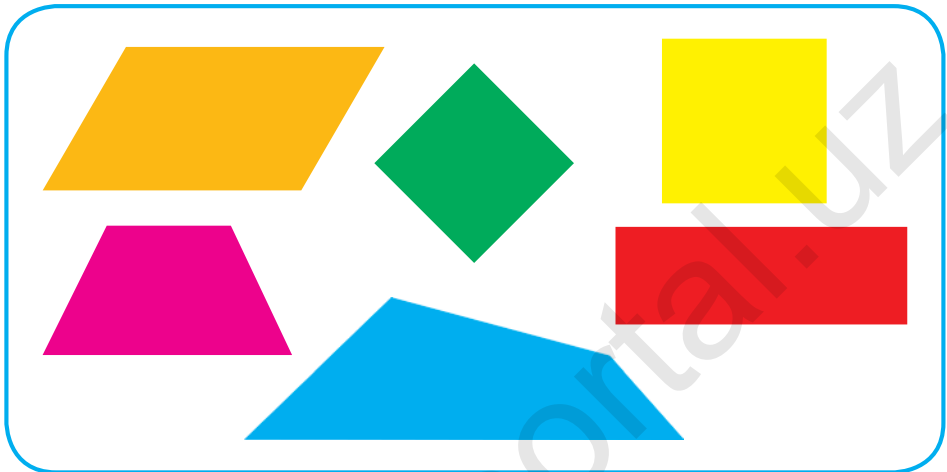

2. Сандардың қосындысын есепте: 30 және 9, 60 және 5, 80 және 2, 68 және 1.



3. Есептерді түсіндіріп шеш:

$23 + 7 = \square\square$        $30 + 20 = \square\square$        $50 + 4 = \square\square$   
 $27 - 4 = \square\square$        $20 + 7 = \square\square$        $54 - 30 = \square\square$   
 $24 + 3 = \square\square$

4. Балалар алаңы құрылысында 16 кірпіш қалаушы, одан 7-еу кем сыбақшы істеді. Құрылыста неше сыбақшы істеген?



- |             |          |          |          |
|-------------|----------|----------|----------|
| 5. $60 + 8$ | $87 - 7$ | $40 + 2$ | $59 - 9$ |
| $75 - 5$    | $30 + 5$ | $47 - 7$ | $70 + 3$ |



# Есептер шешуді үйренеміз.

## Есептің шарты мен сұрақтары



1. Мұратта 4 кекілік бар. Әкбарда одан 3 кекілік артық. Әкбарда неше кекілік бар?

Мұратта – 4 кекілік ←  
 Әкбарда – ?, 3 артық кекілік →

2. Мысалдарды түсіндіріп шеш:

$40 + 10 = 50$	$70 + 20 = \square\square$	$50 + 30 = \square\square$
$10 + 40 = 50$	$20 + 70 = \square\square$	$30 + 50 = \square\square$

$50 - 40 = 10$	$90 - 70 = \square\square$	$80 - 50 = \square\square$
$50 - 10 = 40$	$90 - 20 = \square\square$	$80 - 30 = \square\square$

3. Қысқа жазу бойынша есеп құрастыр және оны шеш:

1-тәрелкеде – 11 алхоры ←  
 2-тәрелкеде – ?, 6-ау кем →



4. Қандай фигураларды көріп тұрсың?  
 Аттарын айтып бер:

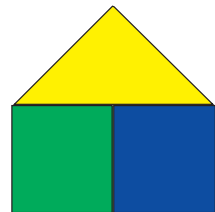

5. Бір бағанға сандардың қосындысын, екінші бағанға сандардың айырмасын жаз және оны шеш:

$57 - 40$	$39 + 10$	$75 - 30$
$60 + 30$	$48 - 20$	$64 - 20$





6. Бірінші сыныпта 30 оқушы, екінші сыныпта одан 2 оқушы артық. Екінші сыныпта неше оқушы бар?



7. Жауабы 10 шығуы үшін қайсы жақтан жүру керек?

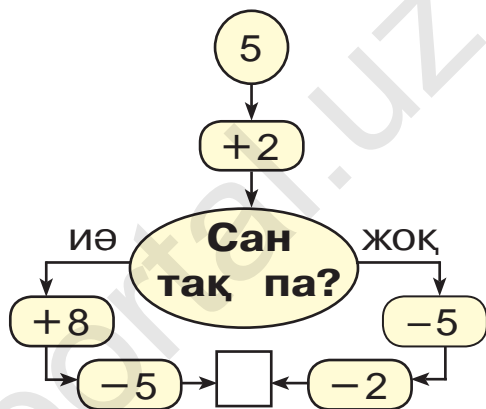
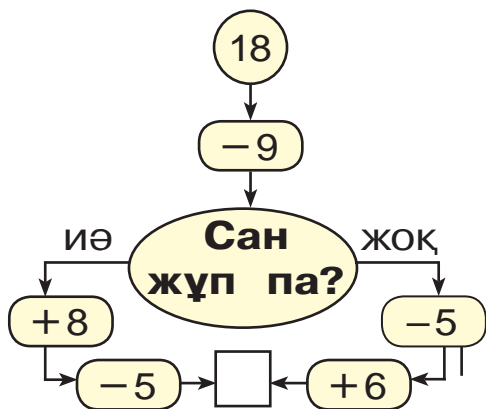

8. Қораптағы жұмыртқалардың санын сана. Таңертеңгілік асқа 4 жұмыртқа алынды. Қорапта қанша жұмыртқа қалды?

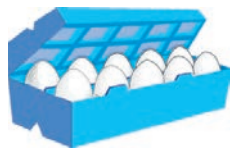

9.  $80 + \bigcirc = 82$

$39 - \bigcirc = 30$

$\bigcirc - 5 = 70$

$\bigcirc + 0 = 29$

$60 + \bigcirc = 69$

$\bigcirc - 7 = 90$



10. Бірінші сыныпта 30 оқушы, екінші сыныпта одан 2 артық оқушы бар. Екінші сыныпта неше оқушы бар?



# Жай және құрамды есептер



1. Есеп құрастыр және оны шеш:



2.  $40 + 5 \square 57$  |  $69 - 9 \square 48$  |  $80 + 1 \square 81$   
 $98 - 8 \square 75$  |  $50 + 6 \square 72$  |  $32 - 2 \square 30$



3. Валижанда  бар еді.

Толибжанның кептерлері бұдан 4-еу кем.  
 Толибжанда неше кептер бар?

Валижанда – 7-еу ← 

	-	4	=	
--	---	---	---	--

Толибжанда – ?, 4-еу кем



4. Фигураларды салыстыр:

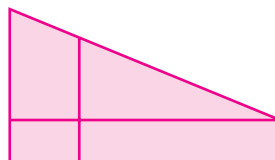
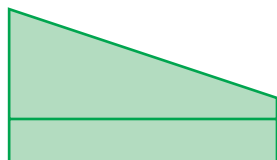

5. Балықшы өзеннен 15 сазан және лақа балық аулады. Сазан балықтар 8 болса, лақа балықтар нешеу?





## Екі амалды есептер



1. Бірінші қорапта 5 қарындаш бар. Екінші қорапта біріншідегіден 2 қарындаш артық. Екі қорапта неше қарындаш бар?



1-қорапта – 5 қарындаш  
 2-қорапта – ?, 2 қарындаш артық } ?  
 Шешуі:

- 1)  $5 + 2 = 7$  екінші қораптағы қарындаш.
- 2)  $5 + 7 = 12$  екі қораптағы қарындаштар.



2. Төмендегі сандар қатарына қайсы сандар жетіспейді?



3. Сурет және қысқа жазу негізінде есеп құрастыр және оны шеш:

1-шелекте – 19 кг  
 2-шелекте – ?, 9 кг кем } ?



19 кг    ? 9 кг  
 кем  
 ? кг

4. Бірінші автобуста 22 жолаушы бар, ал екінші автобуста болса одан 10 жолаушы кем. Екі автобуста қанша жолаушы бар?



5. $30 + \square = 38$	$56 - \square = 50$	$70 + \square = 78$
$29 - \square = 20$	$70 + \square = 72$	$27 - \square = 20$





6. Сандар қатарын жалғастыр:

- 1) 15, 20, 25, ..., ..., ..., 45, ..., ..., 60;  
 2) 10, 20, ..., ..., ..., ..., 70, ..., ..., 100.



7. Кестеден жауабы бірдей болған сандарды тап:

$69 - 2$	$57 + 3$	$78 - 6$	$49 + 1$
$70 + 2$	$52 - 2$	$60 + 7$	$80 - 20$
$46 - 16$	$58 + 20$	$58 - 28$	$48 + 30$



8. Бір орамда 26 м, екінші орамда 14 м атлас бар. Екі топта неше метр атлас бар?

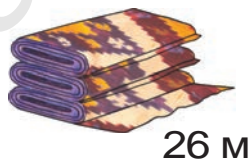

26 м



14 м



9.

$$\textcircled{40} + \textcircled{\quad} = \textcircled{47}$$

$$\textcircled{72} - \textcircled{\quad} = \textcircled{70}$$

$$\textcircled{\quad} - \textcircled{5} = \textcircled{60}$$

$$\textcircled{\quad} + \textcircled{9} = \textcircled{29}$$

$$\textcircled{\quad} + \textcircled{6} = \textcircled{56}$$

$$\textcircled{58} - \textcircled{\quad} = \textcircled{50}$$

10. Демалыс күні Жәмшіт әкесімен балық аулауға барды. Әкесі 17, ал Жәмшіт одан 7-еу кем балық аулады. Жәмшіт неше балық аулады? (Есепке сұрақ қойғандарыңда, ол екі амалмен шешілетін болсын.)



11.  $40 + 7$  |  $55 - 5$  |  $60 + 20$  |  $30 - 10$   
 $29 - 9$  |  $40 + 3$  |  $80 - 30$  |  $70 - 40$



# Қосу және азайту амалдарының мағынасына тиісті мәтінді есептер



1. Азық-түлік дүкеніне 30 қорап науат пен қант келтірілді. Науатты қорап 20 болса, неше қорап қант келтірілген?

2. Есеп құрастыр және оны шеш:

1) Тауық – 8 дана )  
   Әтеш – 2 дана ) ? дана

2) Тауық – 8 дана )  
   Әтеш – ? дана ) 10 дана

3) Әтеш – 2 дана )  
   Тауық – ? дана ) 10 дана



3. Ділшат бірінші күні 10 бет, екінші күні 8 бет кітап оқыды. Ділшат осы екі күн ішінде неше бет кітап оқыған?



4. Берілген сурет негізінде есеп құрастыр және оны шеш:



24 кг

және

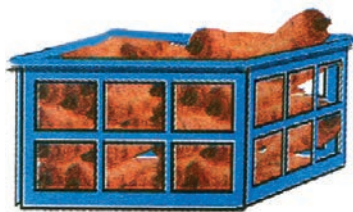

22 кг



Жұмсалды – 20 кг

Қалды – ? кг

5.  $(30 + 20) + 8$

$(50 + 20) + 4$

$(60 - 40) + 5$

$(90 - 30) + 7$





## «...дейін асыру», «...дейін азайту» анықтамаларына тән есептер

 1. Табиғат мұражайына бірінші сыныптан 27 оқушы, екінші сыныптан 2 оқушы артық барды. Табиғат мұражайына екінші сыныптан неше оқушы барды?

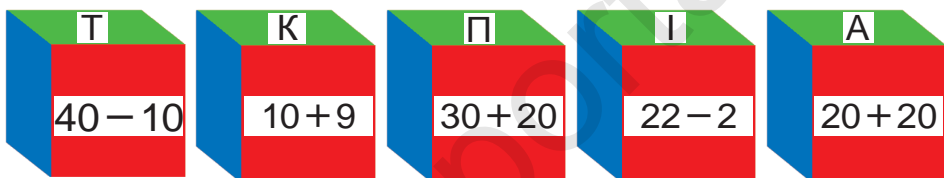
 2. Есептердің жауабын өсіп бару тәртібінде орналастыр. Қандай сөз пайда болды?



 3. Бір байламда 25, екіншісінде болса 20 дәптер бар. Екінші байламда бірінші байламдағыға қарағанда қанша кем дәптер бар? Бірінші байламда екінші байламдағыға қарағанда қанша көп дәптер бар?

 4. Көпбұрыштардың қабырғаларын сызғыш жәрдемінде өлше:



 5. 

$30 + 24$	$80 + 12$	$60 + 32$	$53 + 10$
$80 + 17$	$70 + 17$	$60 + 24$	$40 + 16$
$20 + 15$	$30 + 13$	$70 + 30$	$60 + 15$



# Масса өлшем бірлігі: килограмм



1.



Суретте берілген таразы тастарының массасы қанша килограммдығын айт.

2.



Суретке қарап тұз бен ұнның массасы қанша килограммдығын айт.



3. Асқабақ 8 кг, ал қарбыз болса одан 2 кг кем. Қарбыздың массасы неше килограмм?

Асқабақ – 8 кг ←  
Қарбыз – ?, 2 кг кем

8		2	=	
---	--	---	---	--



4. Мысалдарды түсіндіріп шеш:

$21 + 9 = \square$	$30 - 10 = \square$	$20 + 9 = \square$
$25 - 4 = \square$	$20 + 5 = \square$	$29 + 1 = \square$
		$30 - 5 = \square$



5. Сурет бойынша есеп құрастыр және оны шеш:

Қауын – 8 кг ←  
Қарбыз – ?, 2 кг ауыр

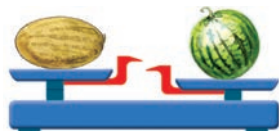



6. Кесте бойынша есеп құрастыр және оны шеш:

Бар еді	Жұмсалды	Қалды
23 кг пияз	3 кг	? кг



7. Алма жәшігінің массасы 10 кг, алмұрт жәшігінің массасы одан 3 кг жеңіл. Алмұрт жәшігінің массасы неше килограмм?



10 кг



?

3 кг жеңіл



8. Кестеден жауабы бірдей болған мысалдарды тап:

$40 + 7$	$50 + 30$	$95 - 5$	$38 - 8$
$83 - 3$	$20 + 27$	$36 - 6$	$40 + 10$
$60 + 9$	$79 - 10$	$60 + 30$	$54 - 4$



9. Бірінші торда 10 дана, екінші торда біріншіге қарағанда 3 дана кем тотықұс бар? Екінші торда неше тотықұс бар?

1-торда – 10 дана тотықұс ←

2-торда – ?, 3 дана кем ←



10.  $70 + 30$                        $27 - 20$                        $30 + 30$   
 $86 - 60$                        $49 + 10$                        $57 - 20$





# Сығым өлшем бірлігі: литр



1. Бір литрлі, үш литрлі, бес литрлі банкаға неше стақан су сыятындығын өлшеп көр.

2. Шелекке 10 л су сыяды. Егер шелекте 6 л (4 л, 7 л) су болса, оған тағы неше литр су құю мүмкін?



3.  $10 + 3 \square 9$  |  $19 - 9 \square 10$  |  $36 + 2 \square 40$   
 $18 - 8 \square 5$  |  $15 + 4 \square 19$  |  $19 - 9 \square 20$



4. Сурет негізінде есеп құрастыр және оны шеш:



6 кг



3 кг

? кг

6	3	=	
---	---	---	--



10 л



? л

17 л

1	7	1	0	=	
---	---	---	---	---	--

5. Бір бидонда 10 л, екіншісінде одан 3 л кем мақта майы бар. Екінші бидонда неше литр май бар?



6.  $20 + 2$        $35 + 3$        $19 + 1$        $24 - 4$   
 $17 - 7$        $16 - 6$        $10 + 6$        $23 + 5$





7. Түсіндіріп шеш:

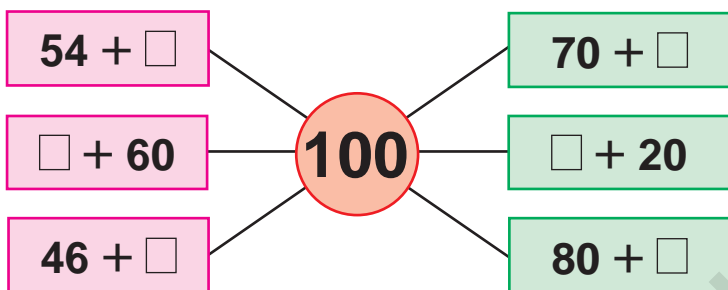

8. Есеп құрастыр және оны шеш:

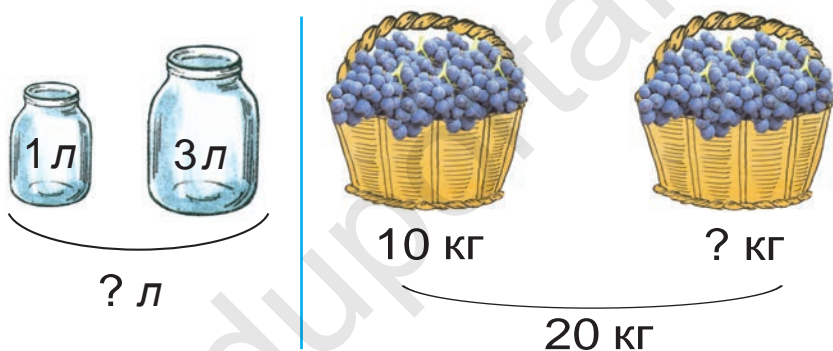



9. Бірінші бидонда 10 л, екіншісінде одан 4 л артық сүт бар. Екінші бидонда неше литр сүт бар?

10.

					$3 + 2 = 5$
					$\square + 2 = 6$
					$\square + 2 = 7$
					$\square + 4 = 8$
					$\square + 5 = 9$

## Өтілгендерді қайталау

 1. Мектеп асханасына 30 үлкен және 14 кіші шәйнек келтірілді. Мектеп асханасына барлығы болып қанша шәйнек келтірілген?

 2. Жауабы 90 шығуы үшін қайсы жақтан жүру керек?

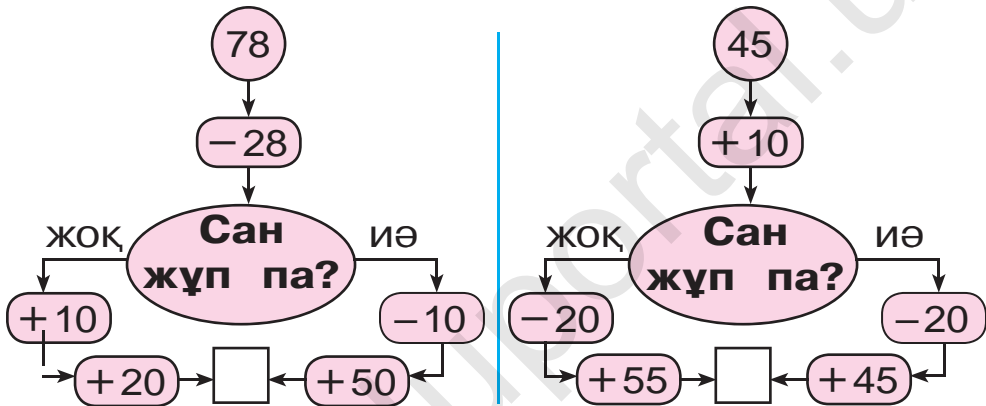

 3. Бөшкеде 10 шелек су бар еді. Гүлдерді суару үшін 7 шелек су алынды. Бөшкеде неше шелек су қалды?



 4. Фигуралардың қайсы бірінде бұрыш жоқ?

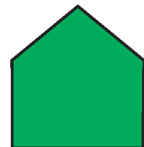
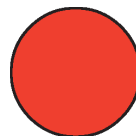
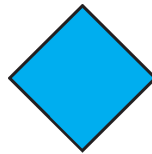

 5. Амал белгілерін теңдіктер дұрыс болатындай етіп қой:

$90 \square 4 = 94$

$57 \square 7 = 50$

$60 \square 2 = 62$

$40 \square 9 = 49$

$86 \square 6 = 80$

$73 \square 3 = 70$



# Геометриялық фигуралар. Логикалық түсініктер

## Заттардың айнадағы бейнесі

1. Бейнеленген заттың көрінісін түсіндір:



2. Жүгіру жарысына 46, ұзындыққа секіру бойынша 20 оқушы қатысты. Спорт жарысына барлығы болып неше оқушы қатысты?

3. Бейнеленген суреттердің көрінісін жалғастырып дәптеріңе сыз және оны боя.

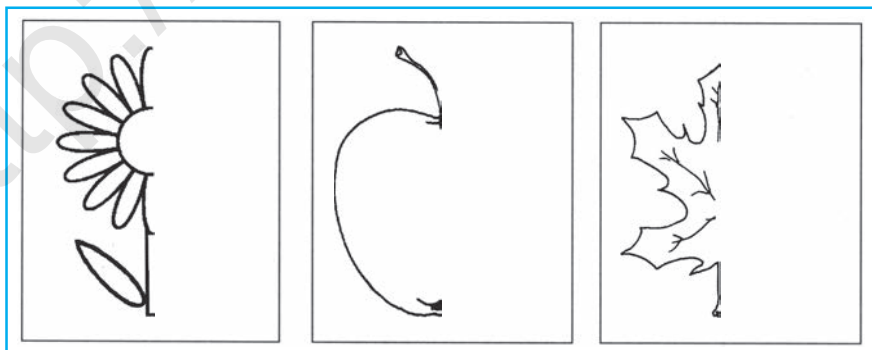



4.  $28 - 10$  |  $50 + 17$  |  $36 - 20$  |  $60 + 10$   
 $40 + 14$  |  $68 - 60$  |  $20 + 19$  |  $57 - 20$

# Симметрия

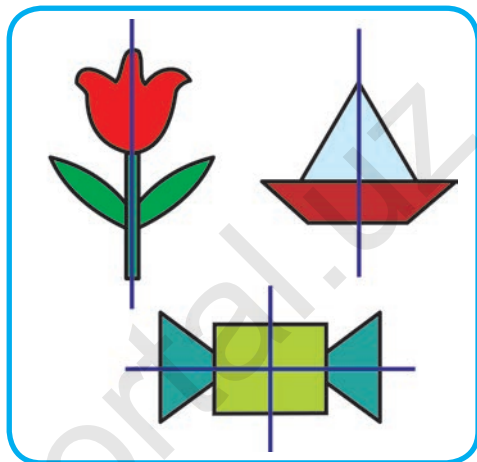
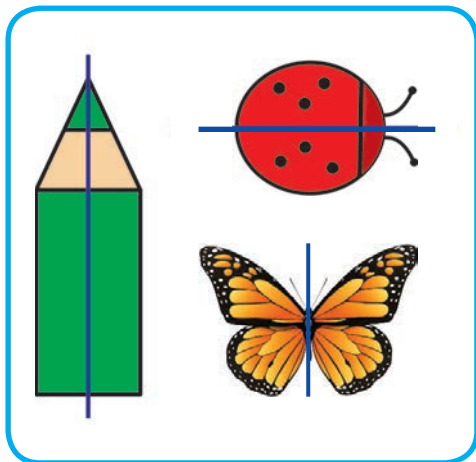
-  1. Бейнеленген суреттерден симметрия оғын тауып көрсет:



-  2. Әнуар 12 парақты дәптердің 7-ші парағын толтырды. Дәптердің толтырылмаған неше парағы қалды?

-  3. Әрбір фигураның бөліктері қалай пайда болады, олардағы симметрия оғын тауып көрсет.

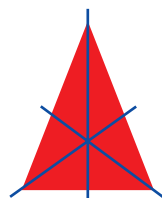
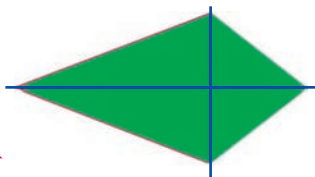
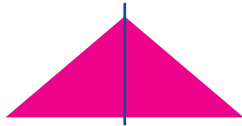

4. Төмендегі сандардың әрбірінде неше ондық және неше бірлік бар?

39, 61, 42, 57, 63, 55, 46, 25, 38, 70

-  5.  $20 + \square = 27$  |  $65 - \square = 60$  |  $40 + \square = 48$   
 $17 - \square = 10$  |  $50 + \square = 56$  |  $72 - \square = 70$

# Симметриялық фигуралар.

## Нүктелер, кесінділер.

### Көпбұрыштардың симметриялығы



1. Төртбұрышты неше бөлікке ажырату мүмкін?



2. Бірінші себетте 48, екіншісінде одан 8 кем апельсин бар. Екі себетте барлығы болып неше апельсин бар?



3. Суретте бейнеленген барлық фигуралардың атын айт және оларды бір сөзбен не деп атау мүмкін? Әрбір фигура неше бөліктен тұрады?

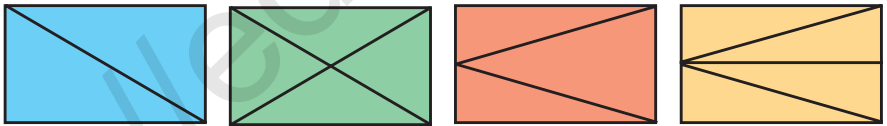

4. Кім мәреге тез жетеді?

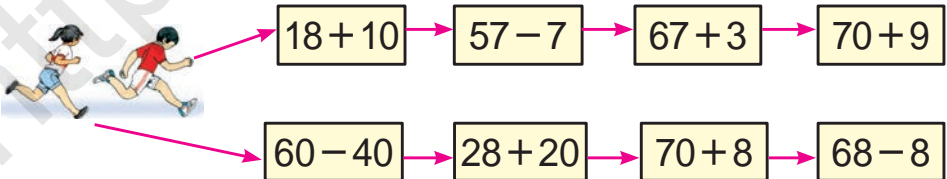

5.  $40 + 17$

$80 - 30$

$30 + 30$

$60 - 20$

$50 + 10$

$70 - 40$

$50 + 19$

$90 - 60$

$50 + 50$



# Бір немесе бірнеше симметрия оғына ие фигураларға мысалдар



1. Квадраттың бөліктері қандай пайда болған?

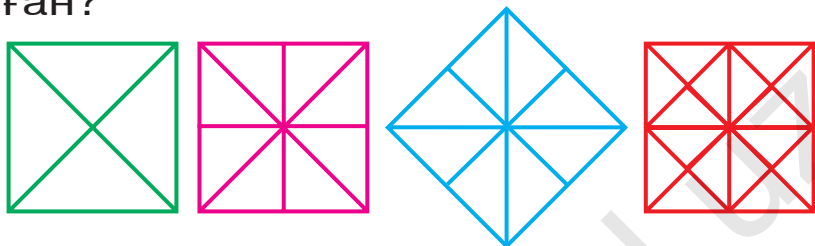

2. Әрбір бөлік қандай пайда болды?

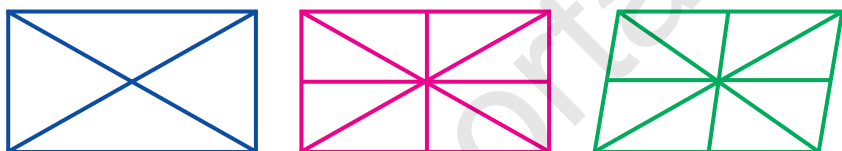

3. Трактордың багінде жұмыс басталғанда 37 л жанармай бар еді, жұмыс соңында 7 литр қалды. Неше литр жанармай жұмсалған?

4. Әрбір бөлік қандай пайда болғанын түсіндір:

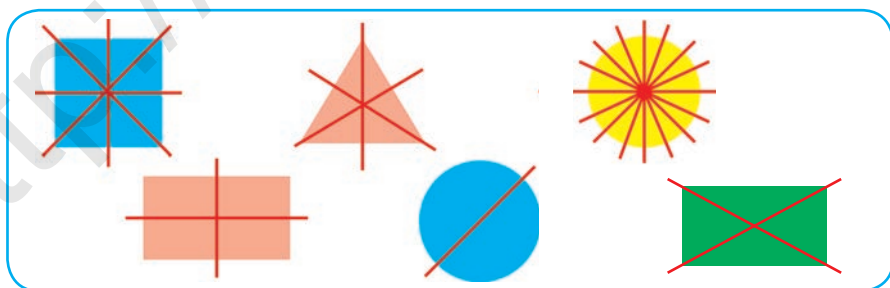

5. Бірінші қатарға жұп сандарды, екінші қатарға тақ сандарды өсу тәртібімен жаз:

20, 31, 27, 34, 45, 16, 57, 68, 86, 75.



# Заттың құрылымы

1. Суретте бейнеленген заттардың атын ата:



2. Мектеп асханасына 14 кг ұн алып келінді. 4 кг ұннан самса, 6 кг ұннан тәтті күлше пісірілді. Асханада неше килограмм ұн қалды?

3.  $96 = 90 + 6$  |  $44 = 40 + \square$  |  $22 = 20 + \square$   
 $66 = 60 + \square$  |  $48 = 40 + \square$  |  $88 = 80 + \square$

4. Әрбір суретте қанша үшбұрыш, қанша төртбұрыш бар?

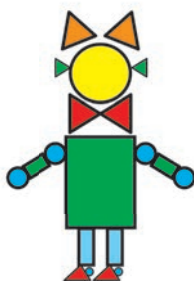
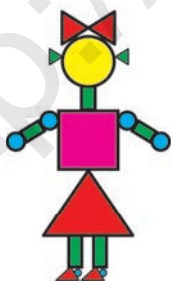

5. Сандарды қойғанда теңдіктер дұрыс болсын:

$20 + \square = 27$

$48 - \square = 40$

$80 + \square = 86$

$36 - \square = 30$

$50 + \square = 57$

$72 - \square = 70$



# Түсініктер: бірдей формада, түрлі формада



1. Суреттегі формалардың аттарын ата. Бұл формалар қандай фигуралардан пайда болған?

1)

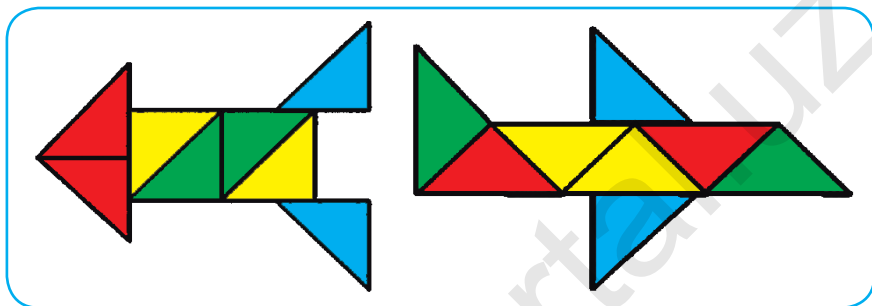

2)

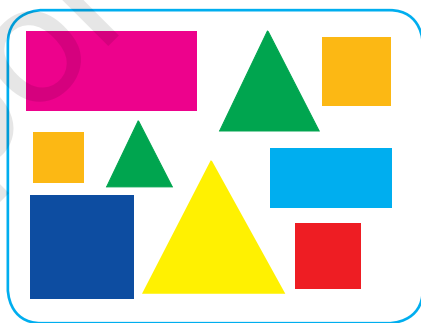

2. Мысалдарды ыңғайлы тәсілмен есепте:

$$58 + 1 = (50 + 8) + 1 = 50 + (8 + 1) = 59$$

$$46 + 1$$

$$52 + 7$$

$$55 + 4$$

$$56 + 3$$

$$37 + 1$$

$$48 + 1$$

$$24 + 5$$

$$63 + 6$$

3. Сәлім мен Кәрім 90 стол жасау керек еді. Сәлім 28, Кәрім болса 21 стол жасады. Сәлім мен Кәрім және неше стол жасаулары керек?



4.  $(20 + 20) + 7$

$$(60 - 20) + 5$$

$$(70 - 30) + 6$$

$$(50 + 30) + 9$$





1. Мысалдардың жауабын тап:

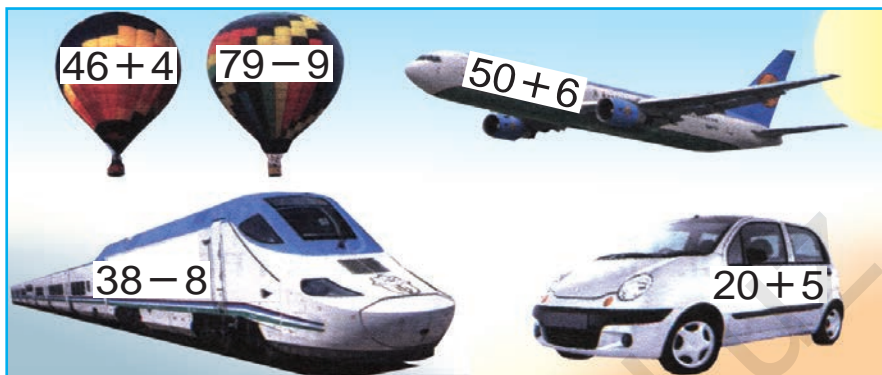

2. 1) 29, 39, 49, 59, 69, 79, 89, 99 сандарынан бір сан кейін келетін көрші сандарды айт;

2) 90, 80, 70, 60, 50, 40, 30, 20, 10 сандарынан бір сан алдын келетін көрші сандарды айт;

3) 91, 92, ..., ... сандарын 100-ге дейін толтыр.



3. Сурет және қысқа жазу негізінде мәселе тұз және оны шеш:

Шелекте – 14 кг  
 Себетте – ? кг, 6 кг  
 ауыр

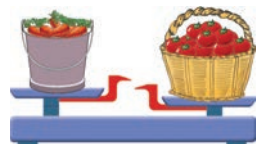

4. Түсіріп қалдырған сандарды айт:

10 20   50  70  90



5.  $70 - 30$  |  $50 + 40$  |  $60 - 30$  |  $70 + 20$   
 $40 + 40$  |  $90 - 40$  |  $30 + 20$  |  $70 - 10$





1. Себеттердің реңіне қарап алмаларды орналастыр:



2. Дүкенде 45 тоңазытқыш бар еді. Түске дейін 10, түстен кейін 5 тоңазытқыш сатылды. Дүкенде сатылатын және неше тоңазытқыш қалды?

3.  $30 + 8$

$76 - 6$

$20 + 7$

$38 - 8$

$40 + 9$

$45 - 5$



4. Мысалдарды түсіндіріп шеш:

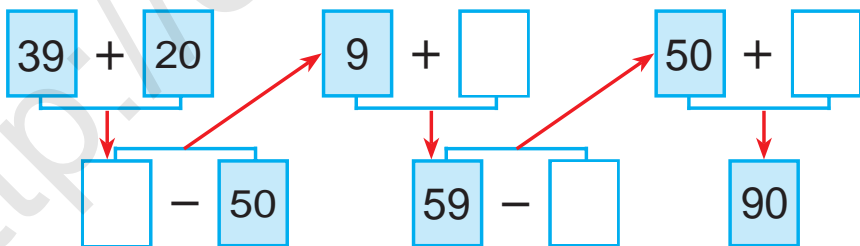

5. 80, 60, 40, 50, 20 сандарының әрбірінде неше ондық бар?



6.  $40 + 4 \square 18$

$22 - 2 \square 30$

$11 + 9 \square 12$

$33 - 3 \square 14$

$80 + 5 \square 90$

$44 - 4 \square 40$

$70 + 5 \square 75$

$36 - 6 \square 25$

$40 + 8 \square 54$



# Жай жазықты және кеңістікті фигуралар



1. Төмендегі суретте квадрат, үшбұрыш, шеңбер, бесбұрыш бейнеленген. Олар **жазықты** фигураларға мысал болады. Фигуралардың атын айт.

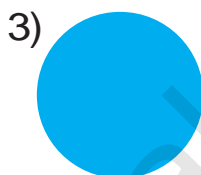
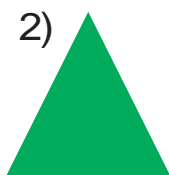

2. 1) Квадраттың қанша қабырғасы мен қанша бұрышы бар? Бесбұрышта ше?

2) Үшбұрыштың қанша ұшы және қанша бұрышы бар?



3. Сурет және қысқа жазу бойынша есеп құрастыр және оны шеш:

Бар еді – 20 кг құрма  
Сатылды – 10 кг құрма  
Қалды – ? кг құрма



4. Фигураларды дәптерлеріңе сызып оларды бояңдар:

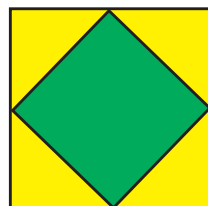
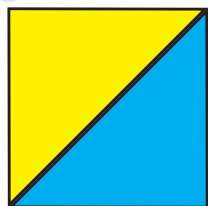

5.  $50 + (6 + 3)$   
 $60 - (8 + 2)$

$42 - (9 - 7)$   
 $30 + (6 + 4)$

$20 + (9 - 5)$   
 $85 - (3 + 2)$





6. Төмендегі суретте тіктөртбұрыш, алтыбұрыш және төртбұрыштар бейнеленген. Олар **жазықты** фигуралар.

1)



2)



3)



4)



7. Алтыбұрыштың қанша ұшы мен қанша қабырғасы бар? Тіктөртбұрышта ше?



8. Ойла, ізде, тап!



9. Феруз атасымен диқан базарынан 18 кг пияз, одан 9 кг кем картоп сатып алды. Олар неше килограмм картоп сатып алған?



10. Қағазды бүктеу жолымен қандай фигураларды жасау мүмкін?

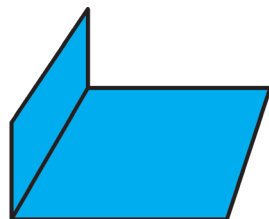
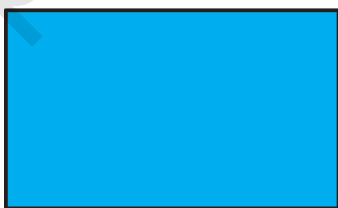

11.  $48 + 30$

$57 - 20$

$63 + 20$

$37 - 20$

$57 + 20$

$68 - 40$

$25 + 10$

$75 - 30$

$56 + 14$





1. Куб, шар, цилиндр **кеңістікті** фигураларға мысал бола алады. Әрбір цифрларға сай келген фигуралардың атын айтыңдар:

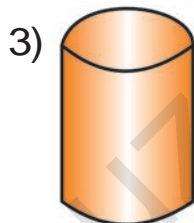
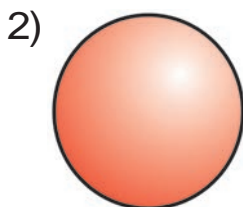
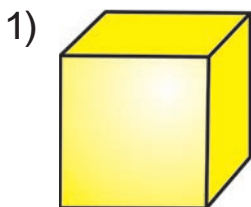

2.

$20 + \bigcirc = 28$	$72 - \bigcirc = 70$
$\bigcirc - 5 = 30$	$\bigcirc + 4 = 34$
$50 + \bigcirc = 56$	$92 - \bigcirc = 90$



3. Бұл фигуралар не деп аталады? Олардың арасынан тіктөртбұрыштарды тап:

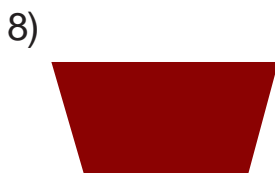
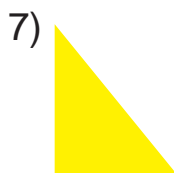
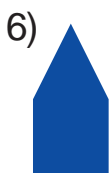
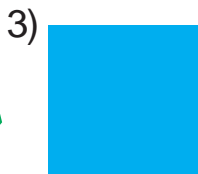

4. Бос төркөздерге сондай сандарды қойғанда, теңдік дұрыс болсын:

$50 + \square = 58$

$86 - \square = 80$

$90 + \square = 92$

$73 - \square = 70$

$20 + \square = 25$

$42 - \square = 40$





5. Конус, пирамида, параллелепипед бұлар **кеңістікті** фигуралар. Әрбір цифрға сай келген фигуралардың атын айт:

1)

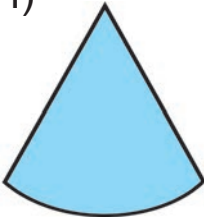

2)

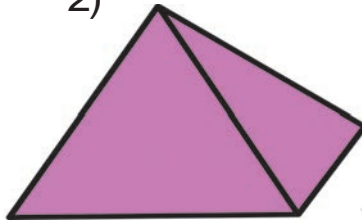

3)

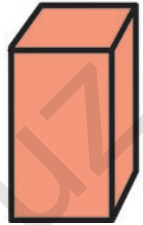

6. Мектептегі музыка үйірмесіне 29, кестешілік үйірмесіне болса 21 оқушы қатысуда. Екі үйірмеге барлығы болып қанша оқушы қатысуда?



7.  $22 + 22 = \square\square$  |  $66 - 33 = \square\square$  |  $24 + 24 = \square\square$   
 $44 - 22 = \square\square$  |  $33 + 33 = \square\square$  |  $48 - 24 = \square\square$



8. Сурет негізінде есеп құрастыр және оны шеш:



20 кг



? кг

40 кг



9. Сандарды таңба қосылғыштарының жиынтығы түрінде көрсет:

$73 = 70 + 3$

$35 = 30 + \square$

$55 = 50 + \square$

$69 = 60 + \square$

$44 = 40 + \square$

$88 = 80 + \square$

$82 = 80 + \square$

$58 = 50 + \square$

$92 = 90 + \square$







10. Төмендегі фигуралардың арасынан:  
1) жазықты фигураларды; 2) кеңістікті фигуралардың тәртіп санын айт:

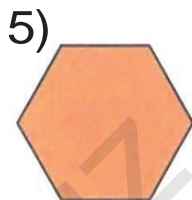
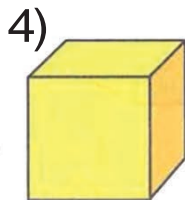
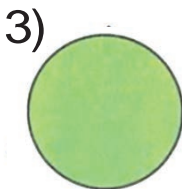
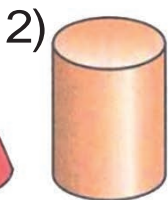
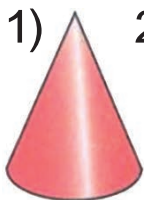

11. Бір бағанға сандардың қосындысын, екінші бағанға сандардың айырмасын жаз және оны шеш:

$$40 + 20$$

$$70 - 30$$

$$30 + 20$$

$$50 - 20$$

$$20 + 10$$

$$90 - 40$$

12. Жылыжайда 70 түп қызыл және ақ раушангүл көшеті егілген еді. Қызыл раушангүл 20 түп болса, ақ раушангүлдер нешеу?



13. 96, 38, 67, 85, 24 сандарының әрбірінде неше ондық және неше бірлік бар?



14. Санақ таяқшасынан алты квадрат баспалдақ түрінде орналастырылған. Сол таяқшалардан екеуін алғанда, төрт квадрат қалсын?

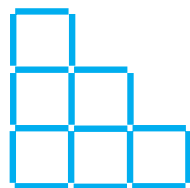

15.  $20 + (65 - 5)$

$$(70 - 30) + 9$$

$$30 + (42 - 2)$$

$$(40 + 40) + 2$$

$$80 + (22 - 2)$$

$$(50 - 50) + 8$$

# Ұзындық бірліктері: дециметр, метр. Олардың арасындағы байланыс

$$100 \text{ см} = 1 \text{ м} \quad 10 \text{ см} = 1 \text{ дм} \quad 1 \text{ м} = 10 \text{ дм}$$

Бұл таспаның ұзындығы 10 см немесе 1 дм-ге тең.



1. Столдың биіктігі 8 дм, ал орындықтың биіктігі 5 дм. Стол орындықтан неше дециметр биік?



2.  $40 \text{ см} - 20 \text{ см}$   
 $10 \text{ дм} + 30 \text{ дм}$

$50 \text{ см} + 10 \text{ см}$   
 $60 \text{ м} - 20 \text{ м}$

3. Көшенің ені 8 м. Ондағы жаяужолмен арықтың ені 4 м болса, көлік жүретін жолдың ені қанша?

4.  $19 - 9 + 4 - 10 + 5 = 9$

5. Алдын таңбалы, кейін екі таңбалы сандарды өсу тәртібімен жаз:

16, 81, 8, 46, 9, 64, 5, 63, 28, 4, 17, 3, 7, 18.

6.  $10 + 9$  |  $80 + 7$  |  $22 - 2$  |  $44 - 4$   
 $20 + 7$  |  $80 + 9$  |  $18 - 8$  |  $28 - 8$



7. Өзім мен Сапар көлде шомылуда. Жағаға шығу үшін Өзім 17 м, Сапар болса досына қарағанда 7 м кем жүзуі керек. Сапар жағаға шығу үшін қанша метр жүзуі керек?



8.  $40 \text{ см} + 10 \text{ см}$

$70 \text{ см} - 20 \text{ см}$

$50 \text{ дм} + 10 \text{ дм}$

$80 \text{ дм} - 60 \text{ дм}$

$30 \text{ см} + 10 \text{ см}$

$40 \text{ дм} - 20 \text{ дм}$



9. Қандай фигураларды көріп тұрсың? Аттарын айт:

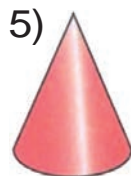
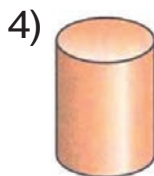
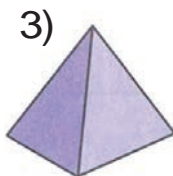
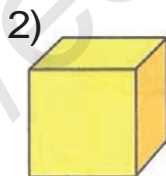

10. Бірніші кесіндінің ұзындығы 14 см, екінші кесіндінің ұзындығы одан 4 см қысқа. Екінші кесіндінің ұзындығын тап.



11.  $50 \text{ см} + 30 \text{ см}$

$90 \text{ дм} - 40 \text{ дм}$

$40 \text{ дм} + 20 \text{ дм}$

$70 \text{ дм} - 20 \text{ дм}$

$30 \text{ см} + 20 \text{ см}$

$60 \text{ см} - 20 \text{ см}$



# Қасиеттеріне қарай заттардың жиынтығын бірнеше жинақтарға ажырату

-  1. Сурет негізінде берілген гүлдер жинағы жайлы нелерді біліп алдың?



-  2. Метроның бірінші вагонында 48 жолаушы, екіншісінде одан 17 жолаушы кем еді. Екі вагонда неше жолаушы бар?

3. Жинақтағы геометриялық фигураларды түріне қарай ажырат:

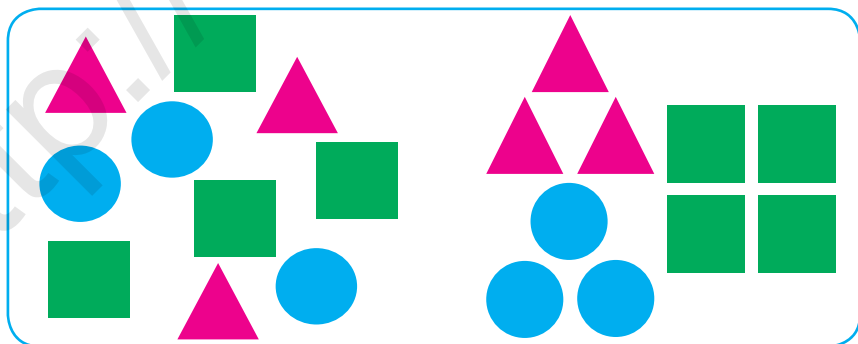

-  4.  $30 + 13$   $65 - 60$   $50 + 25$   
 $42 - 40$   $44 + 30$   $32 - 30$   
 $43 + 10$   $57 - 50$   $28 + 20$







11. Жеміс өнімдерін түрлеріне қарай бірнеше топтарға ажырат.



12. Балалар лагерінде 58 ұл бала, одан 28 кем қыз бала демалды. Лагерде барлығы неше оқушы дем алған?



13. Мысалдардың шешімін түсіндір:

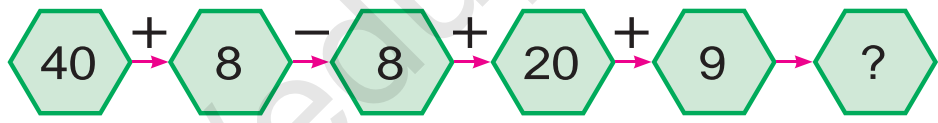

14. Сызбада қандай фигураларды көріп тұрсың. Оларды жеке-жеке дәптерлеріңе сыз және аттарын айт.



15. Мысалдарды түсіндіріп шеш:



- |        |        |        |        |
|--------|--------|--------|--------|
| 20 + 7 | 84 - 4 | 60 + 7 | 93 - 3 |
| 48 - 8 | 50 + 6 | 32 - 2 | 30 + 5 |

# Үлгі бойынша тізбектілікті жалғастыру



1. Мысалдарды түсіндіріп шеш:

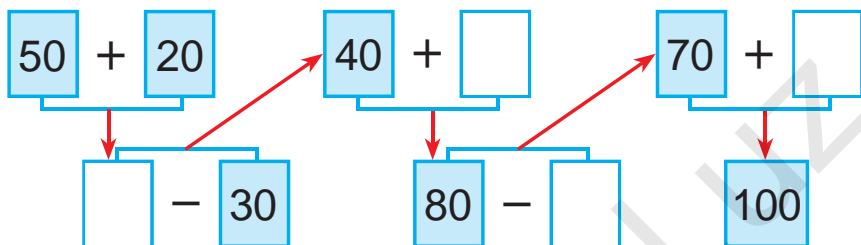

2. Бағбан бір түп құрмадан 30 кг, екінші түп құрмадан болса 9 кг артық өнім жинап алды. Бағбан екі түп құрмадан неше килограмм құрма жинап алды?



3.

$40 + \bigcirc = 45$	$58 - \bigcirc = 50$
$\bigcirc - 6 = 30$	$60 + \bigcirc = 62$
$20 + \bigcirc = 27$	$79 - \bigcirc = 70$

4. Кім мәреге тез жетеді?



$30 + 25 \rightarrow 55 - 5 \rightarrow 50 + 10 \rightarrow 60 + 40$



$40 + 25 \rightarrow 65 - 10 \rightarrow 55 + 20 \rightarrow 75 + 25$



5. Мысалдарды түсіндіріп шеш:

$50 + 5$	$17 - 10$	$50 + 20$	$70 - 40$
$46 - 6$	$40 + 12$	$80 - 50$	$30 + 30$
$20 + 9$	$90 - 70$	$20 + 20$	$80 - 50$







6. Үлгі бойынша орында:

$$20 = 10 + 10$$

$$30 = 20 + \square\square$$

$$40 = 30 + \square\square$$

$$50 = 30 + \square\square$$

$$60 = 50 + \square\square$$

$$70 = 40 + \square\square$$

$$80 = 50 + \square\square$$

$$90 = 70 + \square\square$$

$$100 = 50 + \square\square$$

7. «Билимдон» журналына 25, «Ғунча» журналына болса одан 4 артық оқушы жазылды. Әр екі журналға қанша оқушы жазылды?



8. Мысалдарды түсіндіріп шеш.

Diagram illustrating the relationship between addition and subtraction using helicopter icons:

- Top row:  $42 + 8$  (blue helicopter) ←  $72 - 30$  (red helicopter)
- Bottom row:  $50 + 14$  (green helicopter) →  $64 - 32$  (red helicopter)
- Right side:  $32 + 40$  (blue helicopter)



9. Фигураларды дәптеріңе сыз және олардың қабырғаларын сызғыш көмегінде өлше.



10.  $20 + 8 \square 35$

$$39 - 9 \square 27$$

$$50 + 2 \square 72$$

$$45 - 5 \square 40$$

$$70 + 3 \square 62$$

$$88 - 8 \square 90$$

$$50 + 8 \square 74$$

$$66 - 6 \square 60$$

$$90 + 2 \square 99$$



# Санды өрнектер. Кестелер. Геометриялық фигуралар

## Санды өрнектер

-  1.  $25+3$ ,  $25-3$  – бұлар санды өрнектер немесе **өрнектер** деп аталады.

**Өрнекте көрсетілген амалдардың нәтижесі өрнектің құны деп аталады.**

$25+3=28$  25 пен 3 санының жиынтығы 28-ге тең.

$25+3$  **өрнек**, 28 **өрнектің құны**.

-  2. Төмендегі өрнектерді есепте:

$21+8$

$34+4$

$43+5$

$49-40$

$87-7$

$55-5$

-  3. Кесте негізінде есеп құрастыр және оны шеш, пайда болған өрнектерді түсіндір:

Бар еді	Жұмсалды	Қалды
 9 кг және 7 кг	6 кг	? кг

  $9+7$ ,  $9-7$ ,  $(9+7)-6$  өрнектерінің мәнін есептеп, есептің шешімін тап?

 4.  $37+2$

$48-3$

$46+4$

$69-5$

$37+20$

$48+30$

$46+40$

$69-50$



5. Батырда 28 жаңғақ бар. Інісіндегі жаңғақтар ағасыныкінен 8 жаңғақ кем. Ағалы-ініде барлығы болып қанша жаңғақ бар?

Төмендегі өрнектер нені білдіреді?

$$28 - 8$$

$$28 + (28 - 8)$$



6.

$$42 + \bigcirc = 72$$

$$38 - \bigcirc = 30$$

$$\bigcirc - 2 = 60$$

$$60 + \bigcirc = 90$$

$$30 + \bigcirc = 60$$

$$25 - 20 = \bigcirc$$

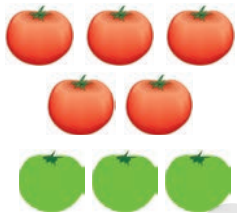
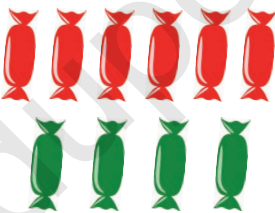
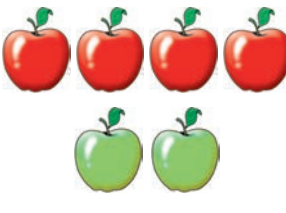

7. Суретке сай өрнек құрастыр және оны шеш:

 $5 + 3$	 <input type="text"/>	 <input type="text"/>
--	---	--



8. Өрнектерді есепте:

26 және 4, 38 және 20 сандарының жиынтығы;

54 және 4, 67 және 20 сандарының айырмасы.



9. Амал белгілерін теңдектің дұрыс болатындай етіп қой:

$$50 \square 2 = 52$$

$$75 \square 5 = 70$$

$$30 \square 4 = 34$$

$$29 \square 9 = 20$$

$$60 \square 8 = 68$$

$$83 \square 3 = 80$$

$$30 \square 8 = 38$$

$$57 \square 7 = 50$$

$$40 \square 6 = 46$$





10. Өрнектердің мәнін тап.

$47 + 2$

$58 + 20$

$16 + 3$

$69 - 30$

$45 - 10$

$38 - 8$

11. Кестеден жауабы бірдей болған мысалдарды тап:

$99 - 9$	$87 - 7$	$40 + 10$	$90 - 30$
$56 - 6$	$89 + 1$	$45 - 5$	$20 + 20$
$79 + 1$	$75 - 5$	$30 + 30$	$80 - 10$

12. Жаңа құрылған ғимараттың бірінші қабатында 24, ал екінші қабатында болса 26 бөлме бар. Ғимараттың екінші қабатында біріншісіне қарағанда қанша көп бөлме бар?



13. Есеп құрастыр және оны шеш:

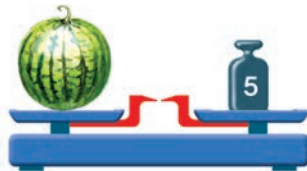

Асқабактың массасы неше килограмм?  
Қарбыздың массасы-ше?

14. Екі көрші қосылғышты қосындымен алмастырып, қолайлы тәсілмен шеш:

$50 + 20 + 8$

$90 - 40 + 7$

$30 + 30 - 4$



15. Сандарды таңба қосындылары жынтығы көрінісінде өрнекте.

$45 = 40 + 5$

$63 = 60 + \square$

$29 = 20 + \square$

$59 = 50 + \square$

$77 = 70 + \square$

$38 = 30 + \square$

$87 = 80 + \square$

$26 = 20 + \square$

$94 = 90 + \square$



## Құрамды есептер



1. Велосипедшілер жарысына Кәрім белгіленген жерге 30 минутта, Сәлім болса 35 минутта жетіп келді. Кәрім Сәлімнен неше минут алдын жетіп келген. Сәлім Кәрімнен неше минут кейін жетіп келген?

2.  $(70 + 20) + 7$

$(80 - 40) + 9$

$(90 - 50) + 5$

$(30 + 30) + 8$



3. Сурет негізінде төмендегі тәсілде шешілетін есептер құрастыр.

$10\text{ л} + 5\text{ л}$ ,  $10\text{ л} + 2\text{ л}$ ,  $5\text{ л} + 2\text{ л}$ ,  $10\text{ л} - 5\text{ л}$ .



10 л



5 л



2 л



4. Төмендегі шарттарға қарап есептер құрастырып шеш:

1) бар еді — 80 қаз

тағы әкелінді — 15 қаз

? дана

2) бар еді — ? дана

кейін әкелінді — 15 қаз

95 дана

3) бар еді — 80 қаз

әкелінді — ? дана

95 дана



5.  $90 + 2$

$75 - 5$

$80 + 5$

$96 - 6$

$88 - 8$

$60 + 4$

$23 - 3$

$50 + 7$

$40 + 3$

$57 - 7$

$59 + 1$

$69 - 9$





6. Қызанақ салынған жәшіктің массасы 20 кг, ал сәбіз салынған жәшік одан 4 кг ауыр. Сәбіз салынған жәшіктің массасы неше килограмм?



7. Мекен жайға жетіп бару үшін қайсы жол дұрыс?

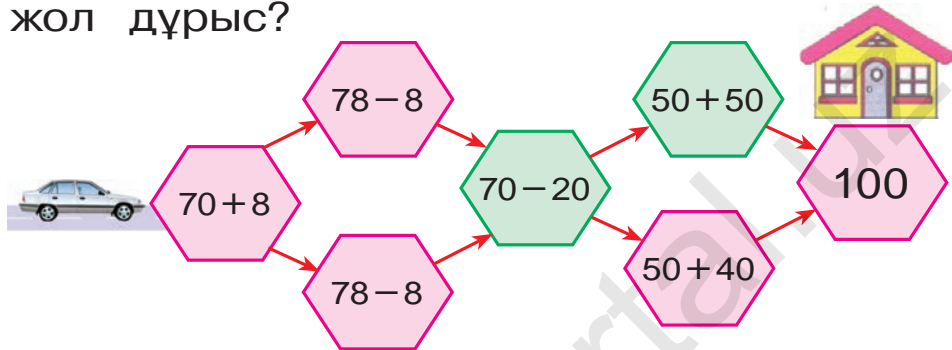

8. Қысқа жазу бойынша есеп құрастыр және оны шеш:

Шахмат – 20  
 Шашка – ?, 5-еу артық

← ? дана



9. Мысалдарды түсіндіріп шеш:

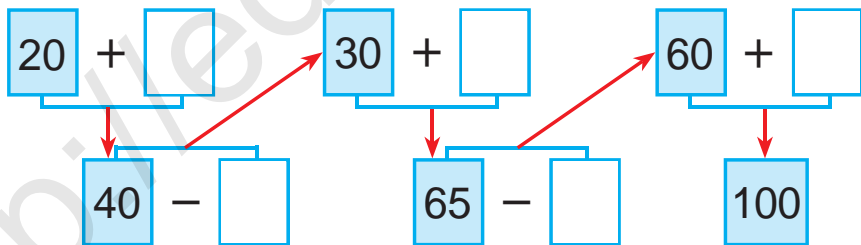

10. Сада ағашының ұзындығы 9 м, терек сададан 3 м биік. Терек неше метр?



11. Теңдіктер дұрыс болатындай сан қой:

$20 + \square = 28$		$59 - \square = 50$		$80 + \square = 88$
$28 - \square = 20$		$50 + \square = 59$		$88 - \square = 80$





12. Бір бағанға сандардың қосындысын, екінші бағанға сандардың айырмасын жаз және оны шеш:

$48 - 20$

$45 + 40$

$55 - 20$

$35 + 10$

$34 + 20$

$99 - 60$

$46 + 30$

$67 - 10$



13. Мысалдардың жауабын тап:



$60 + 12$

$97 - 7$

$58 - 40$

$20 + 14$

$37 - 5$



14. Бір орамда 47 м мата бар еді. Балаларға көйлек тігу үшін 17 м, ал ересектерге көйлек тігу үшін 10 м мата қырқып алынды? Орамда неше метр мата қалды?



15. Мысалдарды түсіндіріп шеш:

$$\begin{array}{l}
 35 + 30 = \boxed{\phantom{00}} \quad 65 + 20 = \boxed{\phantom{00}} \quad 85 - 50 = \boxed{\phantom{00}} \\
 55 - 20 = \boxed{\phantom{00}} \quad 45 + 10 = \boxed{\phantom{00}} \quad 35 + 30 = \boxed{\phantom{00}} \\
 65 - 10 = \boxed{\phantom{00}}
 \end{array}$$



16.  $20 + 9 \square 30$   
 $45 - 5 \square 40$

$36 - 6 \square 29$   
 $50 + 8 \square 68$

$80 + 4 \square 79$   
 $79 - 9 \square 70$





# Бөлшектерден бүтінді, бүтіннен бөлшектерді құрау



1. Қандай фигуралар пайда болды?  
Атын айт.

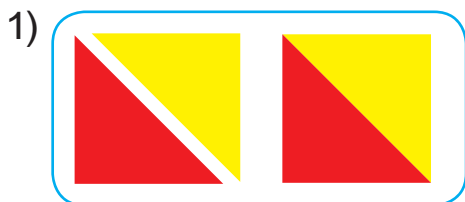

2. Бір орамда 49 м сым бар еді. Бірінші жұмыс күнінде 17 м сым қырқып алынды. Орамда қанша метр сым қалған?



3. Ойла, ізде, тап!

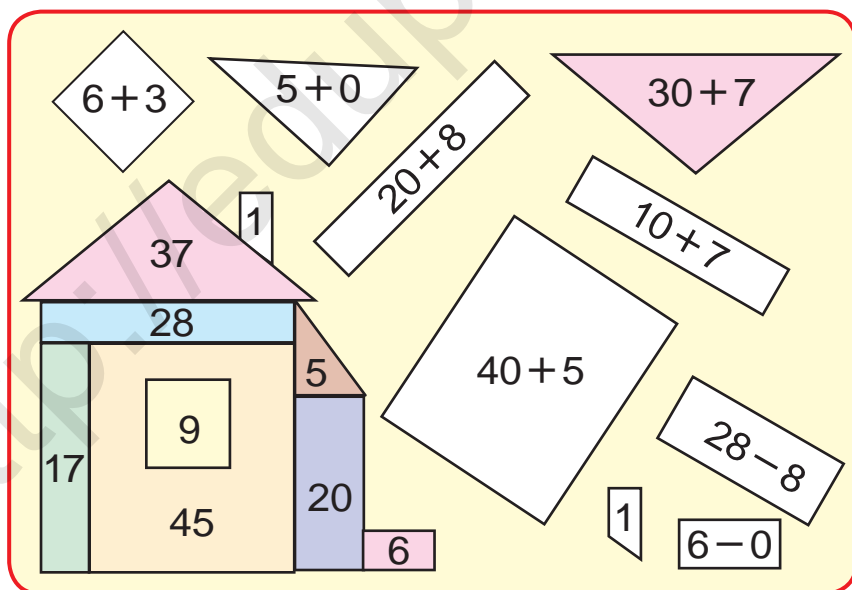

4. Мысалдарды шеш:

$90 - 30$

$60 - 20$

$60 - 40$

$40 - 10$

$70 - 10$

$70 - 50$

$60 - 30$

$50 - 30$





5. Балалар бақшасына 30 кг пияз және одан 27 кг артық картоп алып келінді. Төмендегі өрнектер нені білдіреді?

$$30 + 27$$

$$30 + (30 + 27)$$



6. Ойла, ізде, тап!

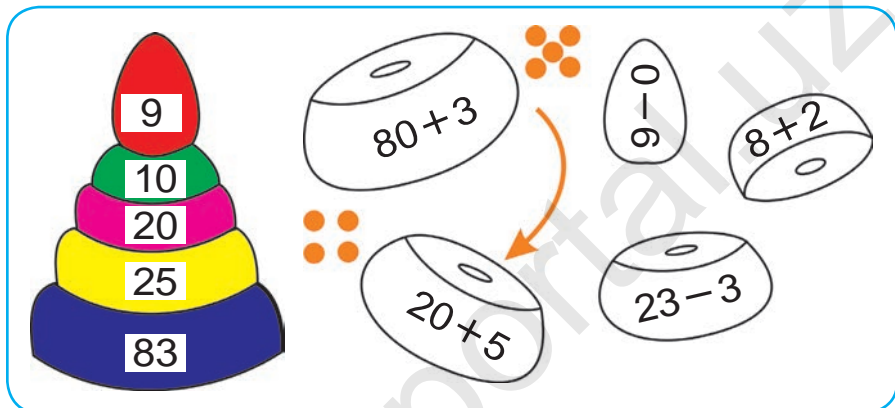

7. Құстар үшін балалар екі күнде 28 үйшік жасады. Олар 8 үйді іліп қойды. Балалар және неше үйшікті ілулері керек?



8. Қарбыз неше бөлікке бөлінген?



$$9. \quad 28 + 10$$

$$40 + 38$$

$$56 - 20$$

$$37 - 10$$

$$50 + 14$$

$$54 + 10$$





10. Дүкенде 59 теледидар бар еді. Түске дейін 20, түстен соң 9 теледидар сатылды. Дүкенде сатылатын және қанша теледидар қалды?

11. Фигуралар негізінде берілген мысалдарды шеш. Сол фигуралардан пайда болған формаларды дәптеріңе сыз және оның бөліктерінің ішіне сәйкес жауаптарды жаз:

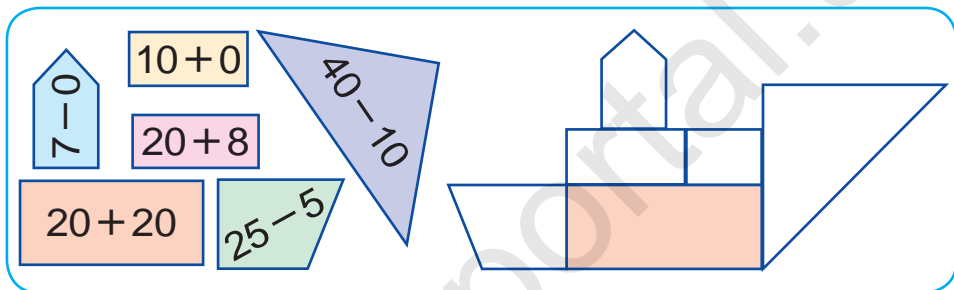

12. 1) Ойлаған санға 60-ты қосып, 98 пайда болды. Қандай сан ойланған?

2) Ойланған санды 24-ке азайтып, 30 пайда болды. Қандай сан ойланған?



13.  $29 - 9$                        $20 + 20$                        $57 - 10$   
 $30 + 7$                          $75 - 10$                        $46 + 10$

14. Гүл негізінде берілген мысалдарды шеш:

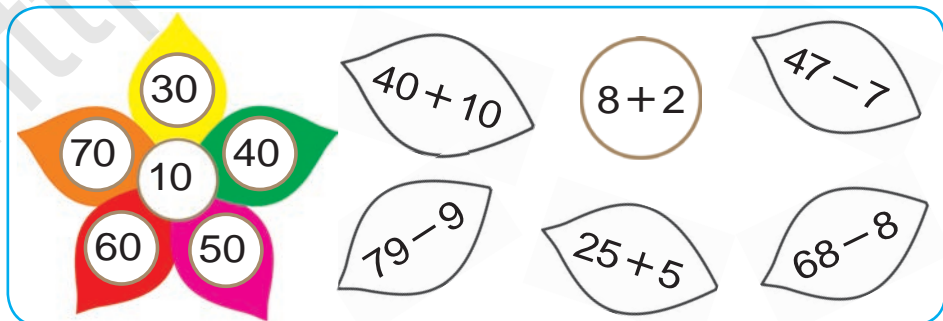

15.  $30 + 7$

$54 - 40$

$65 + 10$



# Кесте. Жай кестелерді қосу



1. Кесте негізінде мысалдар құрастыр және оны шеш:

+	1	2	3	4	5	6	7	8	9	10
1	2	3	4	5	6	7	8	9	10	11
2	3	4	5	6	7	8	9	10	11	12
3	4	5	6	7	8	9	10	11	12	13
4	5	6	7	8	9	10	11	12	13	14
5	6	7	8	9	10	11	12	13	14	15
6	7	8	9	10	11	12	13	14	15	16
7	8	9	10	11	12	13	14	15	16	17
8	9	10	11	12	13	14	15	16	17	18
9	10	11	12	13	14	15	16	17	18	19
10	11	12	13	14	15	16	17	18	19	20

$1 + 1 = 2$

$2 + \square = 4$

$3 + \square = 6$

$4 + \square = 8$

$5 + \square = 10$

$6 + \square = 12$

$7 + \square = 14$

$8 + \square = 16$

$9 + \square = 18$

$10 + \square\square = 20$

2. Бірінші орамда 60 м, екінші орамда одан 42 м кем мата бар. Екі орамда неше метр мата бар?



3.  $92 \square 90$  |  $52 \square 72$  |  $40 \square 40$  |  $50 \square 42$



4. Есеп құрастыр және оны шеш:

Бар еді — 76 кг қызанақ

Тұздалды — 34 кг қызанақ

Қалды — ? кг қызанақ



5.  $60 + 40$                        $50 + 50$                        $62 + 30$   
 $80 + 20$                        $83 + 10$                        $50 + 46$   
 $56 + 40$                        $70 + 20$                        $70 + 30$





6. Кестеден пайдаланып, мысалдардың мәнін тап:

+	1	2	3	4
2				
4				
5				
6				

-	1	2	3	4
1	0			
2	1			
3	2	1		
4				



7. Бақшаға 60 түп көшет отырғызылған. Олардан 20 түбі алма, 30 түбі алша, қалғандары жиде көшеті. Бақшаға неше түп жиде көшеті отырғызылған?

8. 1) 38, 42, 49, 50, 67, 83, 97 сандарынан алдын келген сандарды жаз;

2) 9, 19, 29, 59, 79, 99 сандарынан кейін келген сандарды жаз.



9. Санақ таяқшалардан қанша квадрат пайда болған? Санақ таяқшаларынан біреуін алғанда, нәтижеде төрт квадрат қалсын.

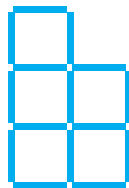

$10. 56 - \square = 50$

$30 + \square = 34$

$49 - \square = 40$

$58 - \square = 50$

$80 + \square = 85$

$43 - \square = 40$

$97 - \square = 90$

$70 + \square = 79$

$53 - \square = 50$







11. Бір орамда 50 м мата бар еді. Одан 20 м мата қырқып алынды. Орамда неше метр мата қалды?



# Берілген мәліметтер негізінде кесте толтыру

1.

 +  = 100									
	99		98		97		96		95
		50		60		40		30	

2. Ыдыста 40 л жанармай бар еді. Бірінші машинаға 25 л, екіншісіне 10 л жанармай құйылғаннан соң ыдыста қанша литр жанармай қалды?

3. Сурет бойынша есеп құрастыр және оны шеш:



30 кг

және



27 кг

өрік бар еді.

Жұмсалды – 20 кг

Қалды – ? кг

4. Кесте негізінде берілген мысалдарды шеш.

Азайғыш	90	50	80	40	70	30	60
Азайтқыш	20	30	40	20	10	20	50
Айырма							

5.  $55 + 20$  |  $84 - 14$  |  $83 + 7$  |  $45 - 40$   
 $65 + 10$  |  $95 - 30$  |  $24 + 3$  |  $24 - 10$



1. Мысалдардың шешімін түсіндір:

$$35 + 42 = 30 + 5 + 40 + 2 = 70 + 7 = 77$$

$$24 + 31 = 20 + 4 + 30 + 1 = 50 + 5 = 55$$

**Бір таңбалы сандарды қосуда ондықтар ондықтарға, бірліктер бірліктерге қосылады.**

2. Мысалдардың шешімін түсіндір:

$$38 - 17 = \square \square$$

$$38 - 17 = \square \square$$

$$30 - 10 = 20$$

$$38 - 10 = 28$$

$$8 - 7 = 1$$

$$28 - 7 = 21$$

$$20 + 1 = 21$$

$$38 - 17 = 21$$

$$38 - 17 = 21$$

**Екі таңбалы сандарды айыруда ондықтар ондықтардан, бірліктер бірліктерден айырылады.**

3. Кестеден жауабы бірдей болған мысалдарды тап:

$38 + 12$	$57 - 22$	$45 + 45$	$53 - 50$
$99 - 9$	$18 + 12$	$56 - 16$	$48 + 30$
$20 + 20$	$69 - 2$	$80 + 17$	$98 - 20$



4. 30 және 20 сандарының қосындысы 50-ге тең. Қосынды бірінші қосылғыштан қанша артық. Екінші қосылғыш ше?



5.  $34 + 13$

$62 + 16$

$54 + 25$

$42 + 25$

$44 + 33$

$32 + 24$





# 100 санынан бір таңбалы санды айыру

$$100 - 8 = \square \square$$

1. Шешімдерін түсіндір:

$$100 - 8 = \square \square$$

$$10 + 90 = 100$$

$$10 - 8 = 2$$

$$90 + 2 = 92$$

$$100 - 8 = 92$$

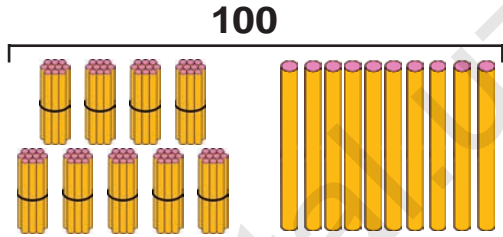

9 ондық      1 ондық

100 санынан 8-ді азайту керек. 100 – бұл 10 ондық. Бір ондықты аламыз. Бір ондықтан 8 бірлікті айырсақ, 2 бірлік қалады. 9 ондық пен 2 бірлік 92 болады.

2. Шешімін түсіндіріп, жауаптарын тап:

$$100 - 4 \quad | \quad 100 - 7 \quad | \quad 100 - 2 \quad | \quad 100 - 5$$

3. Дүкенде 100 люстра бар еді. Түске дейін 9-ы сатылды. Дүкенде сатылатын қанша люстра қалды?

4. Есепте:

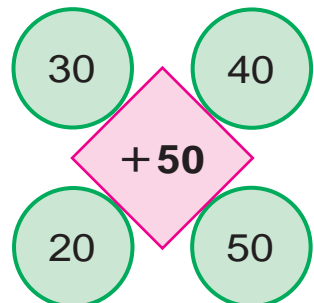
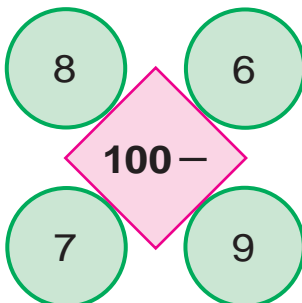



# 100 санынан екі таңбалы санды айыру

$$100 - 72 = \square\square$$



1. Шешімін түсіңдір:

$$100 - 72 = \square\square$$

$$10 + 90 = 100$$

$$10 - 2 = 8$$

$$90 - 70 = 20$$

$$20 + 8 = 28$$

$$100 - 72 = 28$$

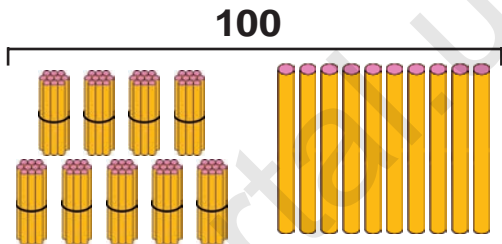

9 ондық 1 ондық

100 санынан 72-ні айыру керек. 100-бұл 10 ондық. Бір ондықты аламыз. Бір ондықтан 2-ні азайтсақ, 8 қалады. Бізде 9 ондық қалған еді. 9 ондық – 7 ондық = 2 ондық 2 ондық және 8 бірлік 28 болады.



2. Шешімін түсіндіріп, жауабын тап:

$$100 - 36$$

$$100 - 57$$

$$100 - 62$$

$$100 - 42$$

$$100 - 24$$

$$100 - 56$$

3. Дүкенге 100 дана нан келтірілді. Түске дейін 82-сі сатылды. Тағы сатылатын неше нан қалды?



4. Салыстыр:

$$100 \square 90$$

$$29 \square 92$$

$$49 \square 49$$

$$65 \square 56$$



## Екінші қосылғышты табу

1. Сурет негізінде есеп құрастыр және оны шеш:



12 кг



10 кг



? кг

30 кг

2. Үш ыдыста барлығы болып 95 л жанармай бар. Бірінші ыдыста 40 л, екінші ыдыста 35 л жанармай болса, үшінші ыдыста неше литр жанармай бар?

3. Қосылғыш	26	42	44	51	62	12	45	40
Қосылғыш	54	20	46	28	24	78	25	30
Қосынды								

4. Қожалықтан диірменге 50 қап бидай, одан 8 қап кем арпа алып келінді. Диірменге барлығы болып неше қап дән алып келінген?

5.  $80 + \bigcirc = 90$        $49 - \bigcirc = 24$

$\bigcirc - 33 = 25$        $\bigcirc + 20 = 58$

$57 + \bigcirc = 67$        $60 - \bigcirc = 20$



6. Тауықтарды бағу үшін бір аптада 28 кг дән, ал қаздарды бағу үшін одан 11 кг кем дән жұмсалды. Тауық және қаздарды бағу үшін неше килограмм дән жұмсалады?

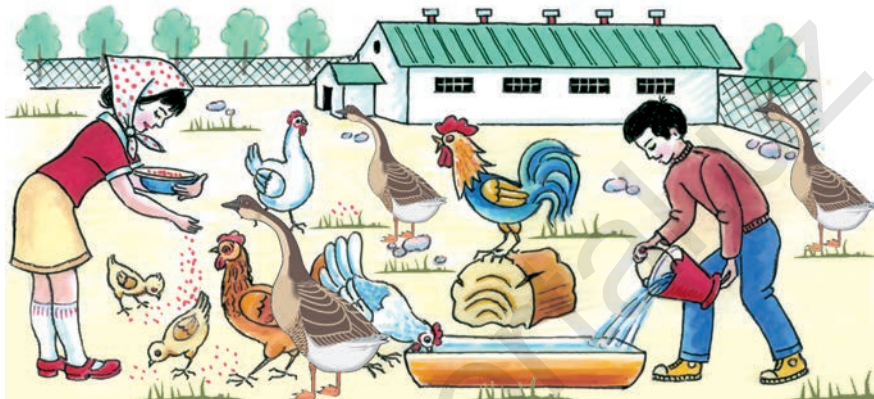

7. Сурет негізінде есеп құрастырып және оны шеш:



8. Жақшаларды қойғанда, нәтиже берілген санға тең болсын:

$$80 - 20 + 7 = 67$$

$$30 - 7 + 3 = 20$$



9.  $46 + 43$

$95 - 35$

$100 - 52$

$71 + 29$

$68 - 24$

$100 - 37$

$20 + 45$

$86 + 13$

$100 - 62$





10. Сурет бойынша есеп құрастыр және оны шеш:

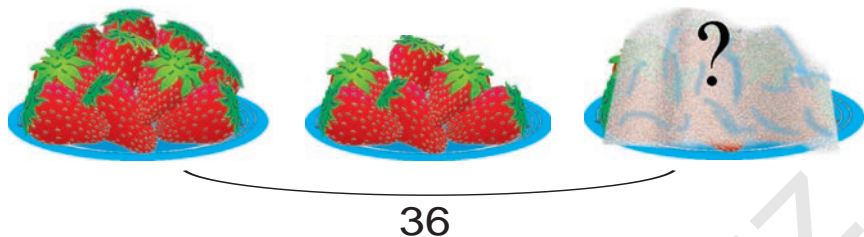

11. Үш санның қосындысы 78. Бірінші сан 32, екінші сан 26. Үшінші санды табыңдар.



12.  $28 + \bigcirc = 38$        $\bigcirc - 20 = 48$   
 $\bigcirc - 6 = 50$        $25 + \bigcirc = 75$   
 $57 + \bigcirc = 67$        $\bigcirc - 30 = 38$



13. Кесте негізінде есеп құрастыр және оны шеш:

Бар еді	Келтірілді	Болды
		
40 қап сәбіз	Және 40 қап сәбіз	? қап сәбіз



14. Қолайлы тәсілмен есепте:

$67 + 13$

$25 + 25$

$25 + 45$

$28 + 62$

$83 + 17$

$86 + 14$



# Тізбектілікті жалғастыру



1. Мысалдарды үлгі бойынша шеш:

$$100 - 43 = (100 - 40) - 3 = 60 - 3 = 57$$



$100 - 65$

$100 - 52$

$100 - 78$

$100 - 36$

$100 - 25$

$100 - 47$

2. Қоймада 90 қап ұн бар еді. Түске шейін 30 қап, түстен кейін 32 қап ұн сатылды. Қоймада неше қап ұн қалды?



3. Мысалдарды түсіндіріп шеш:

$$40 + 28 = \square \square \quad 68 + 30 = \square \square \quad 98 - 40 = \square \square$$

$$79 - 39 = \square \square \quad 54 + 25 = \square \square \quad 58 + 12 = \square \square$$

$$70 - 16 = \square \square$$



4. Фигураларды дәптеріңе сыз. Ұқсас фигураларды сыз. Ұқсас фигураларды бірдей реңге боя:

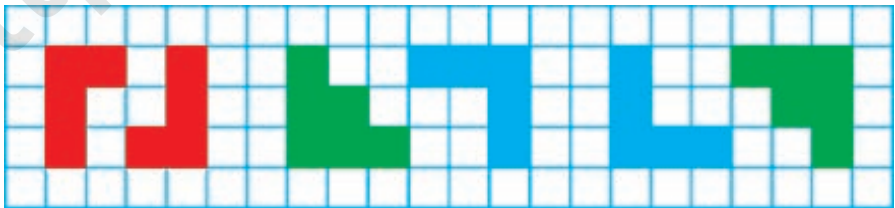

5.	$69 + 21$	$27 + 20$	$66 - 26$	$50 + 36$
	$57 + 43$	$39 - 29$	$72 - 32$	$96 - 46$



6. Мысалдарды түсіндіріп шеш:

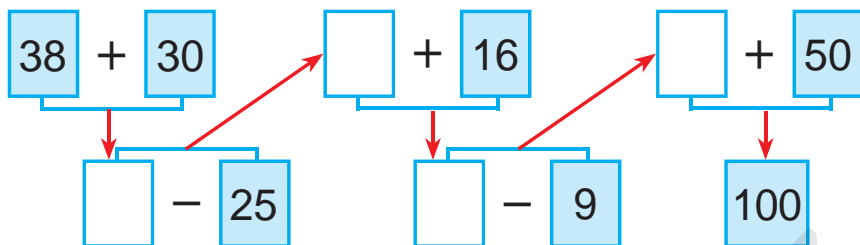

7. Шахмат-шашка үйірмесіне 32 ұл бала және олардан 15 артық қыз бала қатысты. Үйірмеге неше қыз қатысты? (Есепке сұрақ қойғанда, ол екі амалмен шешілетін болсын.)



8. Мысалдардың жауабын тап:



9. Берілген сурет негізінде есеп құрастыр және оны шеш:



және



26 кг

24 кг

Жұмсалды – 30 кг

Қалды – ? кг

10.  $26 + 14$  |  $52 - 20$  |  $54 + 16$  |  $39 - 19$   
 $47 - 17$  |  $38 + 30$  |  $68 - 28$  |  $25 + 15$

 11. Мысалдарды үлгі бойынша орында:

$$\underline{21 + 21 = 42}$$

$$22 + \square\square = 44$$

$$24 + \square\square = 48$$

$$32 + \square\square = 64$$

$$33 + \square\square = 66$$

$$34 + \square\square = 68$$

$$42 + \square\square = 84$$

$$43 + \square\square = 86$$

$$44 + \square\square = 88$$

 12. Шелекте 28 кг алша бар еді. 20 кг алшадан варенье даярланды. Шелекте неше килограмм алша қалды?

13. Реңдерге қарап, топтарға бөлінген түрде, мысалдарды шеш:

$46 + 4$	$58 - 55$	$32 + 28$	$58 - 27$
$74 + 26$	$64 + 30$	$60 - 4$	$47 + 2$
$60 - 42$	$42 + 25$	$50 + 36$	$25 - 15$

 14. «Матиз» автокөлігінің багінде 39 л, «Нексия» автокөлігі багінде болса одан 16 л артық жанармай бар. Екінші автокөліктің багінде неше литр жанармай бар?



15. 18 бала ойнап жүрген еді. Алғаш 5 қыз бала, кейін 3 ұл бала кетті. Ойында неше бала қалды?

$$16. \quad 26 + 14$$

$$47 - 17$$

$$52 - 20$$

$$38 + 30$$

$$54 + 16$$

$$68 - 28$$

$$39 - 19$$

$$25 + 15$$



## Логикалық анықтамалар: «барлығы», «кейбіреулері», «...дан тыс барлығы»...



1. Суретте берілген заттардың барлығының атын айт. Оларды бір сөзбен не деп айту мүмкін?



2. Бір қойдан 7 кг, басқасынан одан 3 кг артық жүн қырқып алынды. Екі қойдан барлығы болып неше килограмм жүн қырқып алынған?

3. Өрнектердің мәнін тап. Сандар орналасуындағы өзіне тәндікті түсіндір.

$53 + 41$

$62 + 21$

$54 + 45$

$32 + 26$

$35 + 14$

$26 + 12$

$45 + 54$

$23 + 62$



4. Фигуралардың аттарын айтып бер:

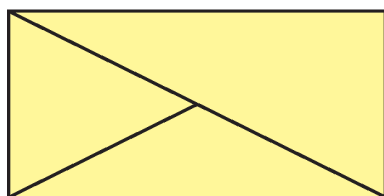
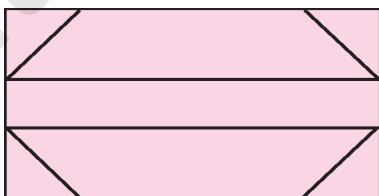

$(30 + 20) - 10$

$(90 - 40) + 30$

$(80 - 50) + 20$

$(20 + 20) - 20$



# «әр қандай», «өз еркімен», «....лардан бірі», « барлығынан бірі» және олардың мағыналары

-  1. Суретте бейнеленген заттардың баршасының атын айт. Оларды бір сөзбен не деп айту мүмкін?



Сен де сондай өз еркімен жинақ түз.

-  2. Мектеп спорт үйірмесі үшін 40 шахмат және шашка келтірілді. Олардан 20-сы шахмат болса, неше шашка келтірілген?

3. $86 - 23$	$97 - 43$	$67 - 45$	$58 - 26$
$68 - 32$	$79 - 34$	$76 - 54$	$85 - 62$

4. Есеп құрастыр және оны шеш:

1-машинада – 54 қап пияз  
2-машинада – 46 қап пияз ) ?, қап

-  5. Қандай 4 бірдей қосылғыштардың қосындысы 100 болады?

6. $80 \text{ см} - 50 \text{ см}$	$40 \text{ дм} + 30 \text{ дм}$
$30 \text{ дм} + 30 \text{ дм}$	$90 \text{ см} - 70 \text{ см}$





7. Баршасының атын айт және оларды бір сөзбен не деп айту мүмкін?



8. Асханаға 45 л сүт келтірілді. Сүттің бір бөлігі істетілгеннен соң 30 л сүт қалды. Неше литр сүт істетілген?

9. Реңдерге қарап, топтарға бөлінген мысалдарды шеш:

$37 + 3$	$48 - 40$	$60 + 23$	$58 - 30$
$67 - 20$	$71 + 10$	$90 - 30$	$45 + 20$
$83 + 10$	$78 - 20$	$88 + 10$	$98 - 30$

10. 1) 2, 7, 9 цифралары көмегінде 9 екі таңбалы санды жазу мүмкін: 22, 27, 29, 72, 77, 79, 92, 97, 99;

2) 5, 1, 4 цифралары көмегінде пайда болатын барлық екі таңбалы сандарды жаз.



11.  $34 + 6$  |  $21 + 9$  |  $35 + 5$  |  $15 + 5$   
 $34 + 26$  |  $29 + 21$  |  $35 + 15$  |  $75 + 15$



# Берілген ұзындықтағы кесіндіні жасау. Ұзындық пен арақашықтықтарды өлшеу және шамалау



1. Сызғыш жәрдемінде әрбір кесіндінің ұзындығын сантиметр және миллиметрлерде анықта:



2. Жолақтың ұзындығы 30 м. Сайд пен Умид жолақтың екі басынан бір-біріне қарап жүрді. Олар ұшырасқанға дейін Сайд 16 м жүрді. Умид ұшырасқанға дейін қанша жүрген?

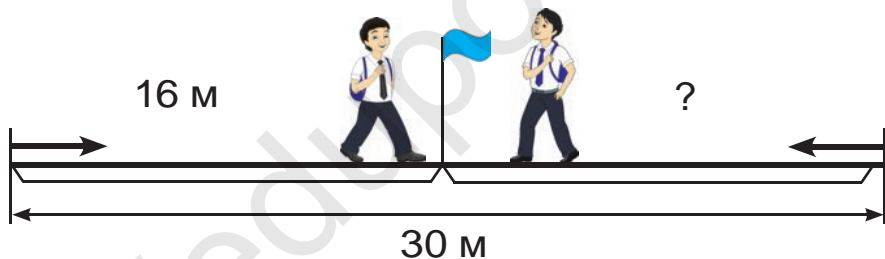

3.	$54 + 46$	$74 + 26$	$83 + 17$	$62 + 38$
	$58 + 42$	$71 + 29$	$87 + 13$	$65 + 35$

4. Бірініші кесіндінің ұзындығы 5 см, екінші кесінді одан 4 см ұзын, үшінші кесінді бірінші кесіндіден 6 см қысқа, үшінші кесіндінің ұзындығын тап.

5. Екі көрші қосылғыштарды қосындымен алмастырып, ыңғайлы тәсілмен шеш:

$50 + 20 + 8$	$90 - 40 + 7$	$38 + 30 - 4$
---------------	---------------	---------------

6.	$30 + (6 + 3)$	$40 + (9 - 2)$	$50 + (6 + 2)$
	$80 + (7 + 2)$	$50 + (8 - 4)$	$70 + (9 - 5)$





7. Бұл кесіндінің ұзындығын салыстыр:

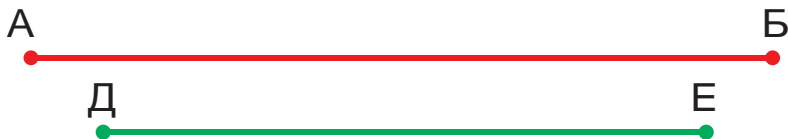

8. Гүлнара мен Дилноза жаяу жолдың екі басынан бір-бірлеріне қарап жүрді. Олар кездескенше Гүлнара 42 м, Дилноза одан 4 м артық жүрді. Жаяу жолдың ұзындығы қанша?

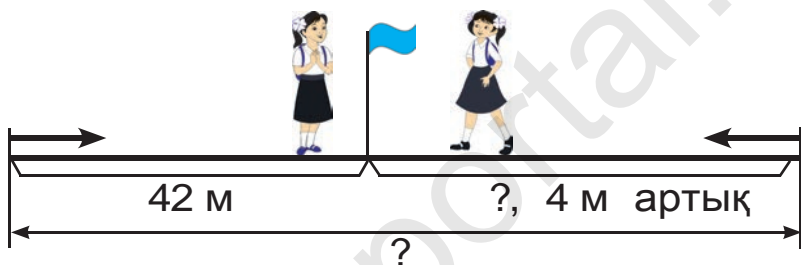

9.  $54 - 46$  |  $62 + 44$  |  $87 - 17$  |  $83 - 63$   
 $85 + 15$  |  $92 - 22$  |  $67 + 23$  |  $75 + 15$



10. Жауабы 100 шығуы үшін қайсы тараптан жүру керек?

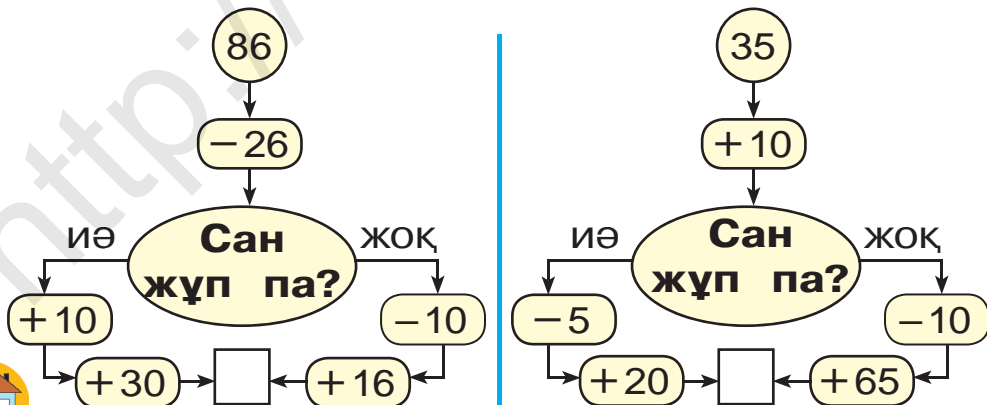

11. Асқабақ 9 кг, қауын одан 3 кг кем. Асқабақтың массасы неше килограмм?



12. Бірніші кесіндінің ұзындығы 7 см, екінші кесінді одан 4 см ұзын, үшінші кесіндінің ұзындығы екінші кесіндінің ұзындығынан 2 см қысқа. Үшінші кесіндінің ұзындығын тап:

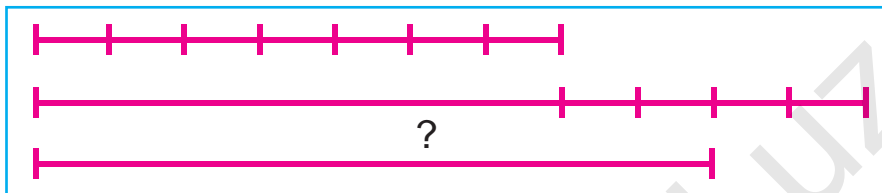

13. Үйден нан дүкеніне жолақ арқылы немесе көпірден өтіп бару мүмкін. Қайсы жол қысқа және қанша қысқа?

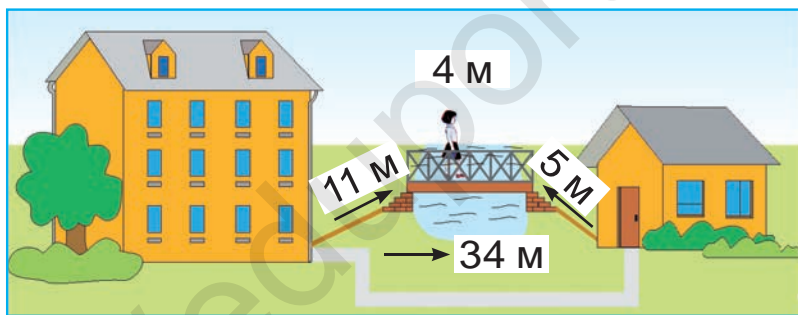

14. 39 кг жеміс бар еді. Варенье дайындау үшін 20 кг, ал шербат дайындау үшін 9 кг жеміс жұмсалды. Неше килограмм жеміс артып қалды?



15. Қандай фигураларды көріп тұрсың?

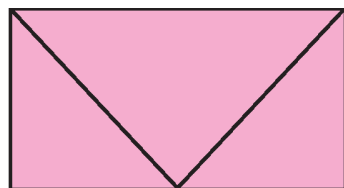
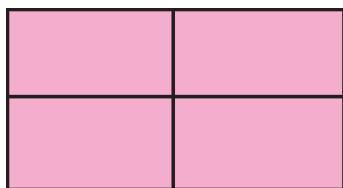

16.  $98 - 20$

$94 - 93$

$67 - 32$

$76 + 23$

$100 - 62$

$72 + 23$



# Түрлі фигуралар жасау. Бөліктерден формалар мен фигуралар құрастыру



1. Бөліктерден қандай фигура пайда болды?

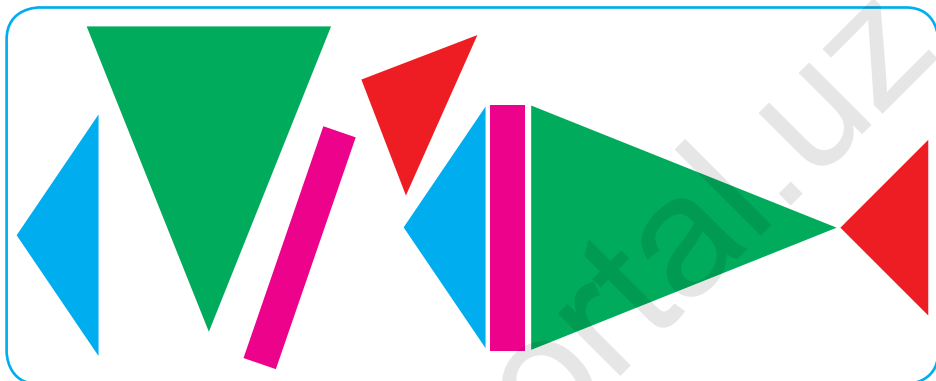

2. Дүкенде 32 кг сарымай бар еді. Және 17 кг сарымай келтірілді. Бір күнде 29 кг сарымай сатылды. Дүкенде қанша сарымай қалды?

3. Квадрат бөліктерінен осындай формалар жаса:

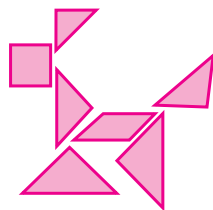
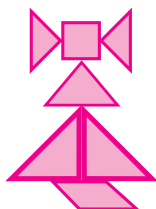
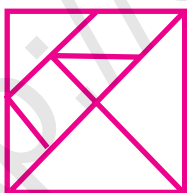

4. Мектеп бақшасына 26 түп раушангул және 24 түп райхан алып келінді. Мектеп бақшасына барлығы болып неше түп гүл алып келінген?



5.	$21 + 21$	$32 + 32$	$14 + 14$
	$24 + 24$	$42 + 42$	$33 + 33$
	$44 + 44$	$13 + 13$	$22 + 22$





6. Бөліктерден қандай фигура пайда болды?

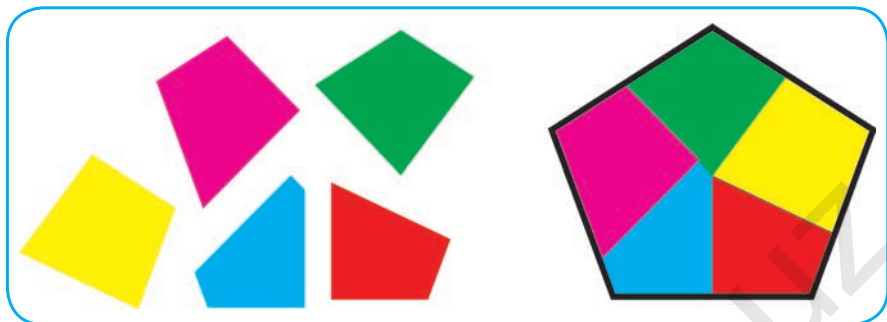

7. 1) Бірінші қорапта 26, екінші қорапта болса одан 4 кәмпит артық. Екінші қорапта қанша кәмпит бар?

2) Бір қорапта 26, екінші қорапта болса одан 4 кәмпит артық. Екі қорапта қанша кәмпит бар?



8.  $80 + \bigcirc = 87$        $53 - \bigcirc = 50$   
 $\bigcirc - 5 = 30$        $\bigcirc + 24 = 48$   
 $90 + \bigcirc = 98$        $46 - \bigcirc = 40$



9. Формаларды салыстыр:

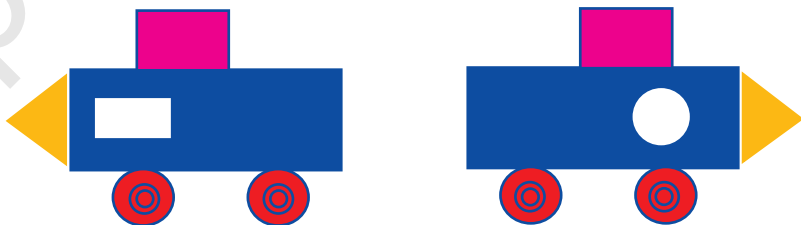

10.  $20 + 8 \square 30$        $35 - 5 \square 43$        $80 + 2 \square 82$   
 $69 - 9 \square 50$        $90 + 3 \square 81$        $47 - 7 \square 40$   
 $40 + 5 \square 45$        $96 - 6 \square 85$        $70 + 7 \square 55$





# Қызықты есептер шешу



1. Сызба негізінде есеп құрастыр және оны шеш:

1)

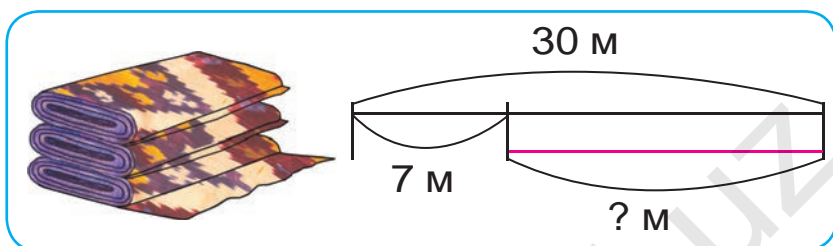

2)

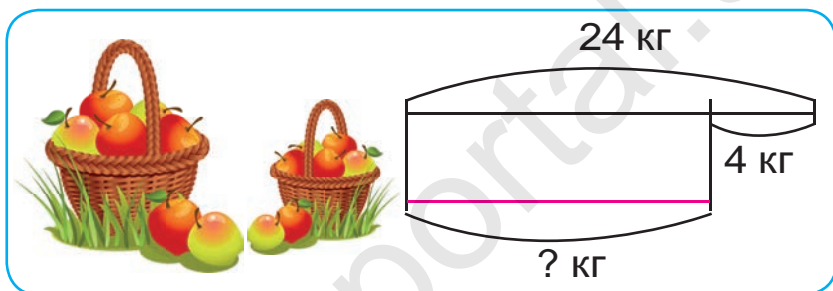

2. Сурет үйірмесіне 18 оқушы қатысатын еді, кейін және 10 оқушы қосылды. Бірақ 4 оқушы басқа үйірмеге өтіп кетті. Сурет үйірмесінде қанша оқушы қалды?



3.

Азайғыш	100	99	86	46	94	56
Азайтқыш	10	49	20	24	31	32
Айырма						



4. Өрнектің мәнін есепте:

$33 + 16$

$42 + 37$

$54 + 33$

$87 - 25$

$79 - 38$

$95 - 52$



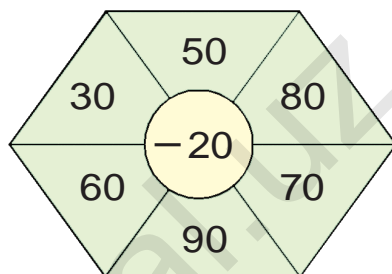
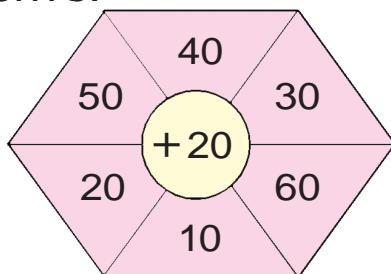

 5. Сырлаушы бір күнде 38 терезені сырлауы керек еді. Олар түске дейін 28 терезені сырлады. Сырлаушылар тағы неше терезені сырлау керек?

 6. Есепте:



 7. Сыныпта барлығы 32 оқушы бар. Сабаққа 10 қыз және 20 ұл бала келді. Сабаққа неше оқушы қатыспады?

 8. Кесте негізінде есеп құрастыр және оны шеш:

Бар еді	Келтірілді	Болды
 40 литр жанармай	 Және 40 литр жанармай	 ? литр жанармай

9. Мысалдардың шешімін түсіндір:

$$53 - 23 + 27 - 17 + 40 = ?$$

10.  $97 - 7$

$32 + 6$

$68 - 60$

$43 + 7$

$72 - 10$

$87 - 80$

## Өтілгендерді қайталау



1. Мектеп шеберханасы үшін 15 қолара және одан 3 сүргі сатып алынды. Мектеп шеберханасы үшін барлығы болып неше ағаш жасау құралы сатып алынған?

2. Мысалдардың жауабын өсу ретімен орналастыр:

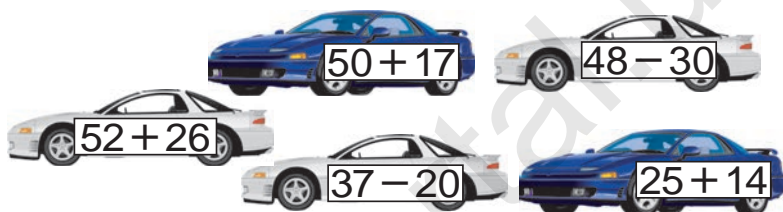

3.  $50 + \bigcirc = 57$        $94 - \bigcirc = 90$   
 $\bigcirc - 22 = 22$        $\bigcirc + 14 = 64$   
 $48 + \bigcirc = 60$        $30 - \bigcirc = 10$

4. Ойла, ізде, тап!

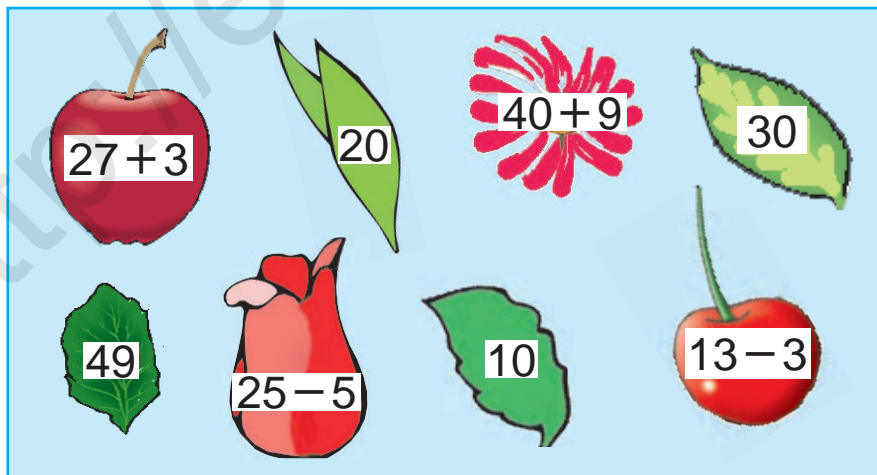

5.  $32 + 18$        $54 - 50$        $50 + 50$   
 $72 - 70$        $74 + 26$        $87 - 80$





6. Дүкенге сату үшін 76 екі және үш дөңгелекті велосипед алып келінді. Үш дөңгелекті велосипедтер 34 болса, екі дөңгелекті велосипедтер нешеу?



7. Тез есепте:

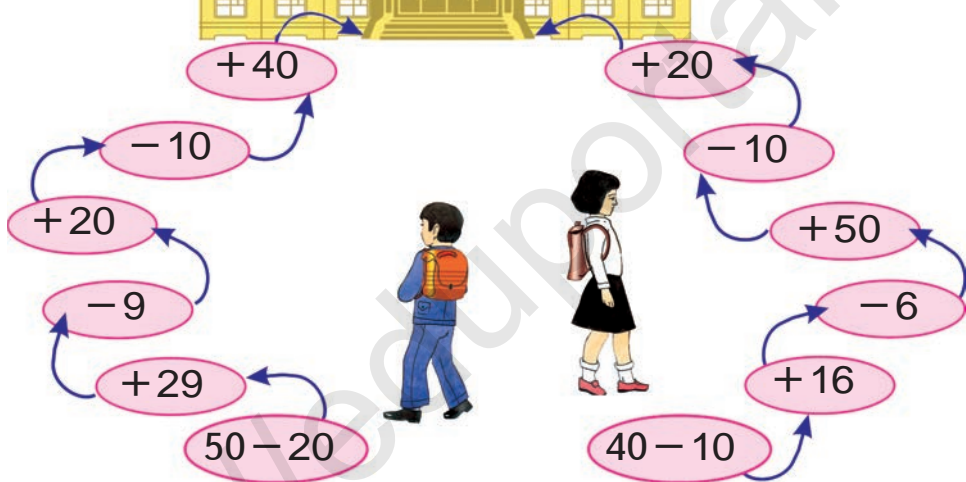

8. Неше үшбұрыш және төртбұрыш бар?

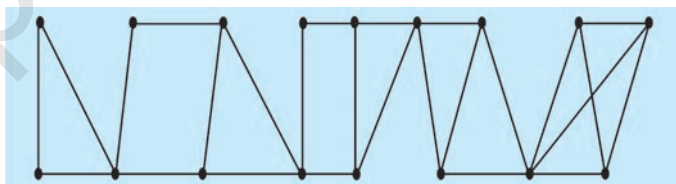

9.  $67 + 32$

$69 - 40$

$23 + 17$

$48 - 45$

$96 - 50$

$27 + 13$



10. 9 ондық және 7 бірліктен, 8 ондық және 5 бірліктен тұратын санды жаз:

## МАЗМҰНЫ

Заттар мен олардың қасиеттері. . . . .	3
1-ден 10-ға дейінгі сандарды ... . . . .	11
1-ден 5-ке дейінгі сандарды ... . . . .	15
6-дан 9-ға дейінгі сандарды ... . . . .	22
1-ден 10-ға дейінгі сандарды ... . . . .	31
Уақыт елестері. . . . .	32
Жұп және тақ сандар. . . . .	34
Нүкте. Түзу сызық кесіндісі. . . . .	35
Нөл қатысқан сандарды қосу және азайту. . . . .	37
Қосу амалының аталуы. . . . .	39
Азайту амалының аталуы . . . . .	40
Қосу және азайту амалдарының ... . . . .	41
11-ден 10-ге дейінгі сандардың ... . . . .	48
Жақшалар. . . . .	54
Сандарды ондық арқылы өтіп қосу . . . . .	56
Сандарды ондық арқылы өтіп азайту . . . . .	63
21-ден 100-ге дейінгі сандарды .... . . . .	73
Ондықтармен санау. . . . .	81
Ұзындық және оның бірлігі: сантиметр . . . . .	83
Бұрыш және оның түрлері . . . . .	90
Көпбұрыштар . . . . .	91
Есеп шешуді үйренеміз. . . . .	94
Қосу және азайту амалдарының ... . . . .	97
Масса өлшем бірлігі: килограмм . . . . .	102
Сығым өлшем бірлігі: литр . . . . .	104
Заттардың айнадағы бейнесі . . . . .	106
Жай жазықты және кеңістікті фигуралар . . . . .	114
Ұзындық бірліктері: дециметр, метр. . . . .	119
Санды өрнектер. . . . .	126
Құрамды есептер. . . . .	129
Бөліктерден бүтінді, бүтіннен ... . . . .	132
100 санынан бір таңбалы санды айыру . . . . .	139
100 санынан екі таңбалы санды айыру. . . . .	140

Екинші қосындыны табу . . . . .	141
Тізбектілікті жалғастыру . . . . .	144
Логикалық анықтамалар: «барлығы» ... . . . .	147
Берілген ұзындықтағы кесіндіні жасау ...	150
Түрлі фигуралар жасау . . . . .	153
Қызықты есептер шешу . . . . .	155
Өтілгендерді қайталау . . . . .	157

**Ахмедов М.** және басқалар

А 94 **Математика.** Жалпы орта білім беретін мектептердің 1-сыныбына арналған оқулық. ( **М. Ахмедов**, Н. Абдурахманова, М. Жумаев). — Т.: «Turon-Iqbol», 2019. — 160 бет.

**ISBN 978-9943-14-061-5**

**УДК: 372.851(075)**

**51=512.122**

**ББК 22.1я721**

**MAHAMADJON AHMEDOV**,

**NABIYA ABDURAHMONOVA, MAMANAZAR JUMAYEV**

O'quv nashri

## **МАТЕМАТИКА**

Umumiy o'rta ta'lim maktablarining  
1-sinfi uchun darslik

O'n uchinchi nashr

(qozoq tilida)

«TURON-IQBOL»

Toshkent, 100011. Navoiy ko'chasi, 30-uy.

Toshkent – 2019

Аударған	Г. Әмірқызы
Редакторы	Ө. Байқабылов
Көркемдеуші редактор	Е. Абдикайырова
Техникалық редакторы	А. Юлдашева
Корректоры	Ө. Байқабылов
Компьютерде беттеген	А. Мухаммадиев

Баспа лицензиясы АІ №223, 16.11.12.

Басуға 2019 жылы 17 май рұқсат етілді. Пішімі 70x100<sup>1/16</sup>.

Офсеттік әдіспен басылды. «Pragmatica» гарнитурасы. Шартты баспа табағы 12,9. Есептік б. т. 13,52. Таралымы 5 792 нұсқа. Тапсырыс 19-252.

Өзбекстан Республикасы Президенті Администрациясы құзырындағы Ақпарат және бұқаралық коммуникациялар агенттігінің «O'zbekiston» баспа-полиграфиялық шығармашылық үйінде басылды.

100011, Ташкент, Науаи көшесі, 30.