

DEUTSCH MACHT SPAß

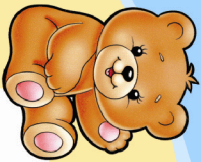

Toshkent-2013



DEUTSCH MACHT SPAß



Manzura Daddakhodjaeva,

Allia Bekanatschewa,

Renata Fayzulina,

Tanja Gafurova,

Luftulla Holijarow,

Orzigul Mirsoifowa,

Zuchra Norbekova,

Natalya Suchanowa,

Dilbar Tadshibaewa

Layout: Shuchrat Mirfayozov

Eine Fremdsprache schon in der ersten Klasse lernen? Ja, warum denn nicht?

Die Leistungsfähigkeit des kindlichen Gehirns wird durch Training erhöht. Je häufiger und intensiver das Kind eine Fremdsprache hört, desto besser wird sie erworben. Soziale und sprachliche Kommunikation fördern die Entwicklung des Gehirns. Kinder, die intuitiv und nicht nach Regeln lernen, erwerben eine Fremdsprache müheloser und schneller als Erwachsene. Deshalb stehen Spielerisches Lernen und Handlungsorientierung im Vordergrund unseres Lehrbuches.

Das Material gliedert sich die Teile:

Die Teile des Lehrwerks

Band 1 des Lehrwerks „Deutsch macht Spaß“ ist für den Einsatz in der 1. Klasse der allgemeinbildenden Schulen in Usbekistan gedacht.

Es besteht aus:

- einem integrierten Lehr- und Arbeitsbuch
- einem Lehrerhandbuch;
- einer multimedialen Begleitung;

Das Lehrbuch ist in vierzehn Lektionen eingeteilt. Jede der vierzehn Lektionen gliedert sich in 2 Seiten, auf der linken Seite, ist das Lehrbuch (LB), auf der rechten Seite das Arbeitsbuch (AB) angeordnet.





BEKANNTSCHAFT

Begrüßung

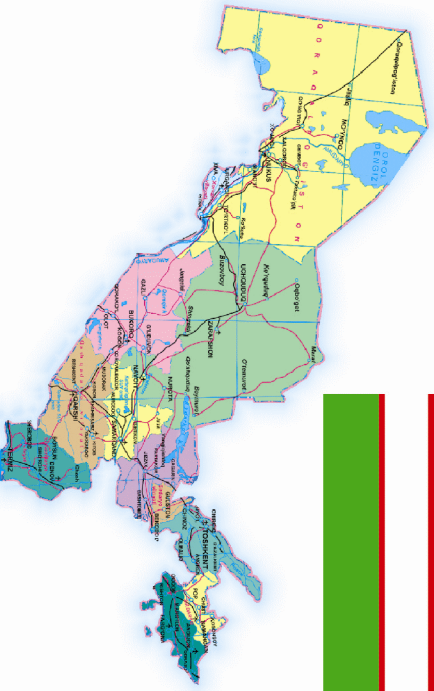
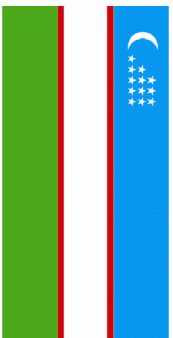

BEKANNTSCHAFT

Begrüßung

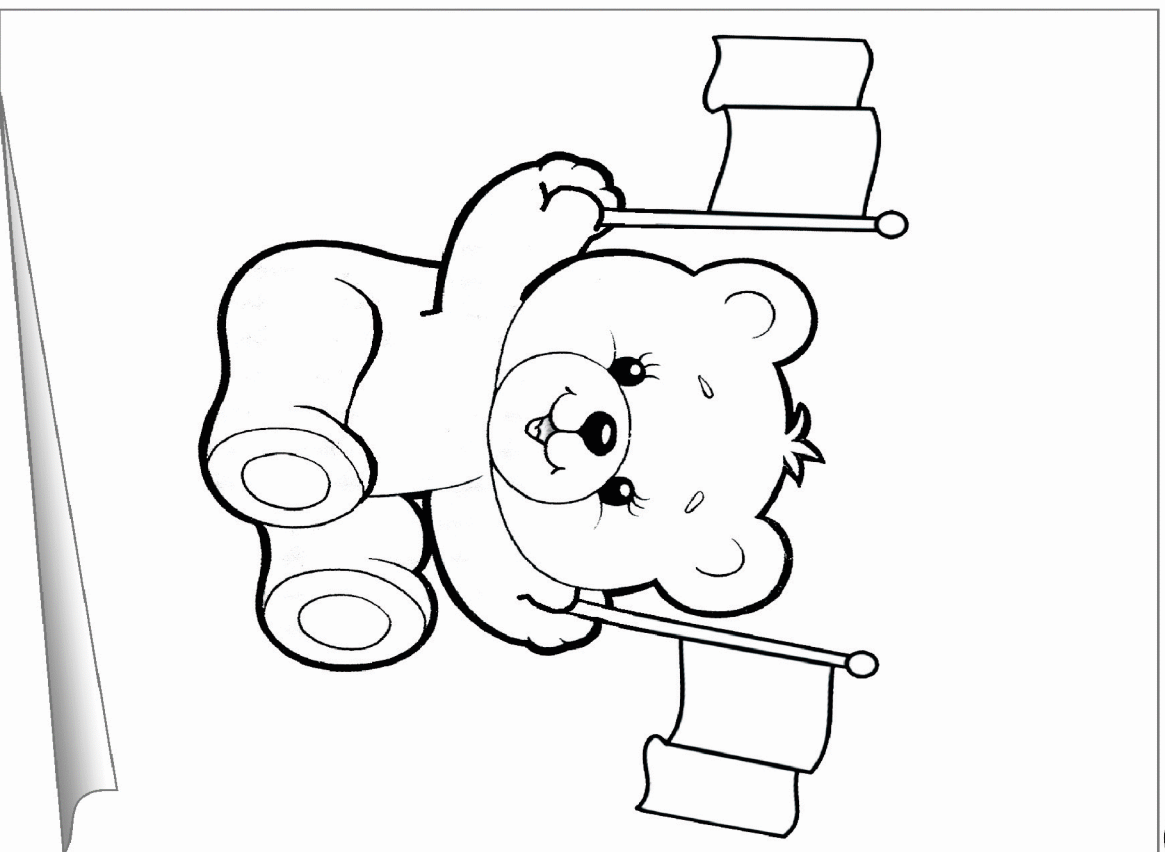

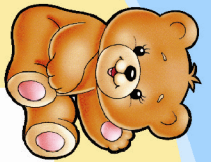

BEKANNTSCHAFT

Sich verabschieden

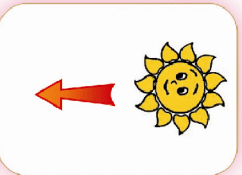
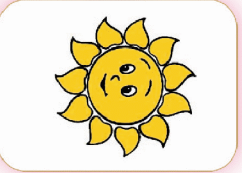
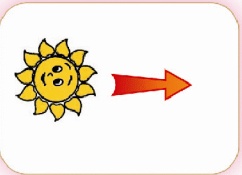
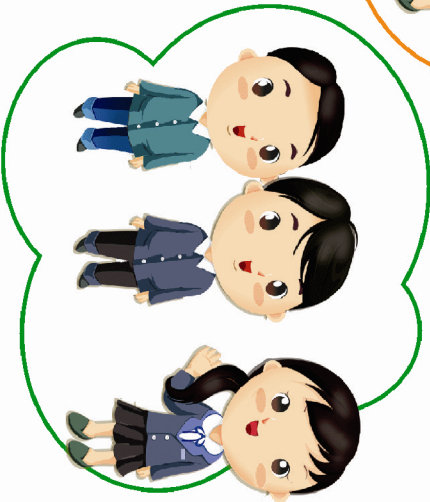

BEKANNTSCHAFT

Sich verabschieden

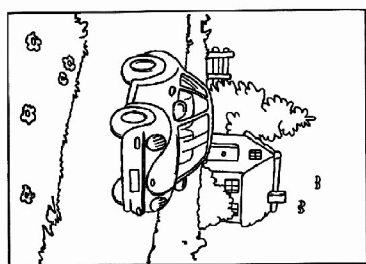
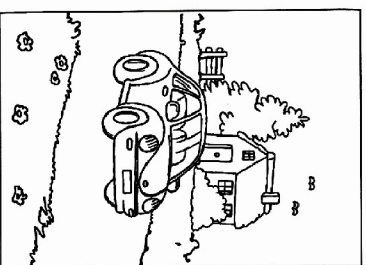
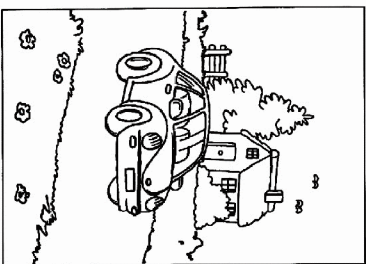
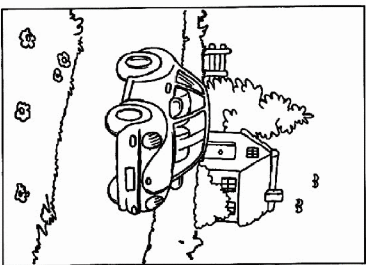
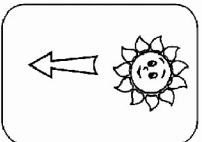
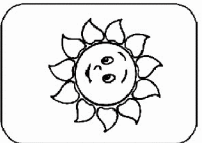
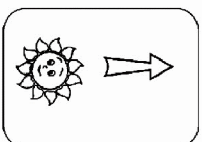

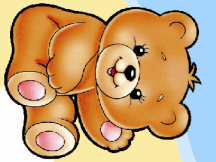

1

BEKANNTSCHAFT

Wie geht es?

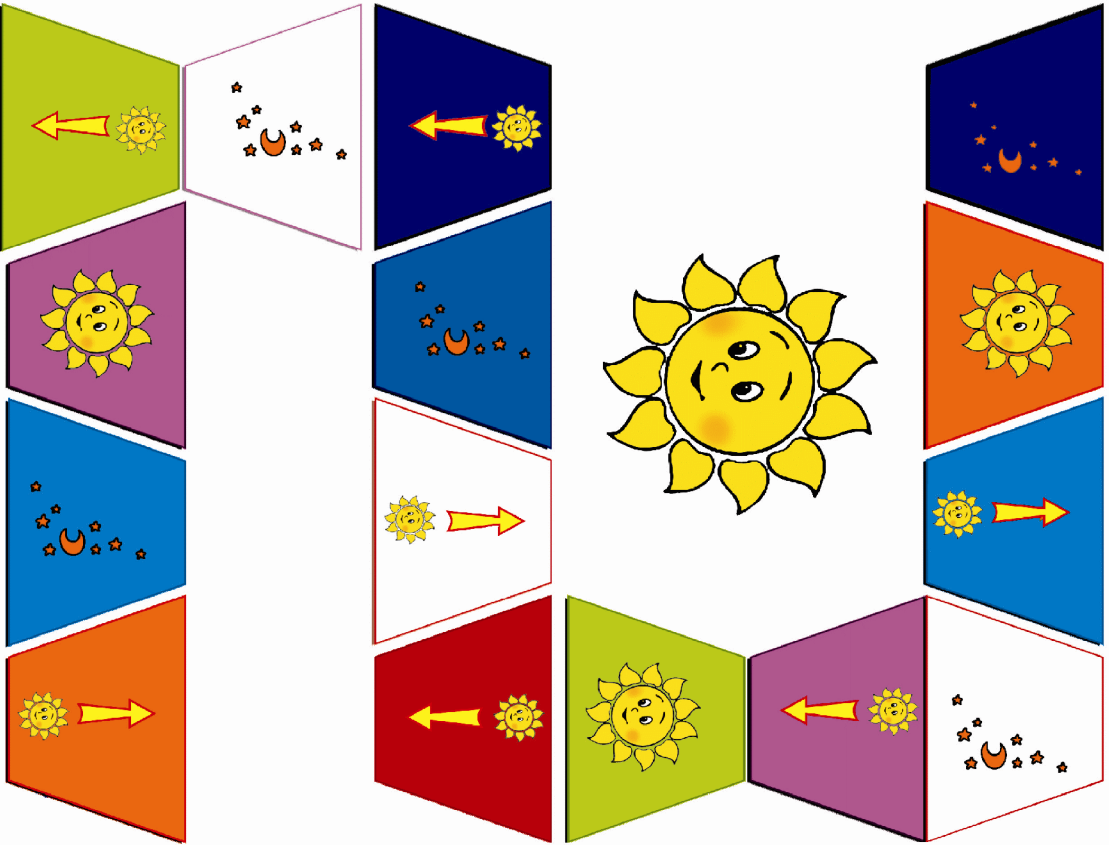

1

BEKANNTSCHAFT

Wie geht es?

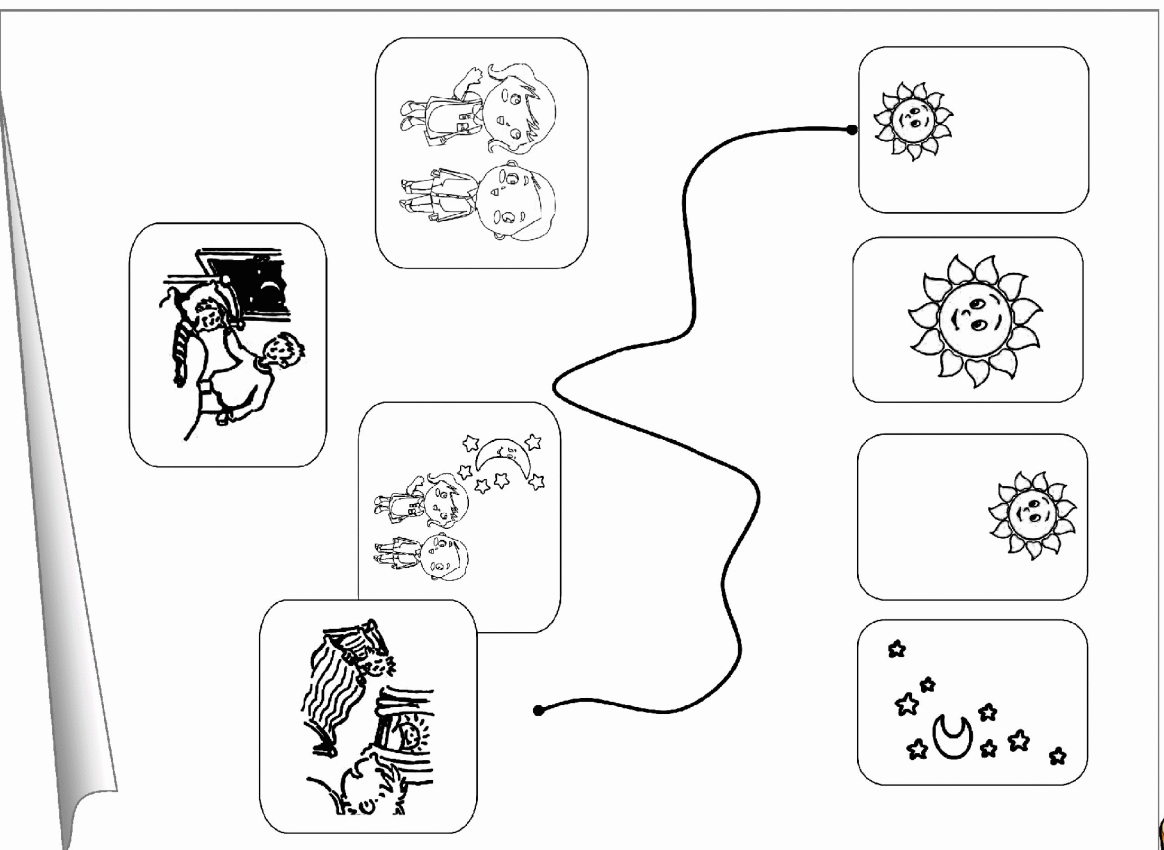



BEKANNTSCHAFT



BEKANNTSCHAFT

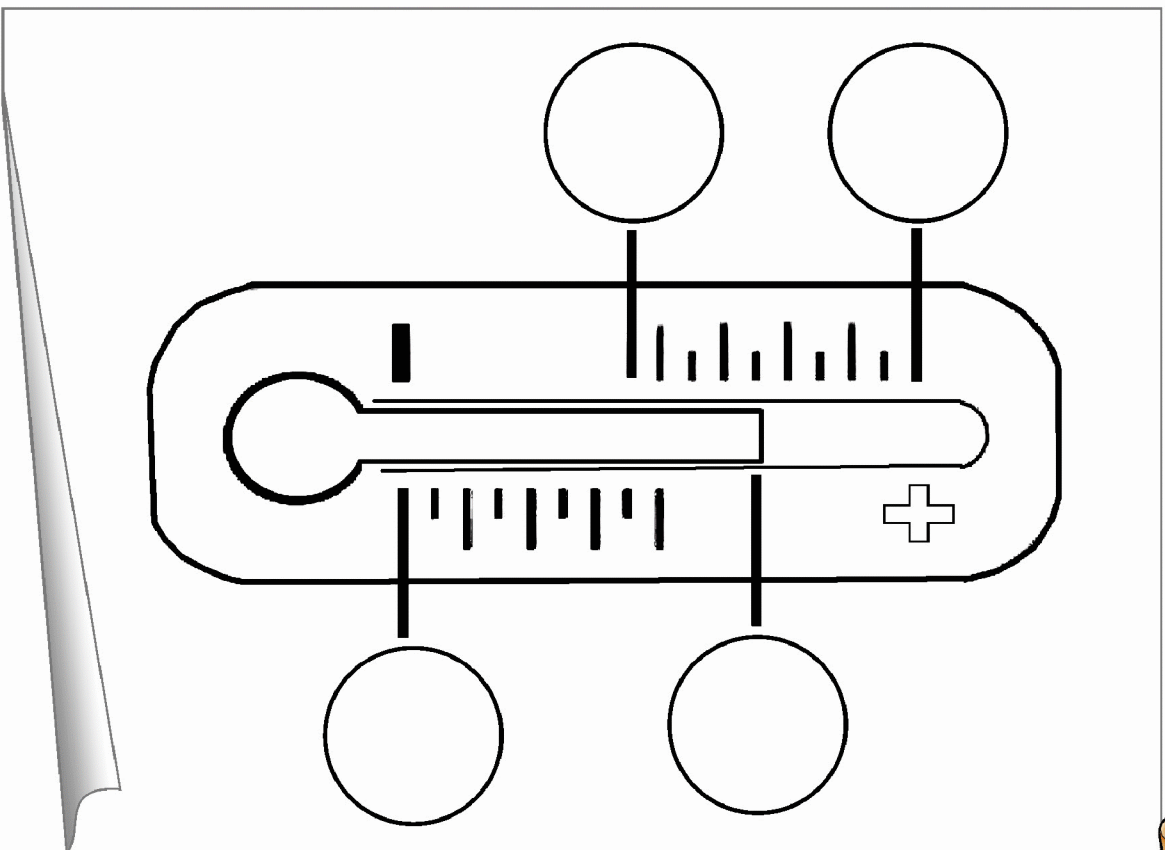
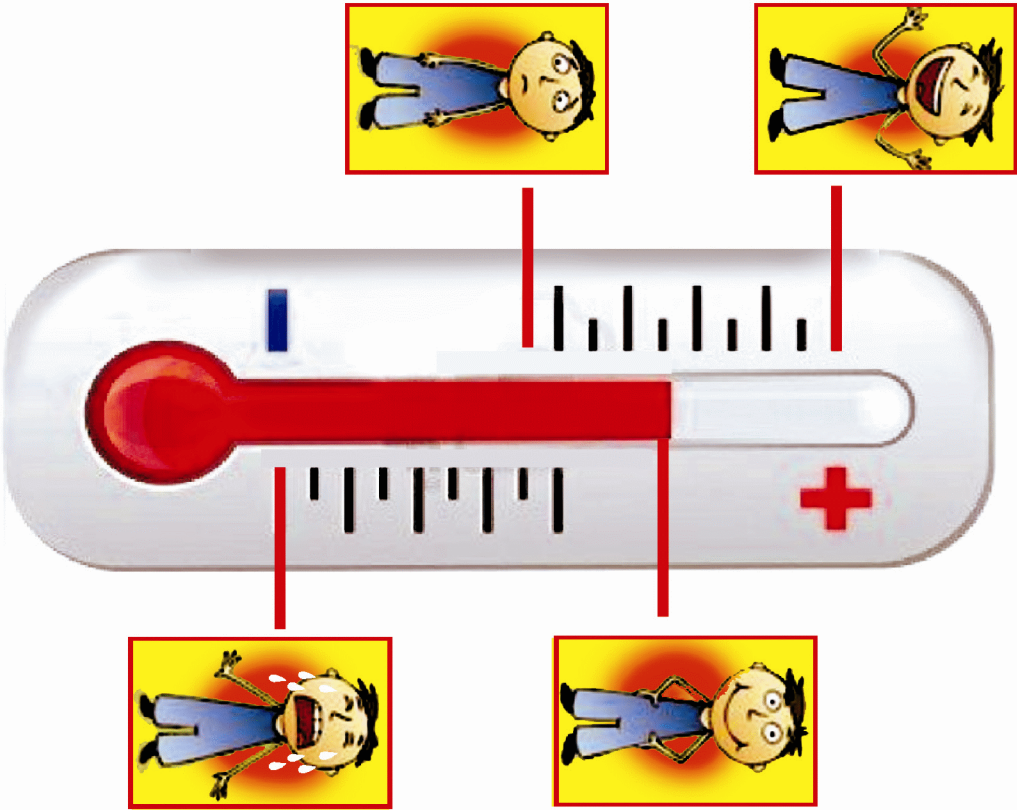

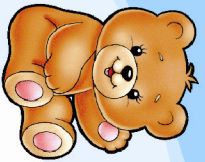

ALLES ÜBER MICH

Sich vorstellen



ALLES ÜBER MICH

Sich vorstellen

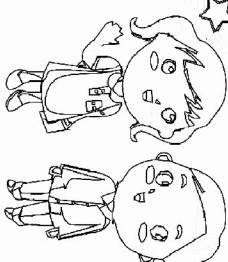
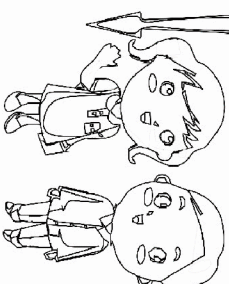
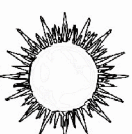
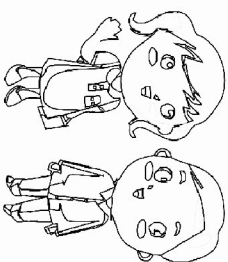

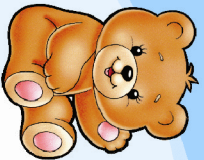

ALLES ÜBER MICH

Ich, du, er, sie, es

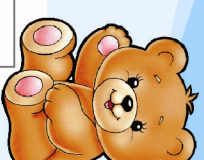
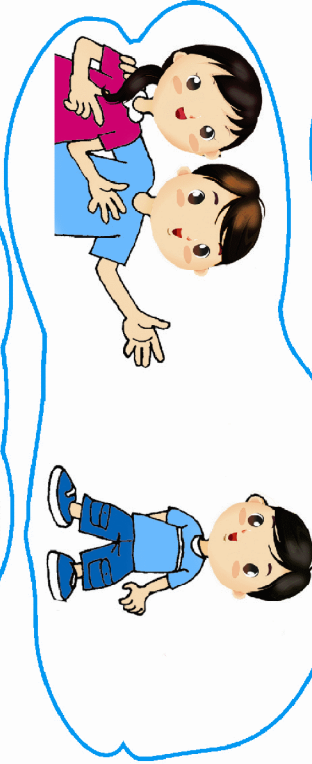
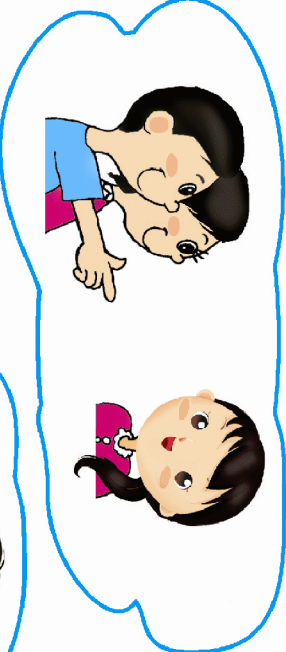
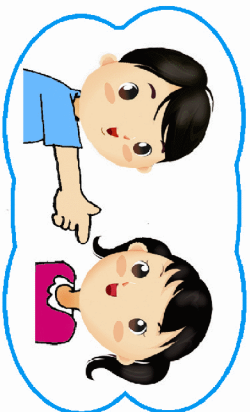
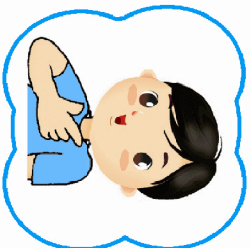

ALLES ÜBER MICH

Ich, du, er, sie, es

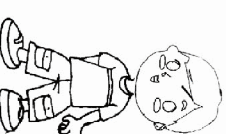



ALLES ÜBER MICH

Wie alt bist du?

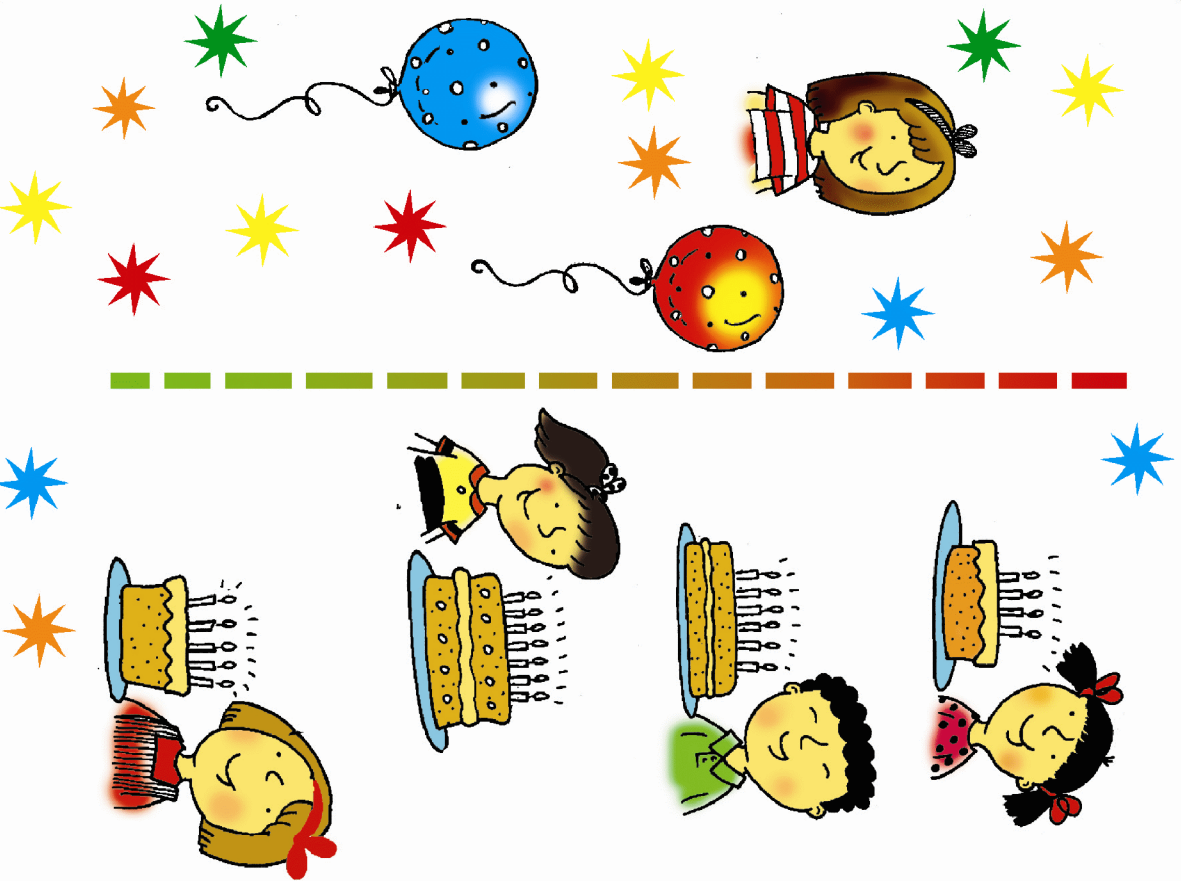

ALLES ÜBER MICH

Wie alt bist du?

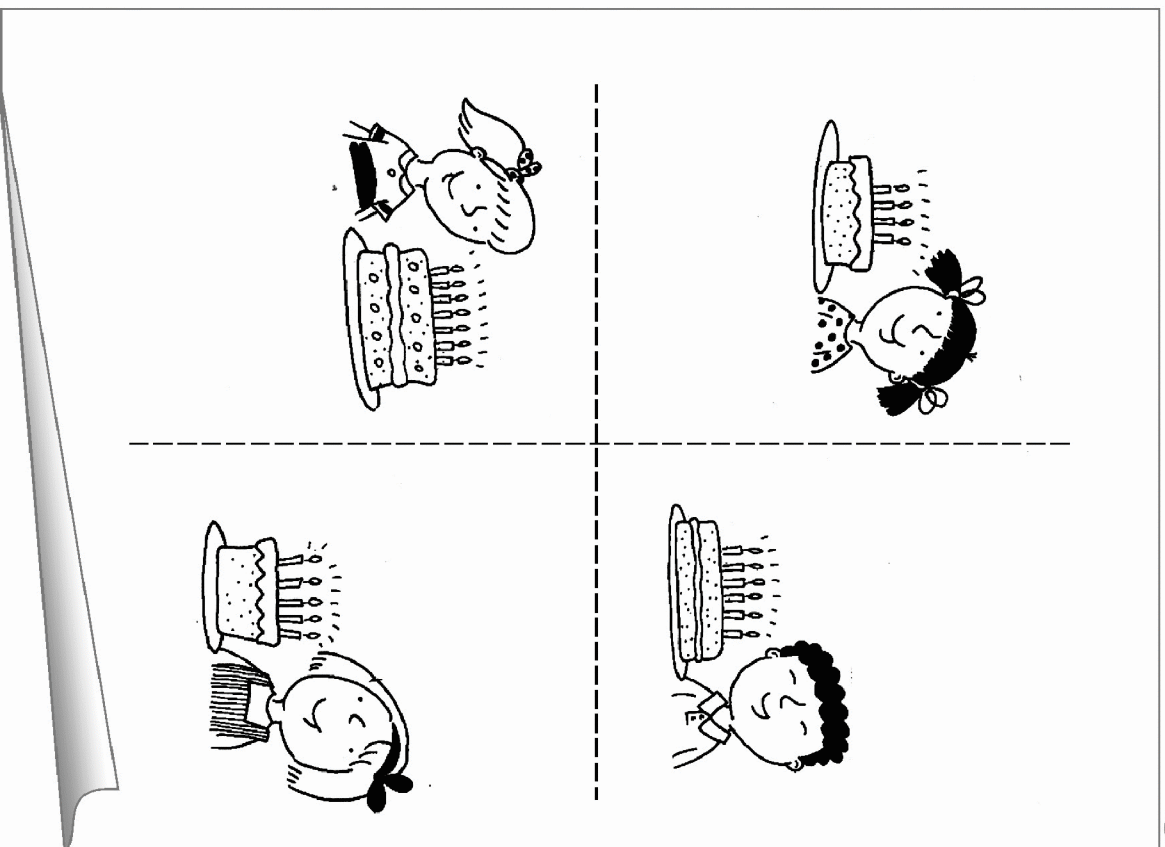



ALLES ÜBER MICH

Wo wohnst du?



ALLES ÜBER MICH

Wo wohnst du?

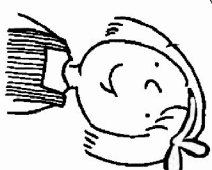
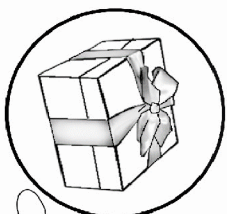
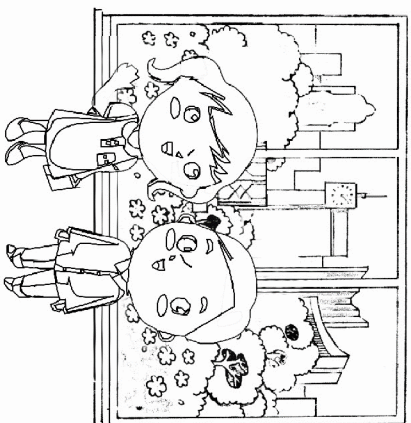
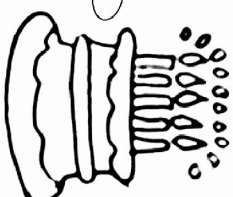
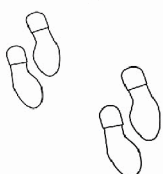
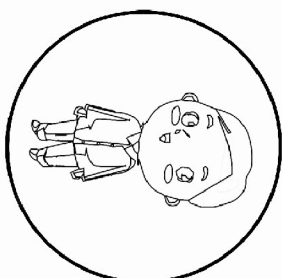



FAMILIE
Familie stellt sich vor



FAMILIE
Familie stellt sich vor





FAMILIE

Wie heißt du?

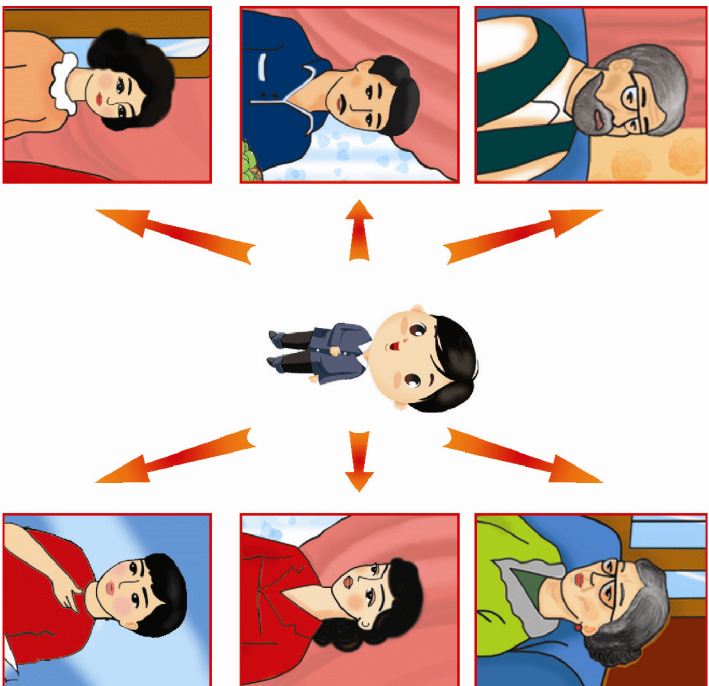

FAMILIE

Wie heißt du?

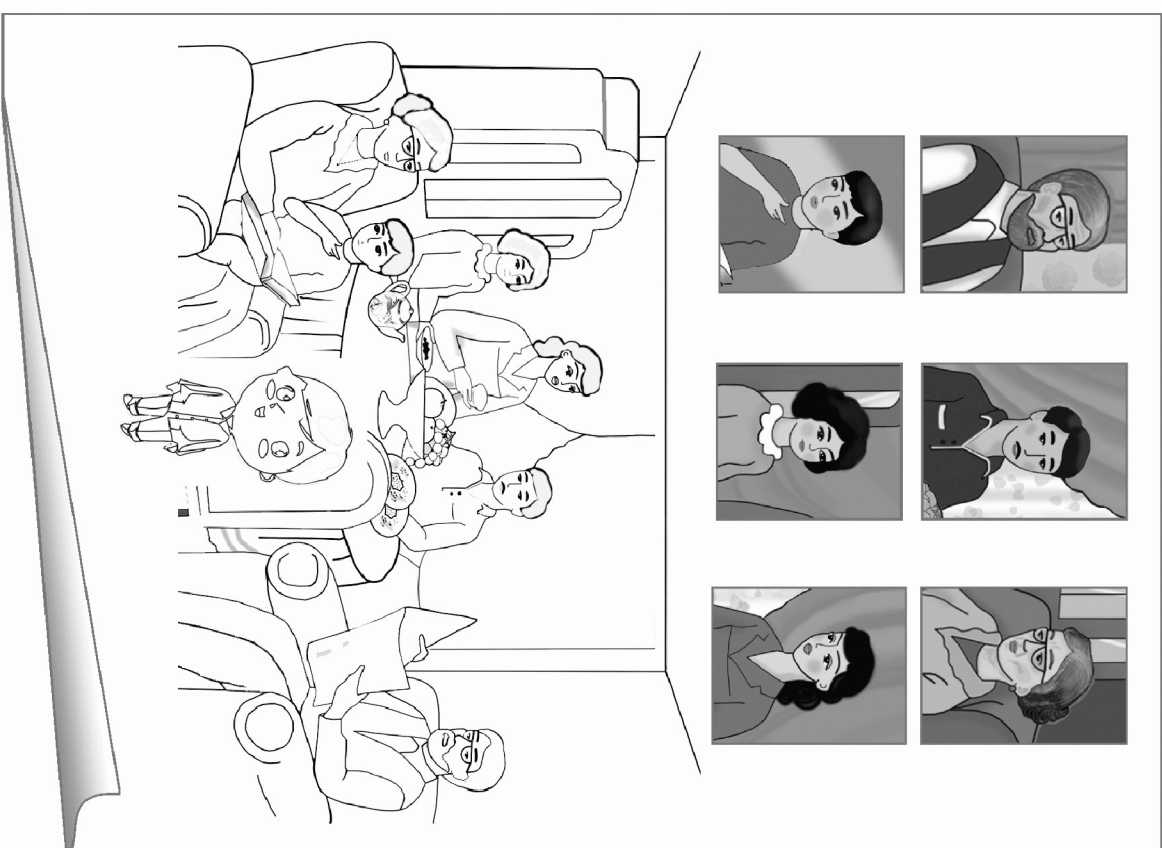



FAMILIE
Partnerarbeit

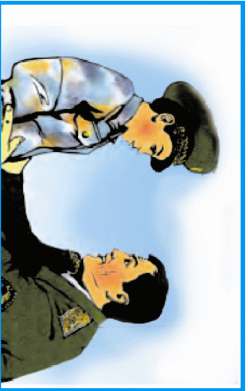
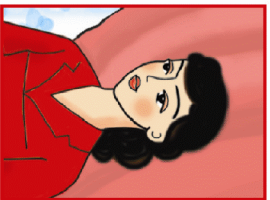

FAMILIE
Partnerarbeit

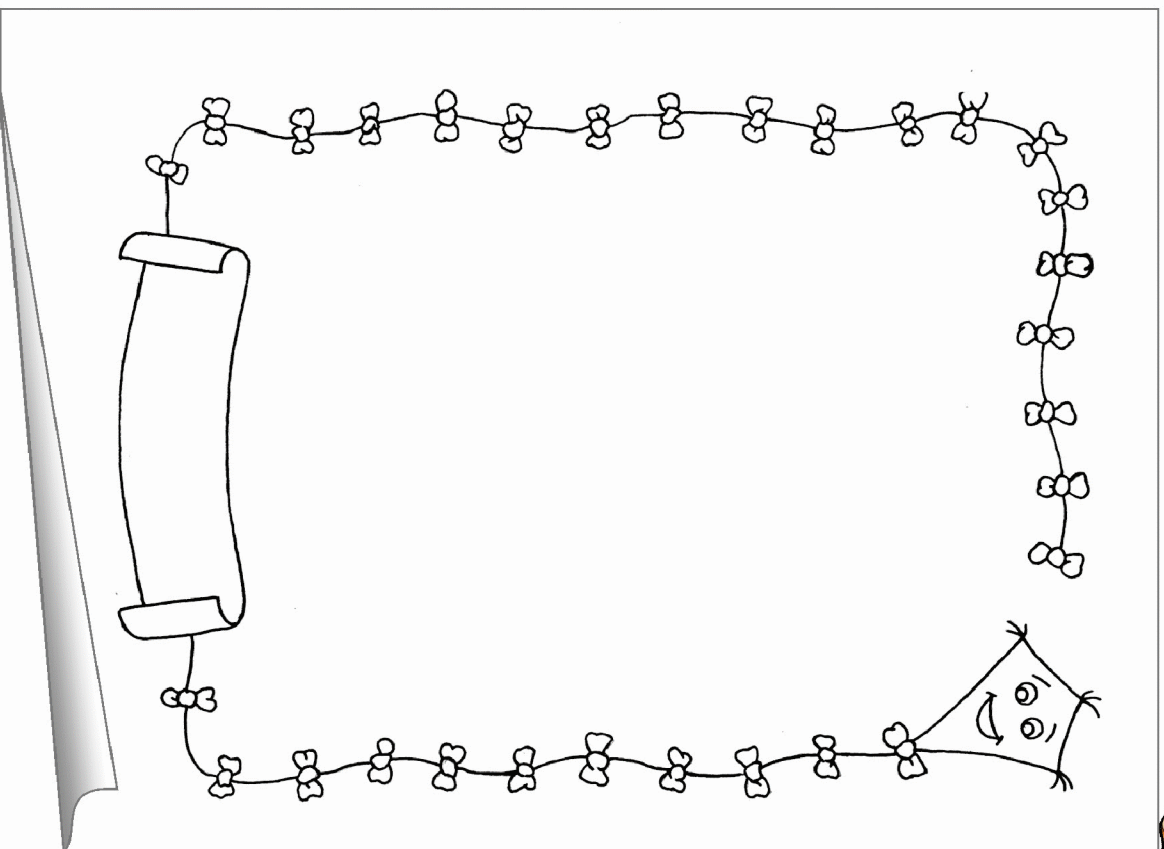

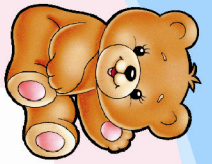

FAMILIE
Meine Familie.....



FAMILIE
Meine Familie.....

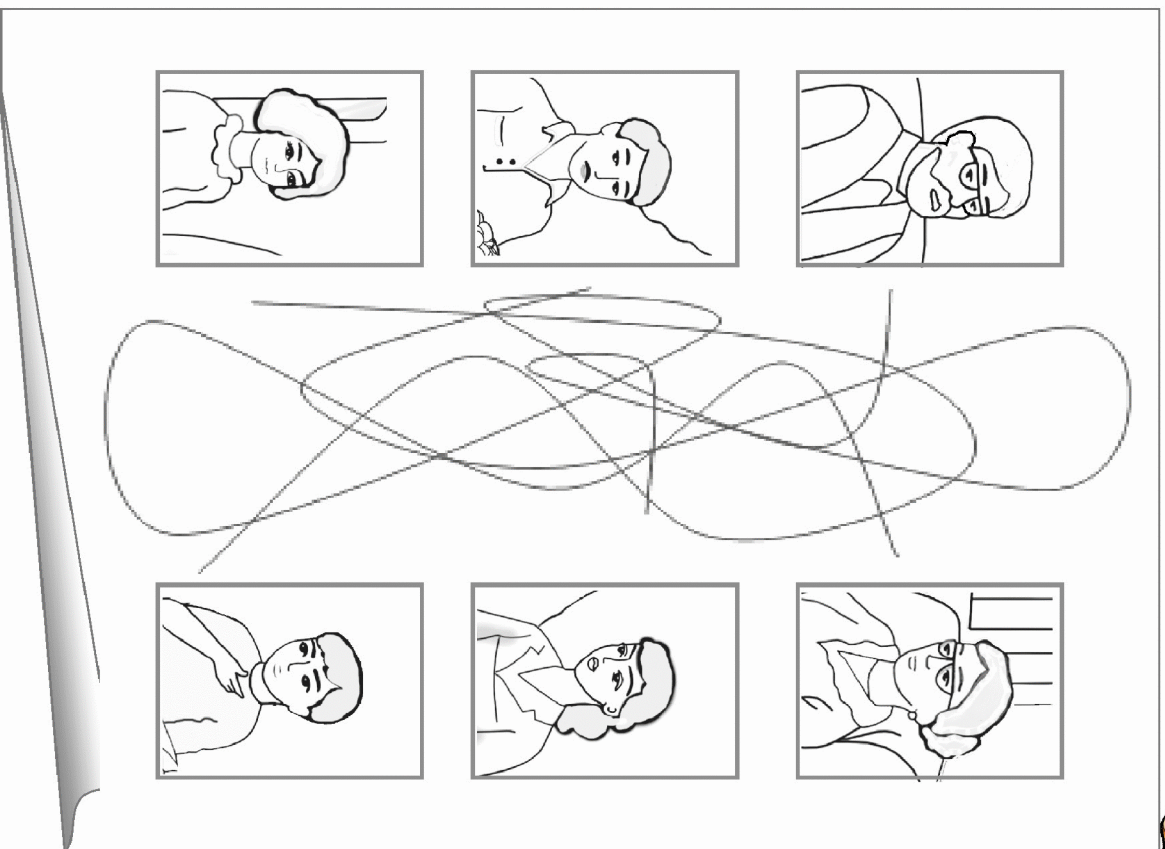
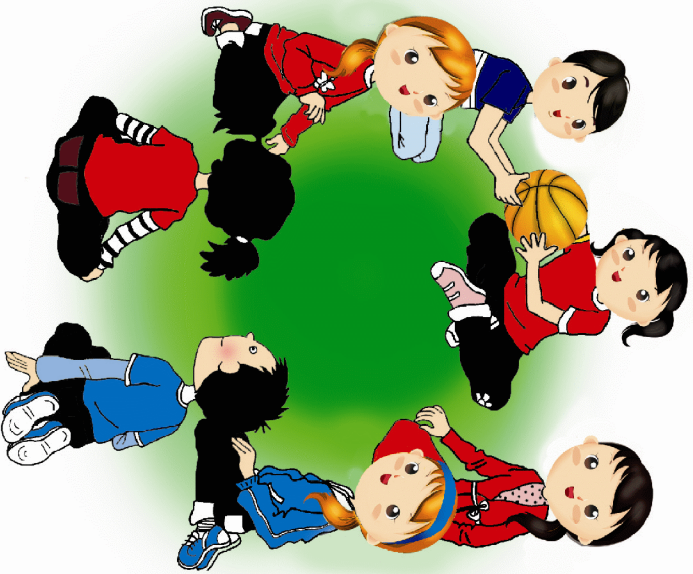
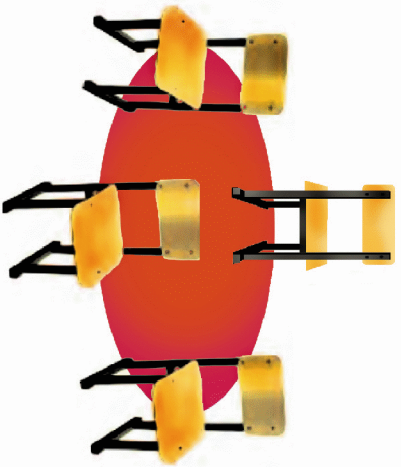

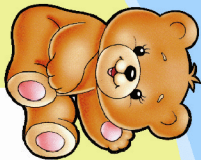

MEIN FREUND

Mein Freund heißt....



MEIN FREUND

Mein Freund heißt....

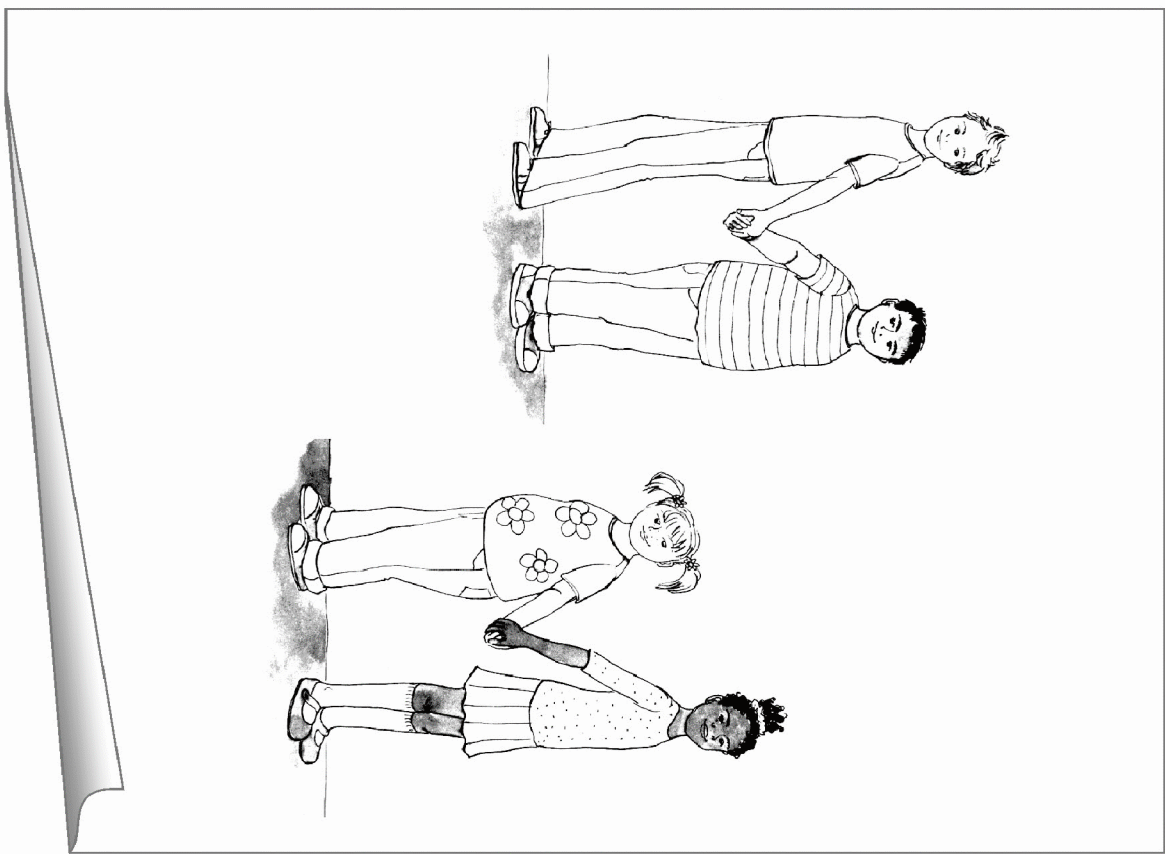

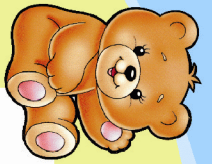

MEIN FREUND

Mein Freund ist.....

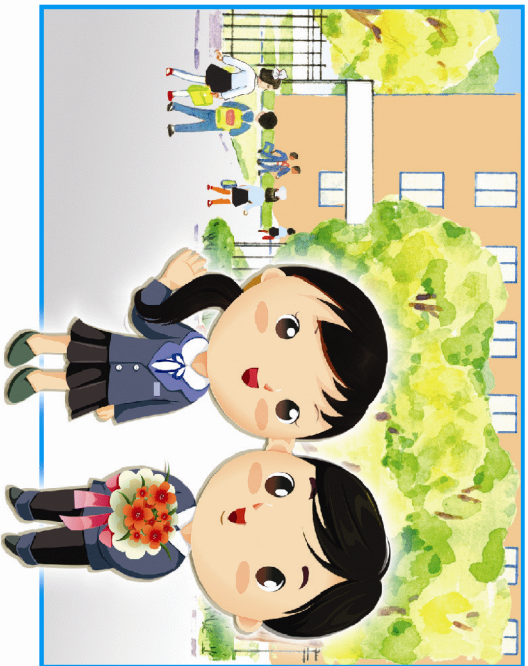
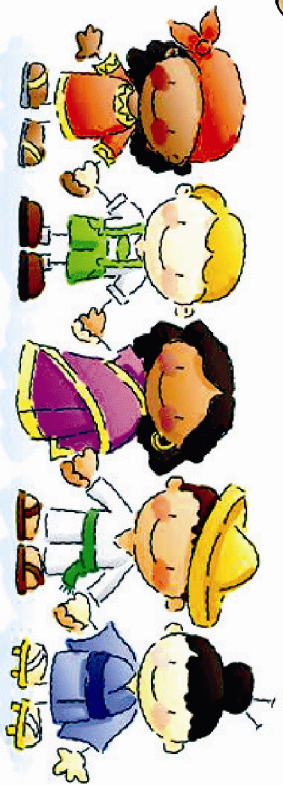

MEIN FREUND

Mein Freund ist.....

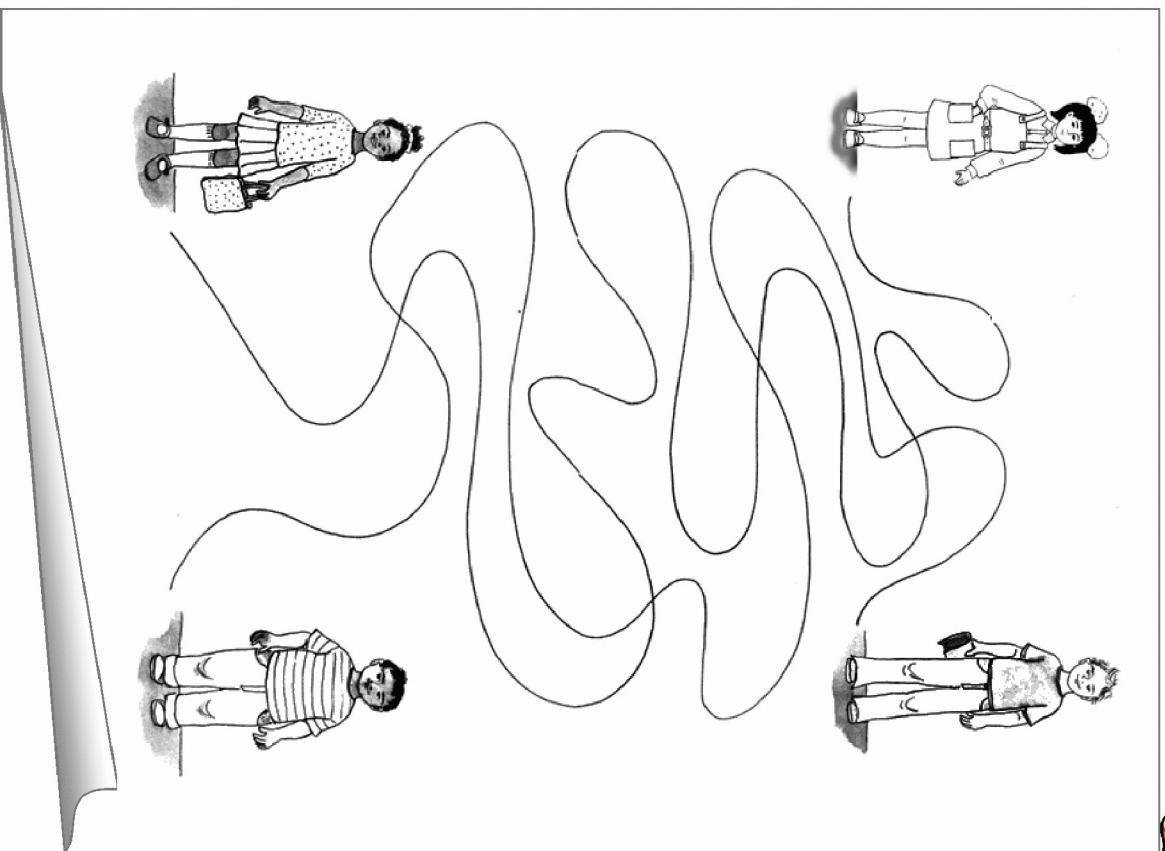



MEIN FREUND

Wohnort

MEIN FREUND

Wohnort

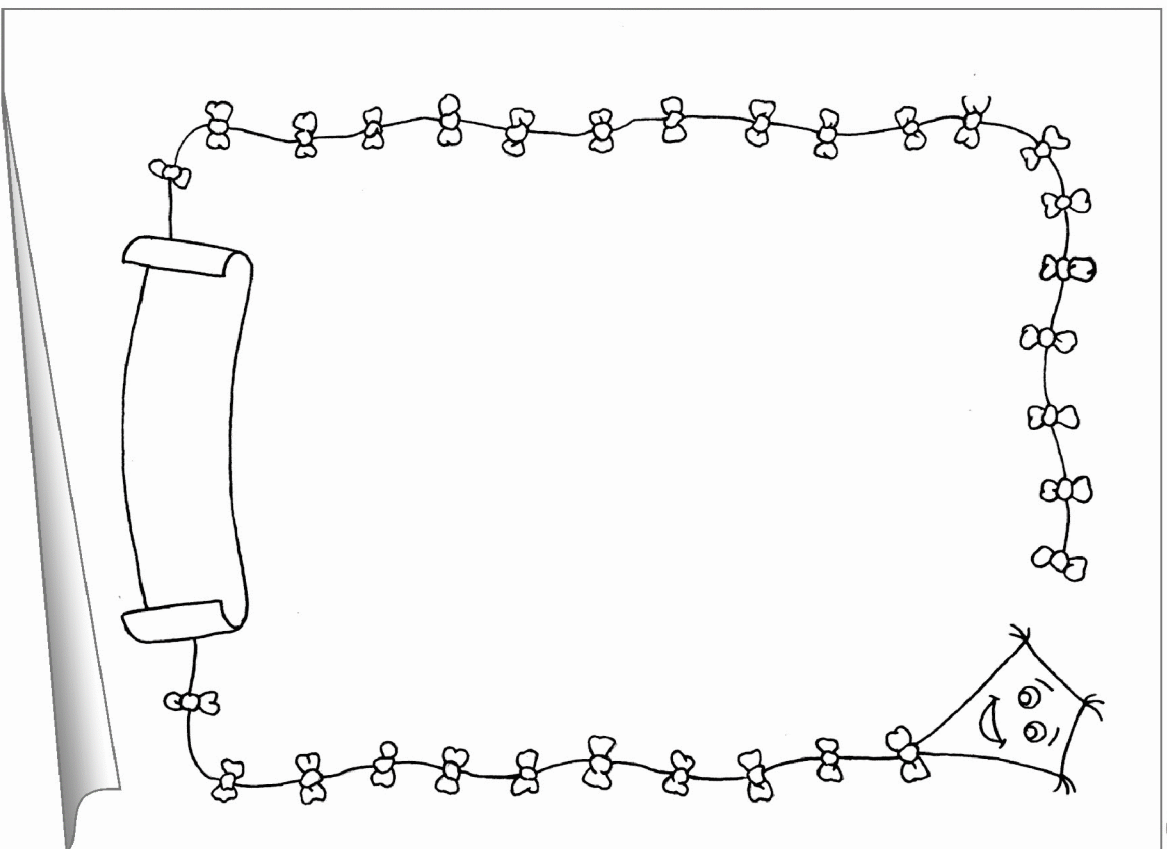
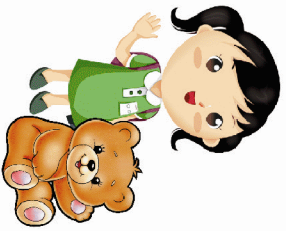

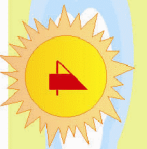

MEIN FREUND

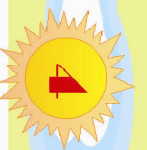
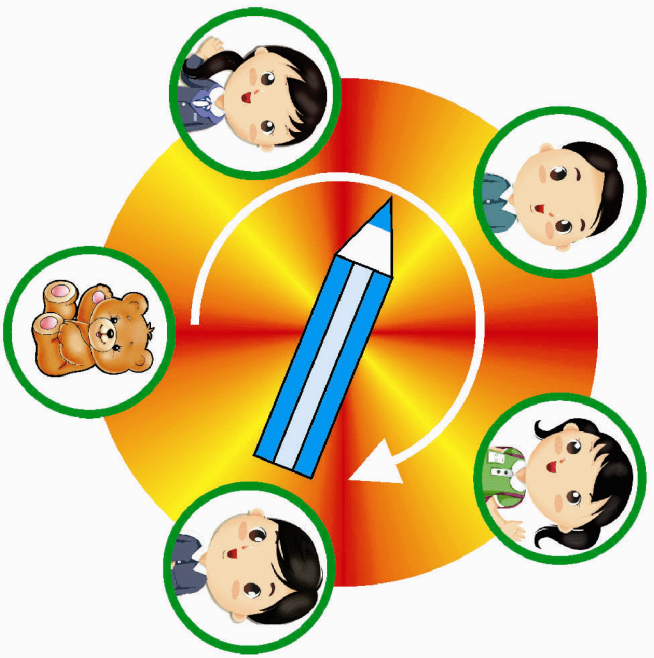

MEIN FREUND

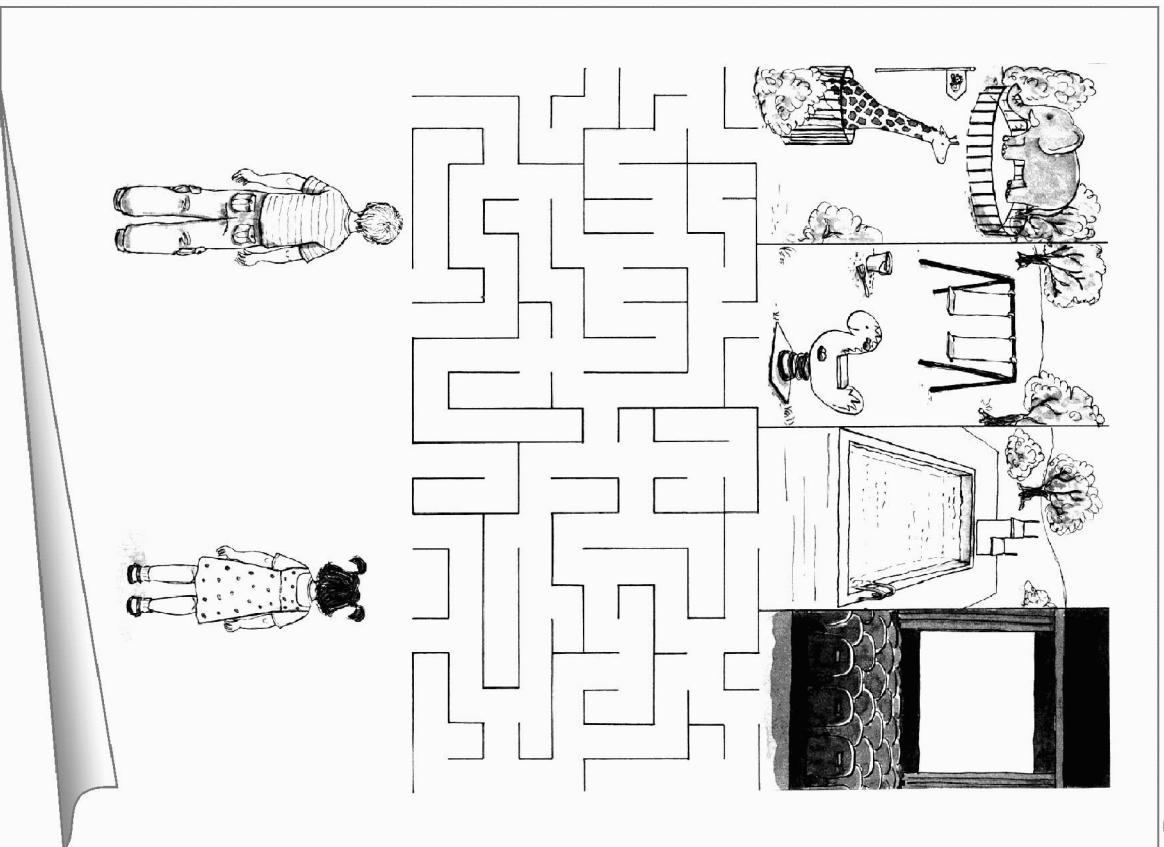

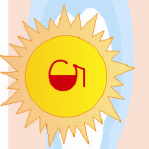

FARBEN

Ist das Rot?



FARBEN

Ist das Rot?

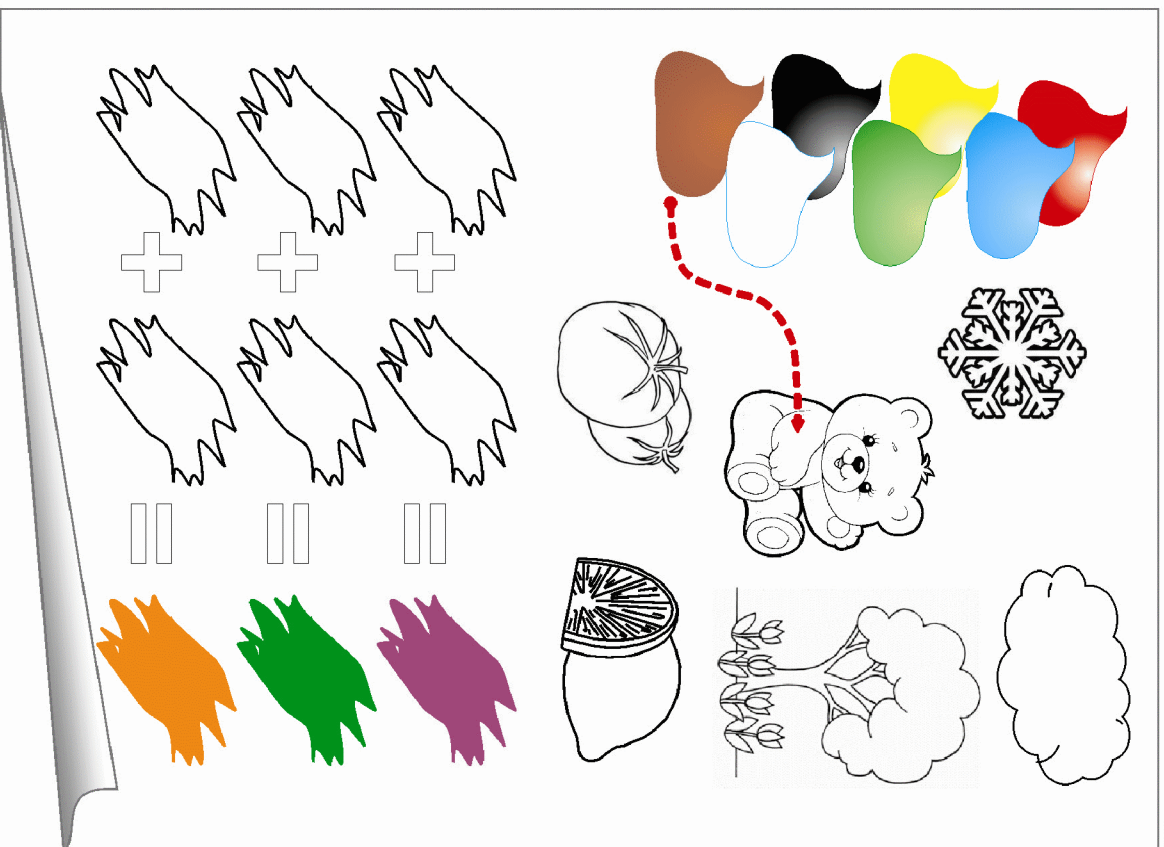



FARBEN

Gegenstände und Farben

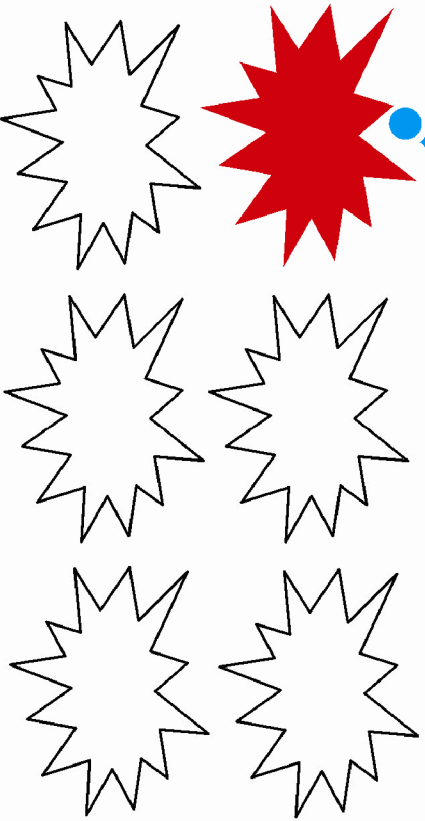

FARBEN

Gegenstände und Farben

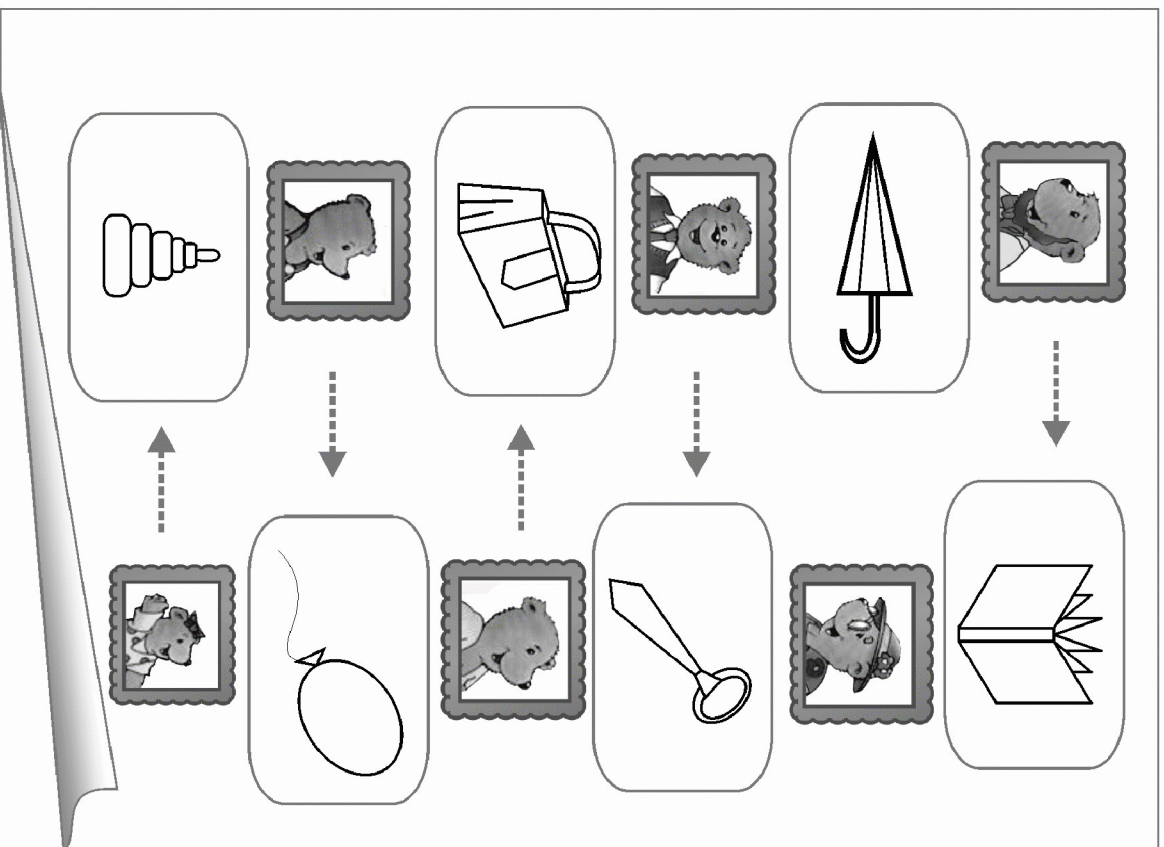

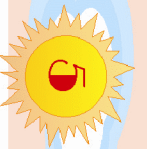
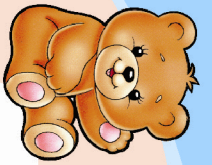

FARBEN

Gegenstände und Farben



FARBEN

Gegenstände und Farben

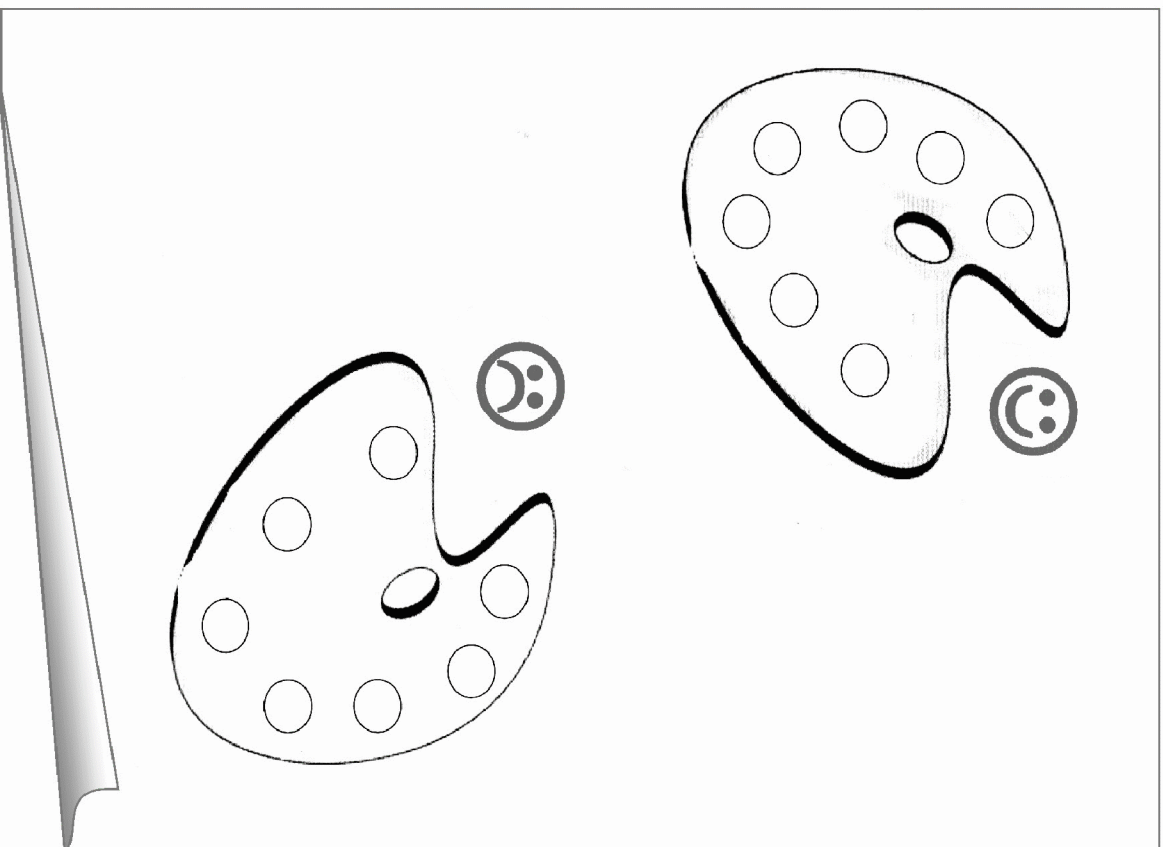

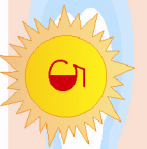
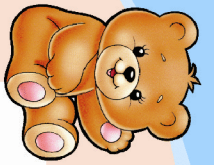

FARBEN

Farben und Formen

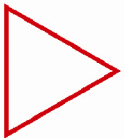
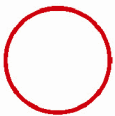
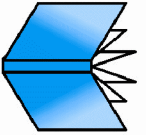
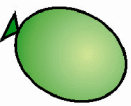
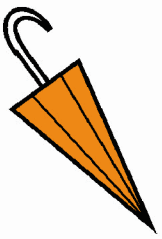
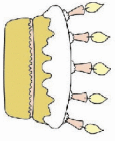
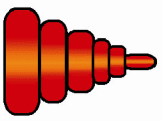



FARBEN

Farben und Formen

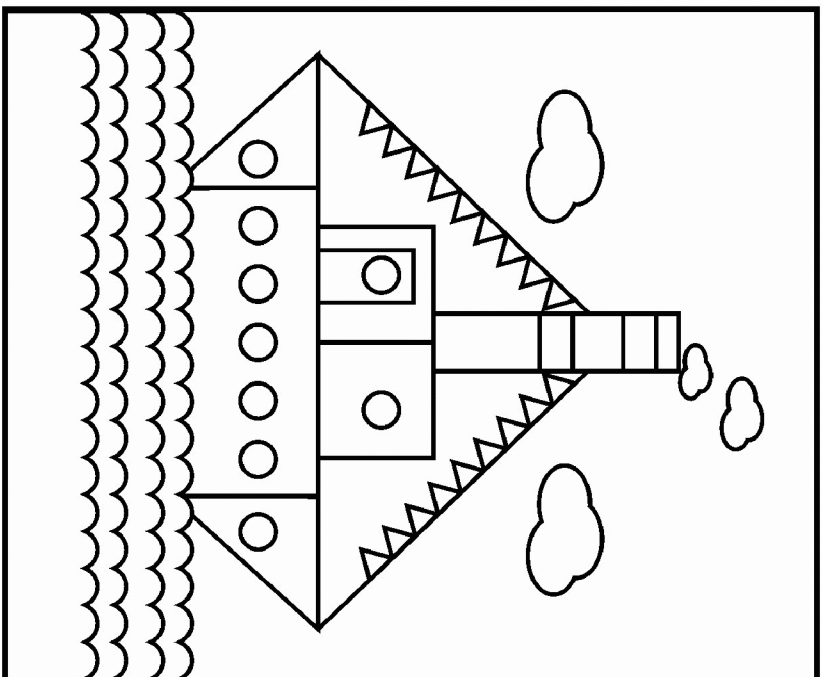
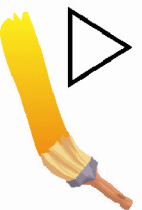



SPIELZEUGE

Mein Freund heißt....

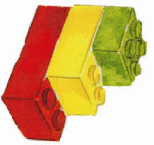
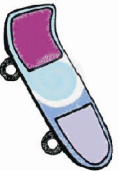

SPIELZEUGE

Mein Freund heißt....

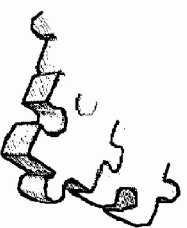
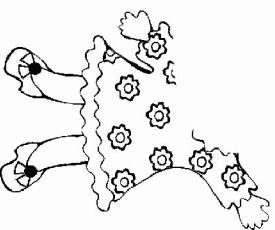
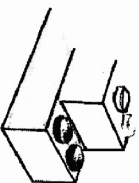
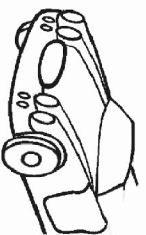



SPIELZEUGE

As fehlt?

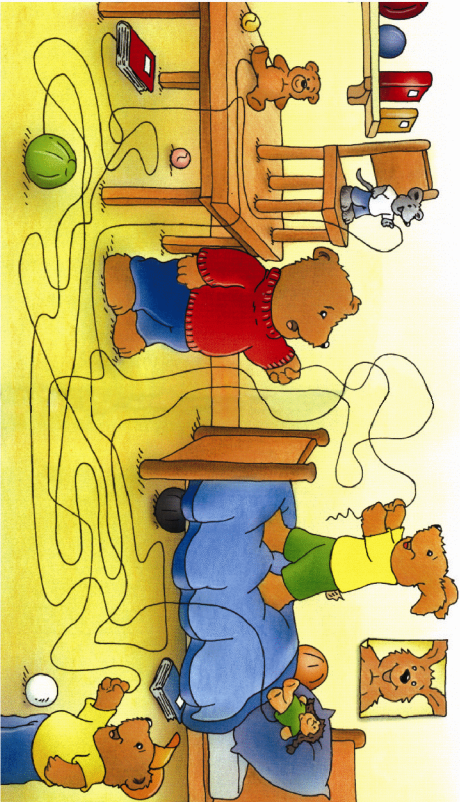
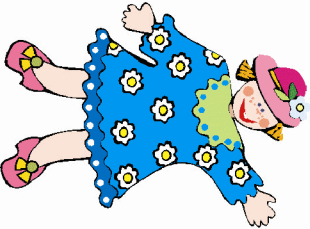
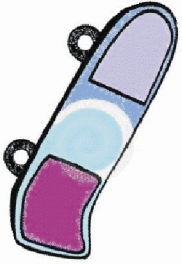
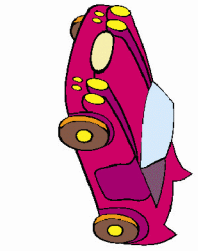
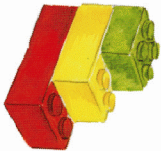
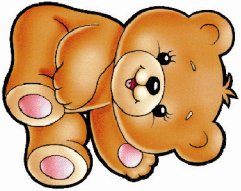

SPIELZEUGE

As fehlt?

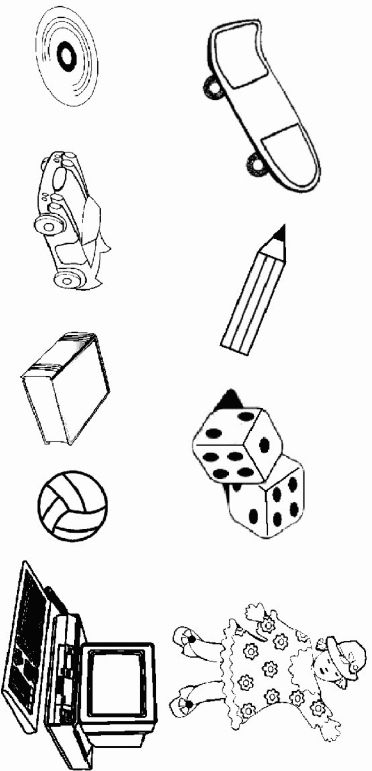



SPIELZEUGE

Ich spiele gern....

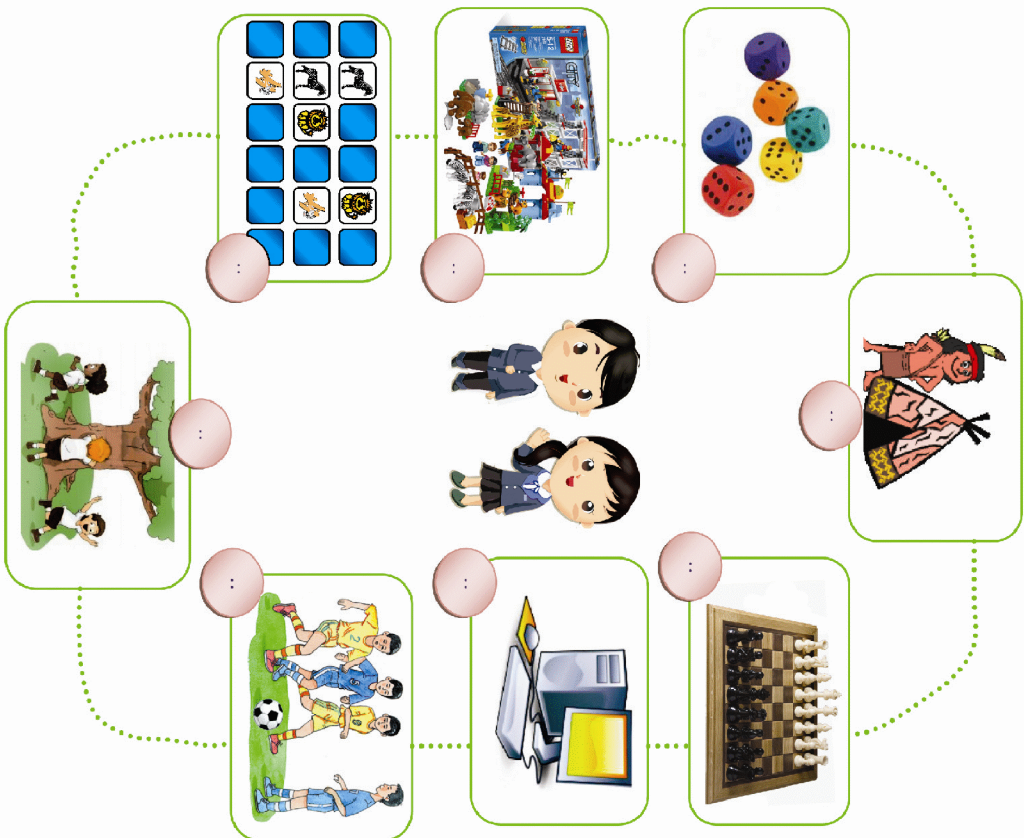

SPIELZEUGE

Ich spiele gern....

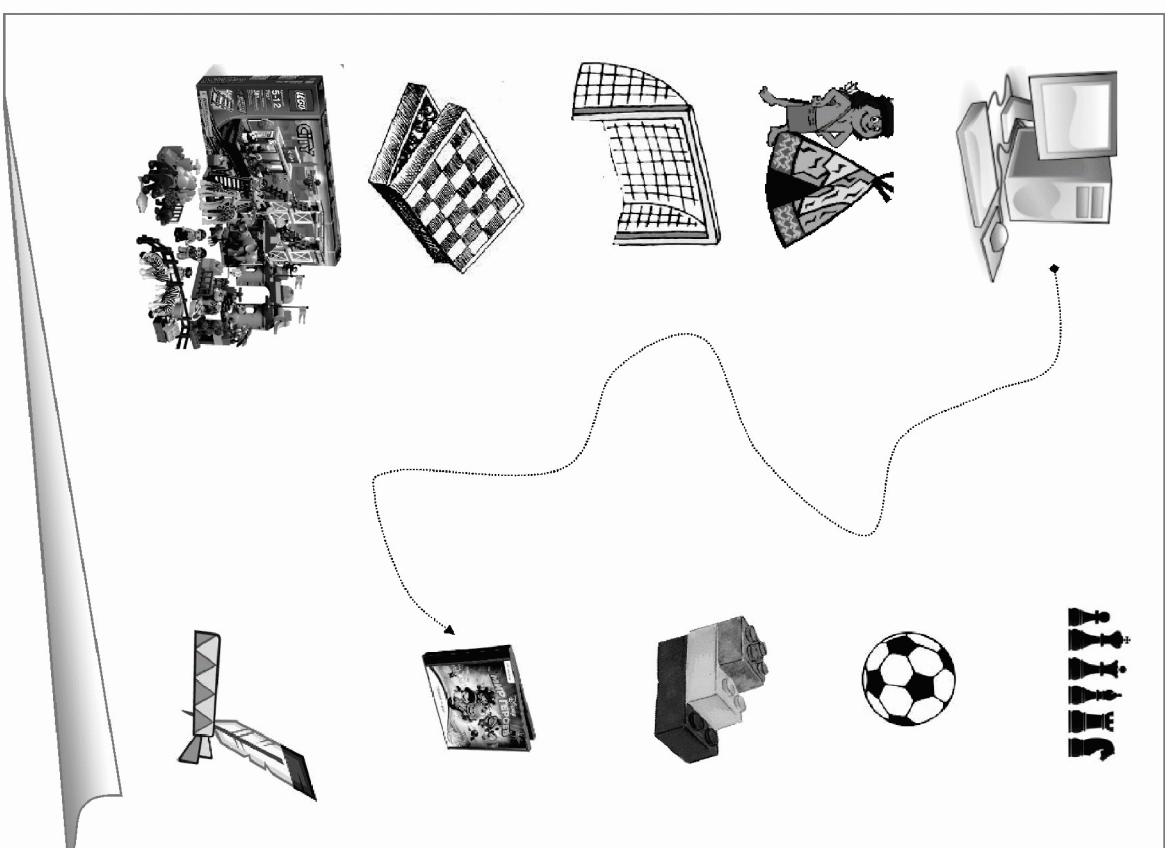



SPIELZEUGE



SPIELZEUGE

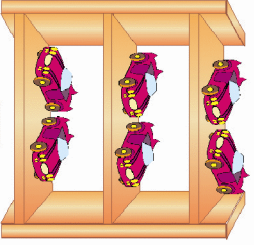
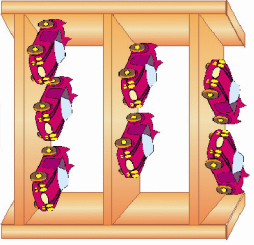
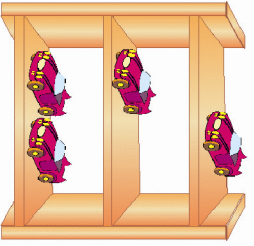
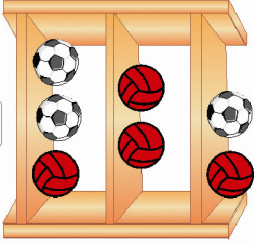
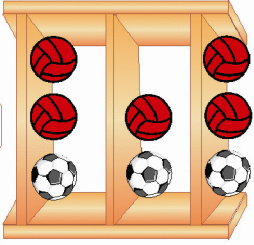
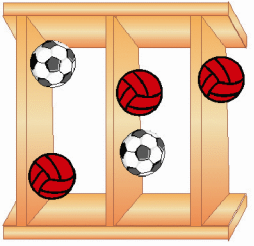
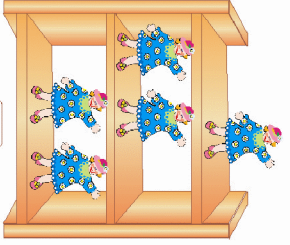
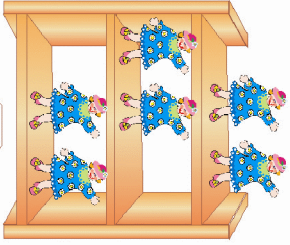
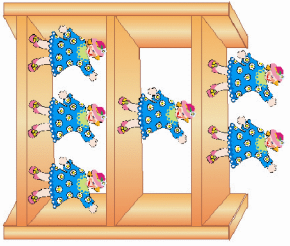



UMWELT
Bekannschaft mit Natur

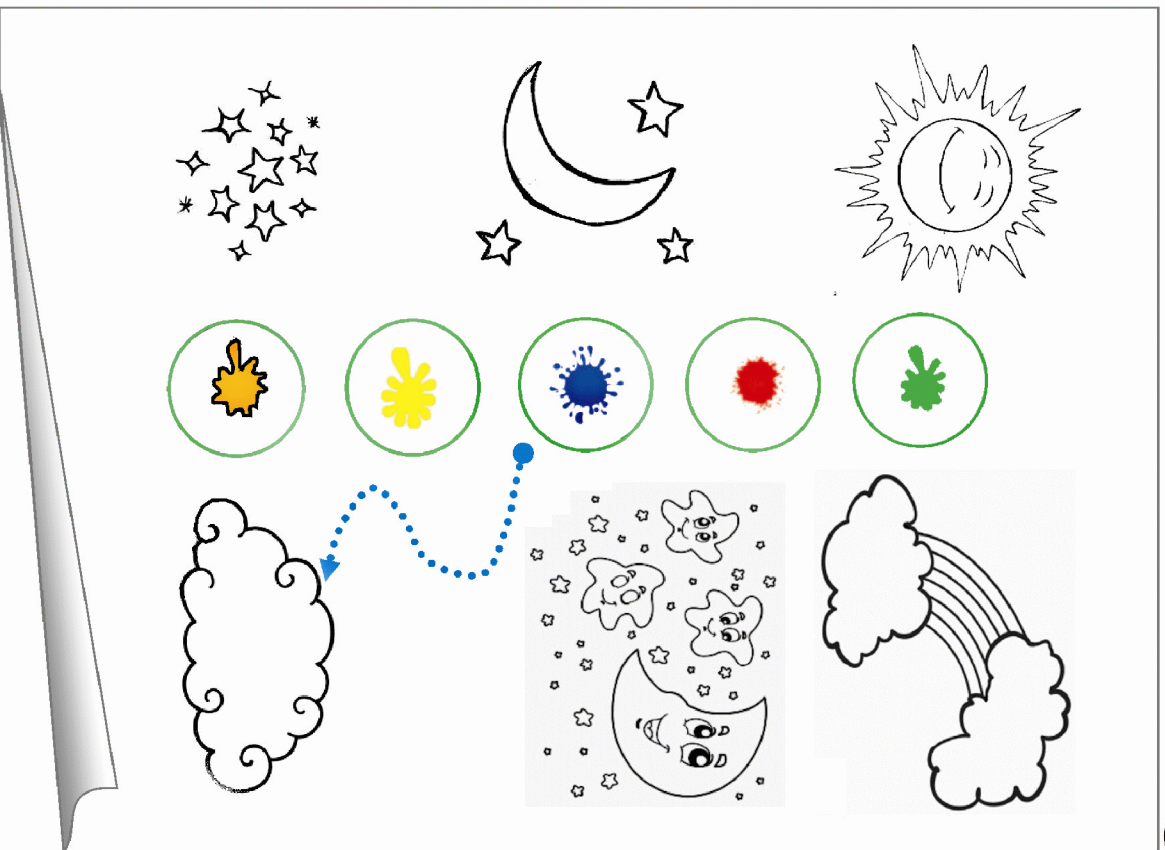
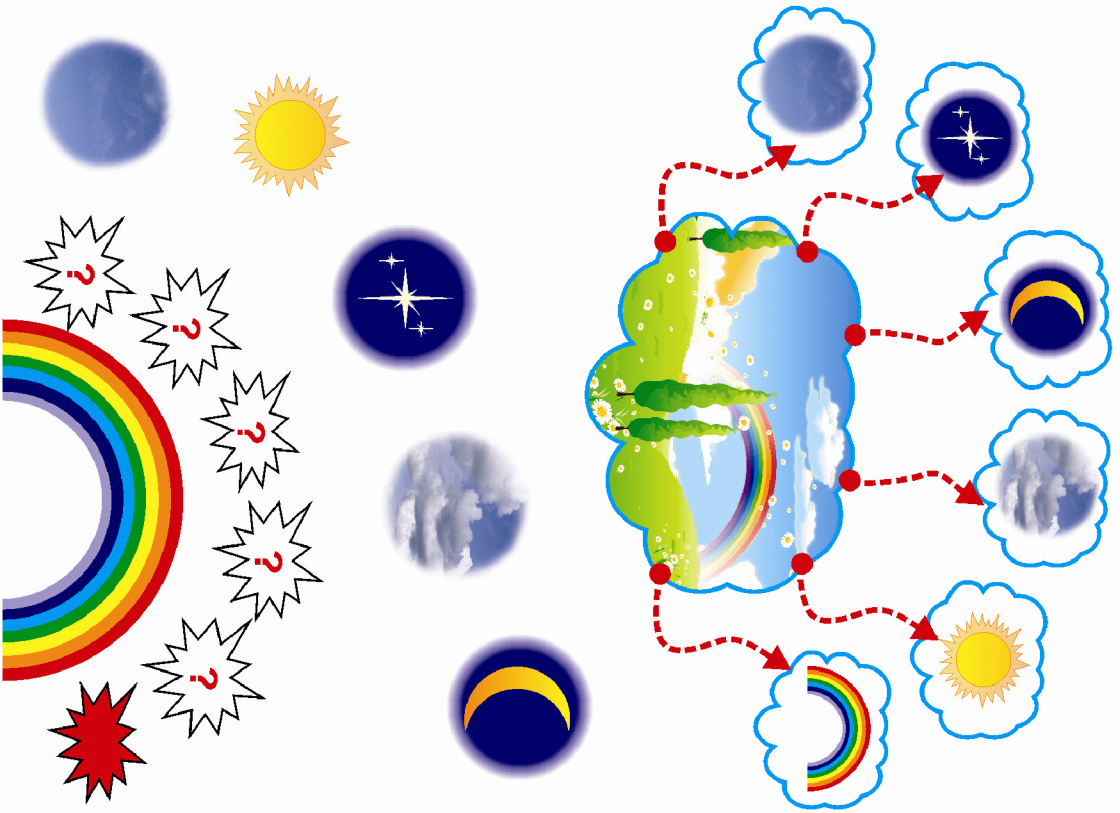

UMWELT
Bekannschaft mit Natur



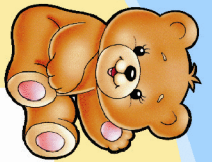

UMWELT

Bekannschaft mit Natur



UMWELT

Bekannschaft mit Natur

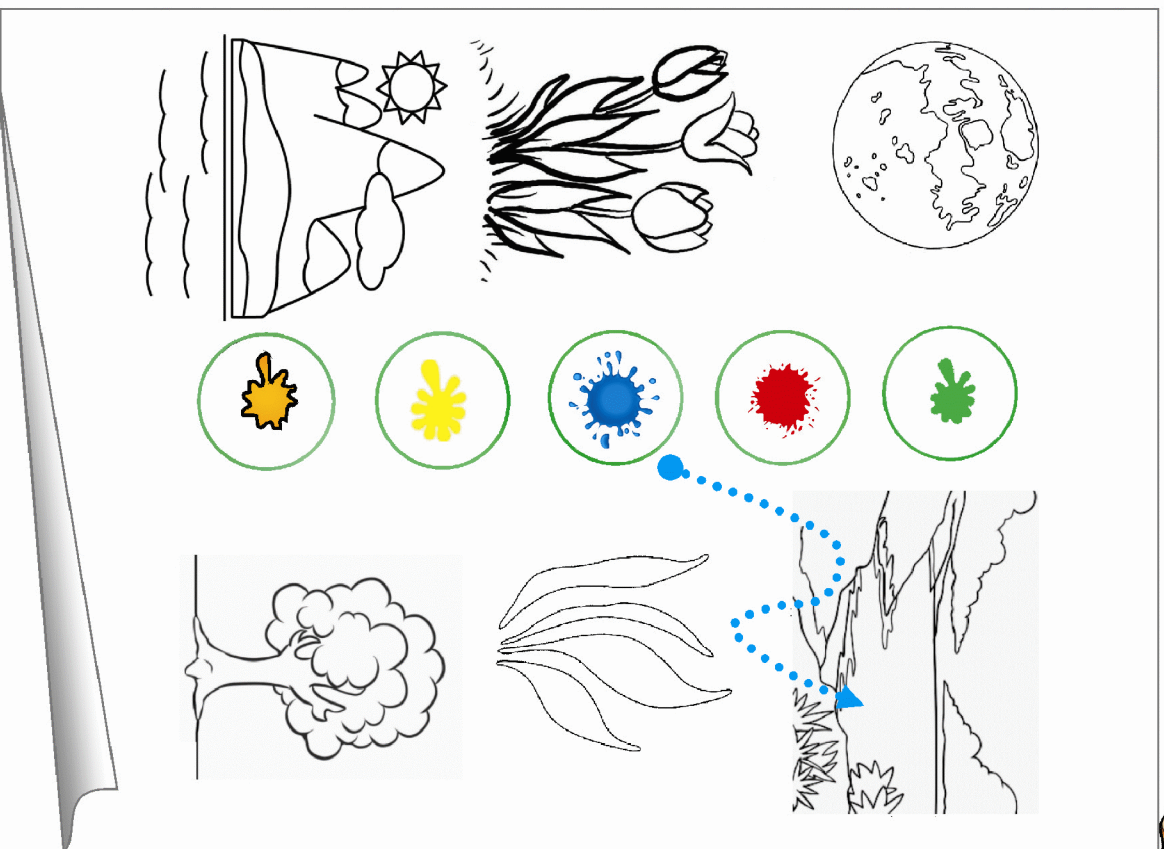



UMWELT
Jahreszeiten

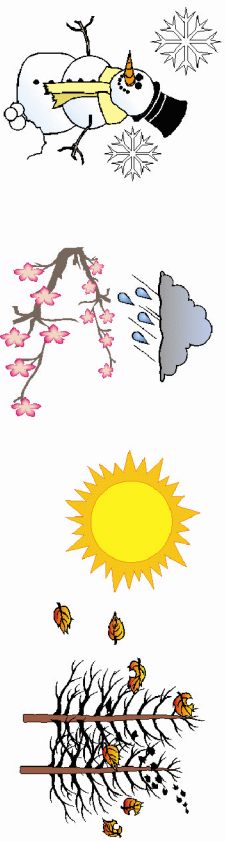
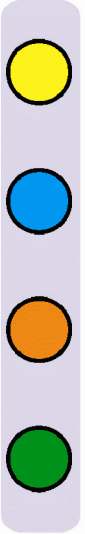

UMWELT
Jahreszeiten

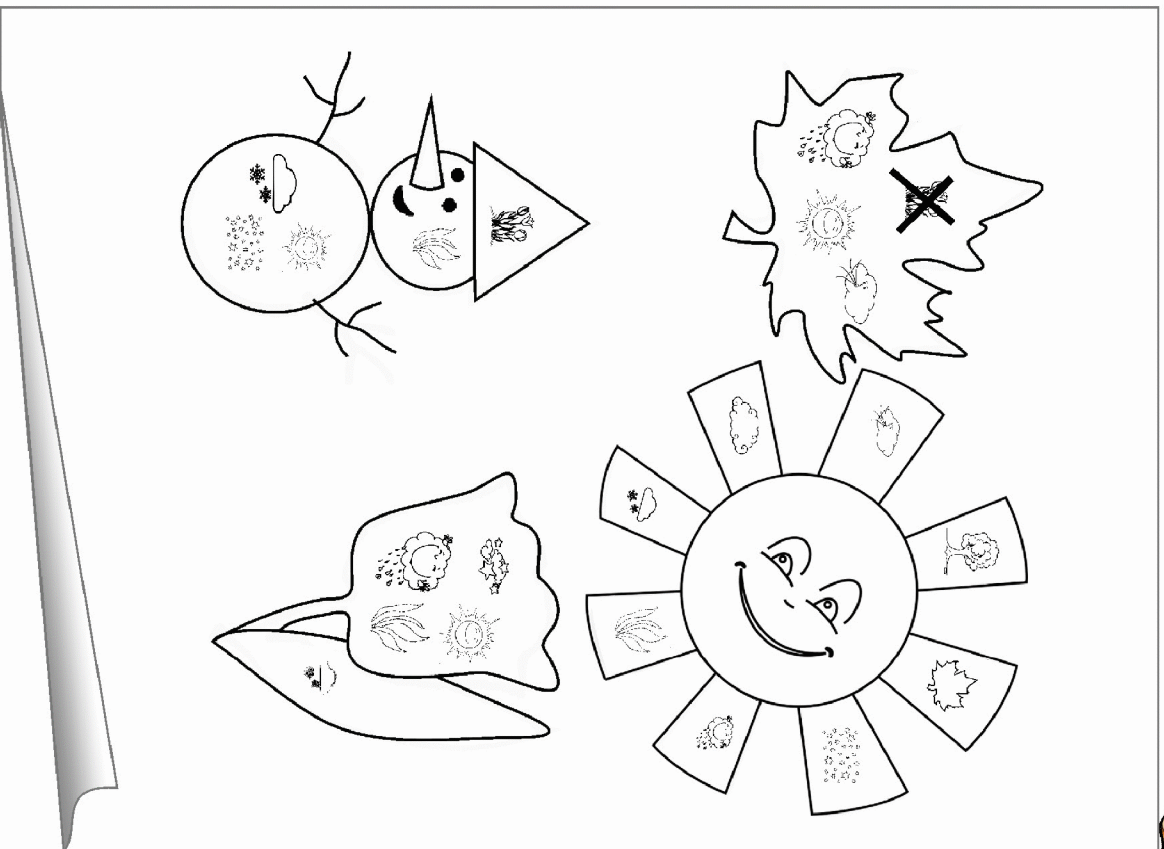



UMWELT
Natur und wir

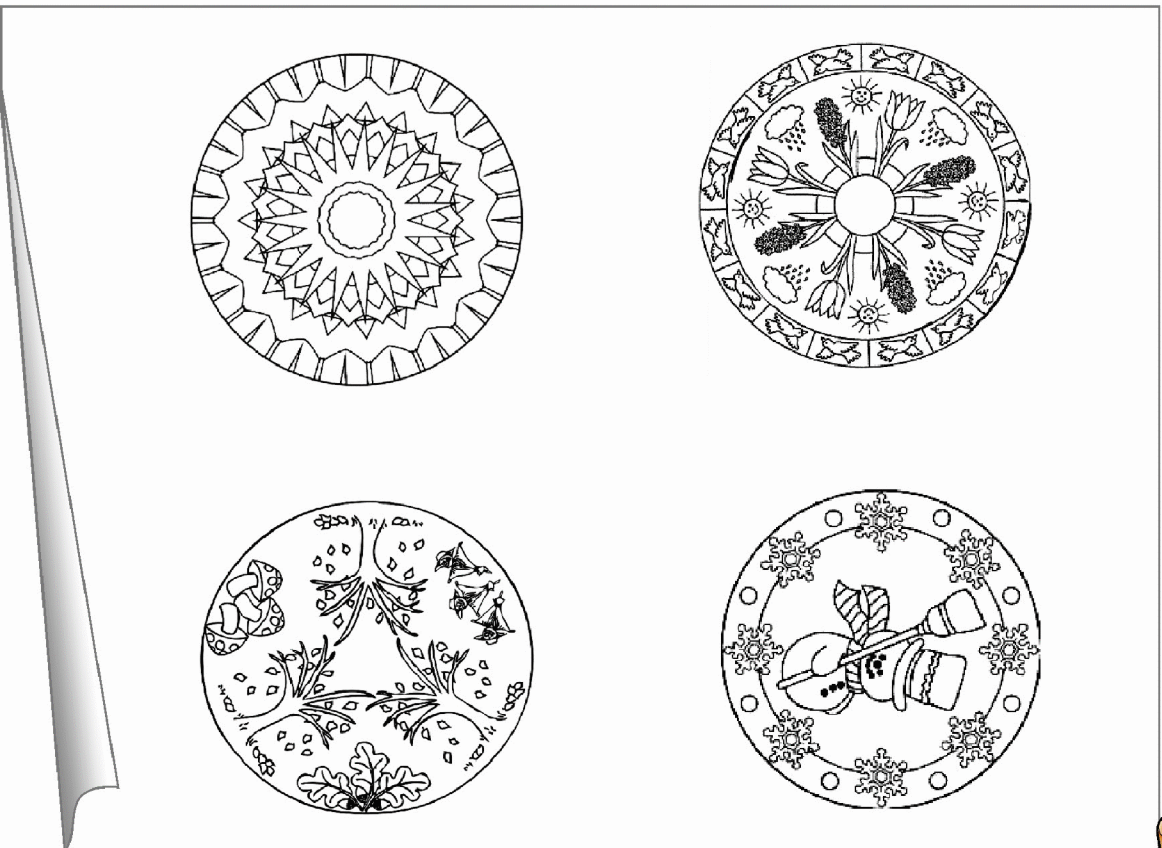
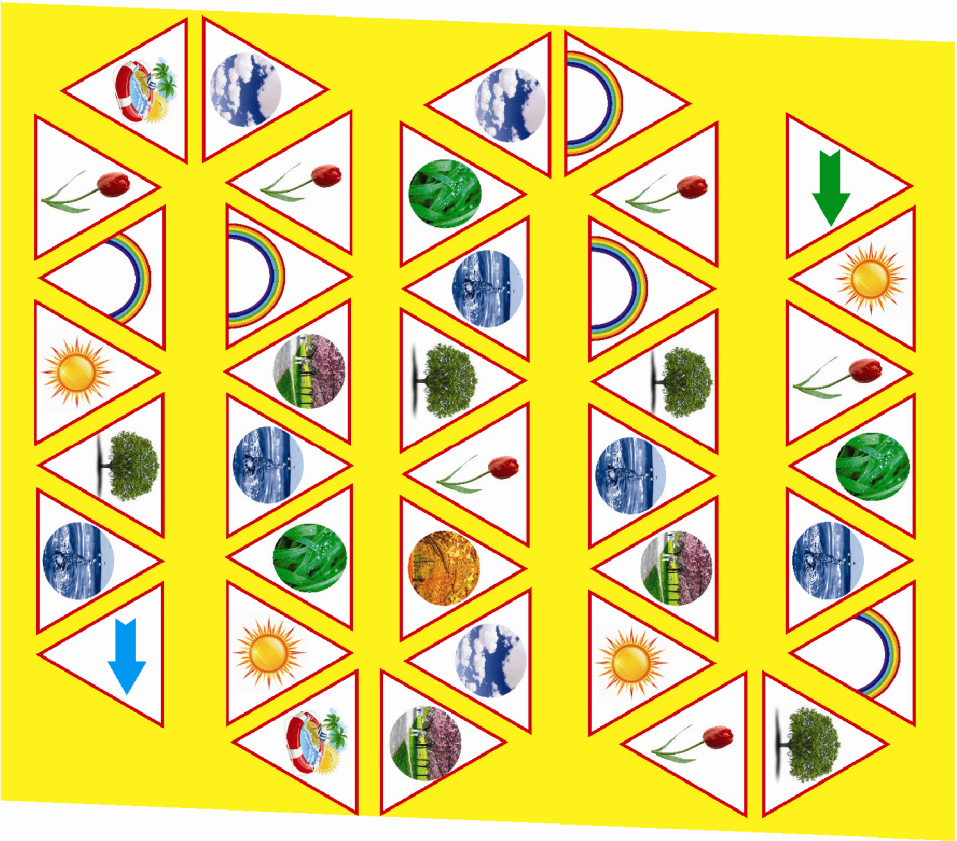

UMWELT
Natur und wir





KÖRPERTEILE

Was ist das?

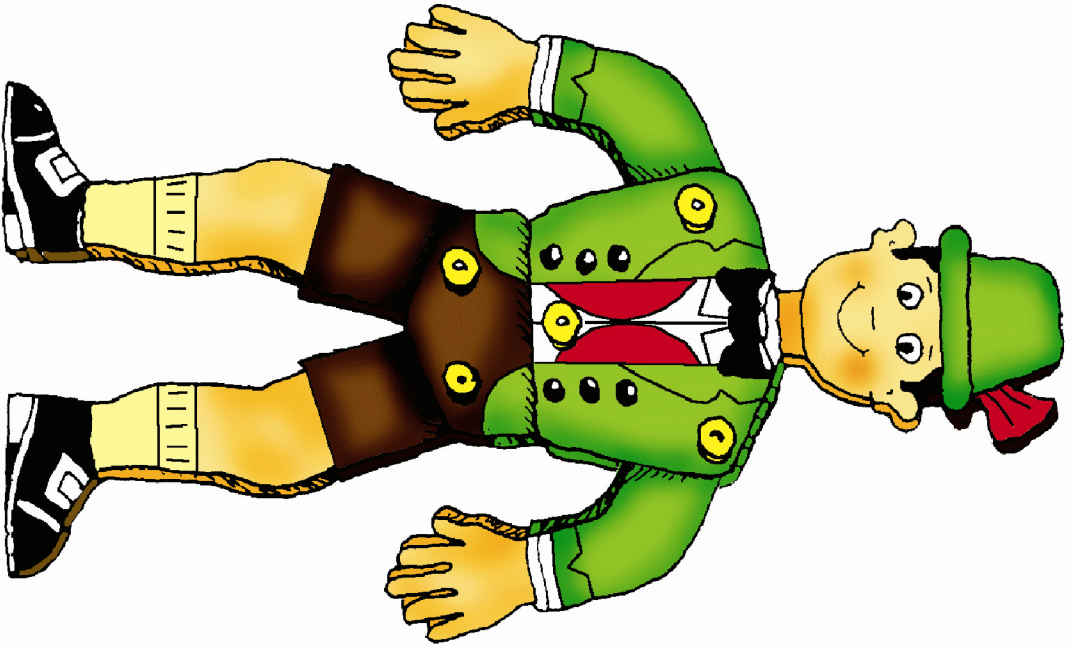

KÖRPERTEILE

Was ist das?



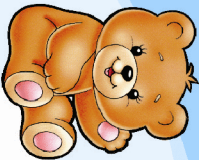

KÖRPERTEILE

Mein Hampelmann

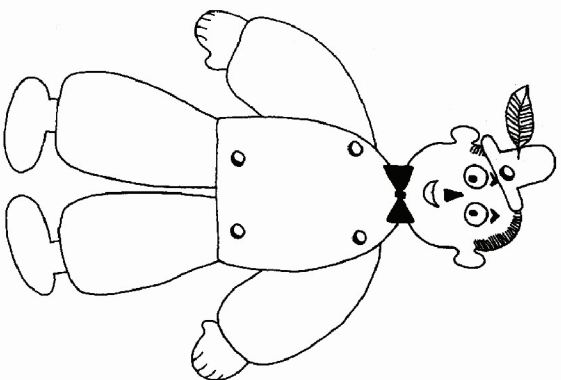
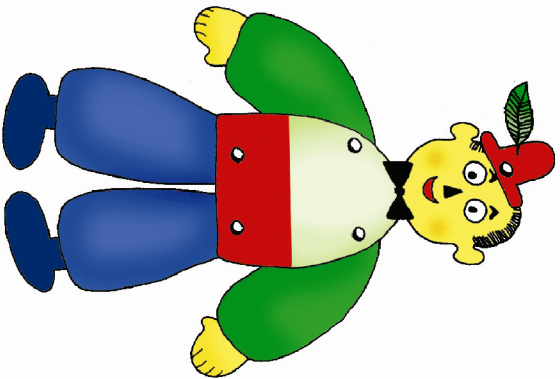

KÖRPERTEILE

Mein Hampelmann

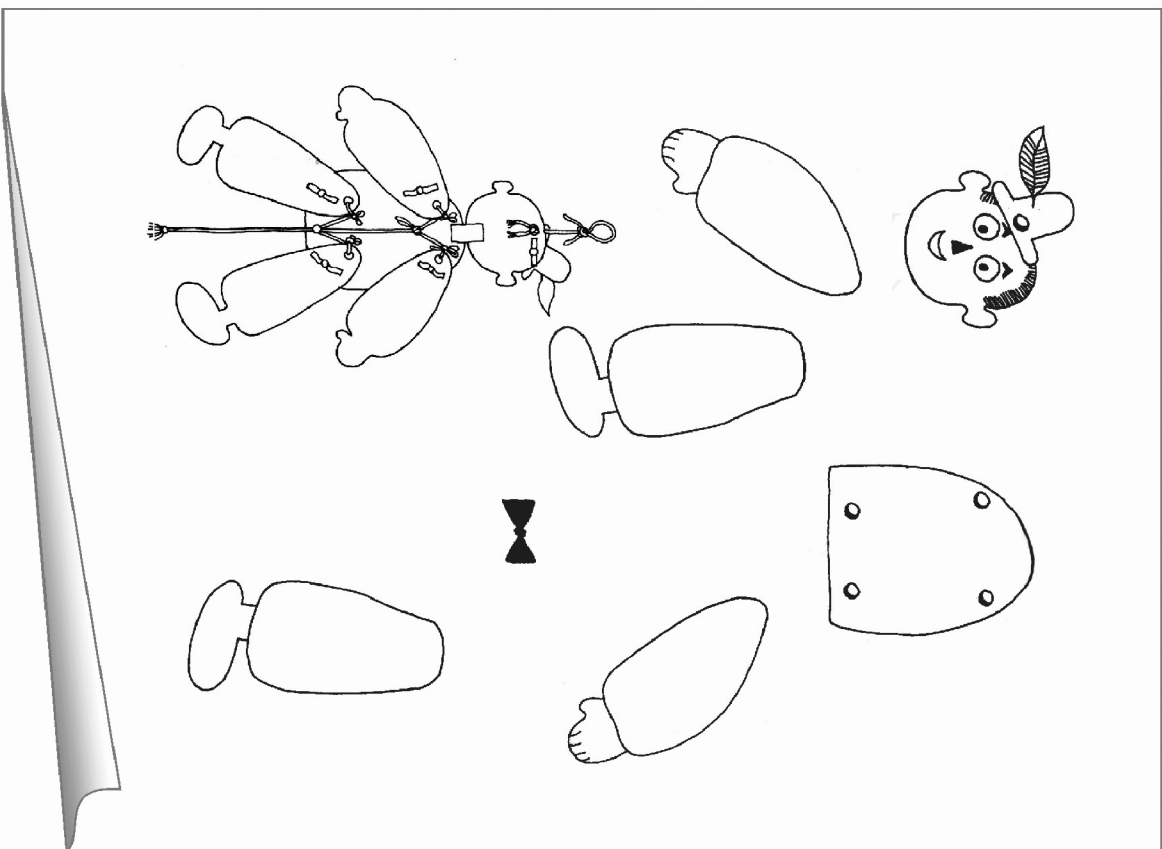

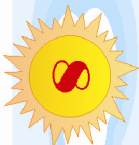

KÖRPERTEILE

Am Morgen

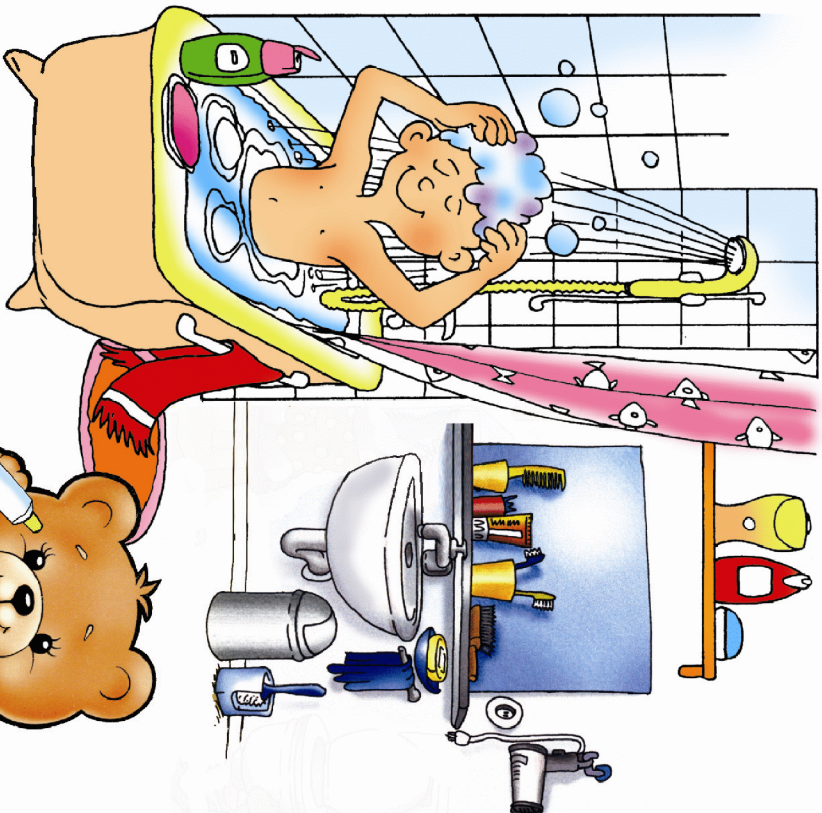

KÖRPERTEILE

Am Morgen

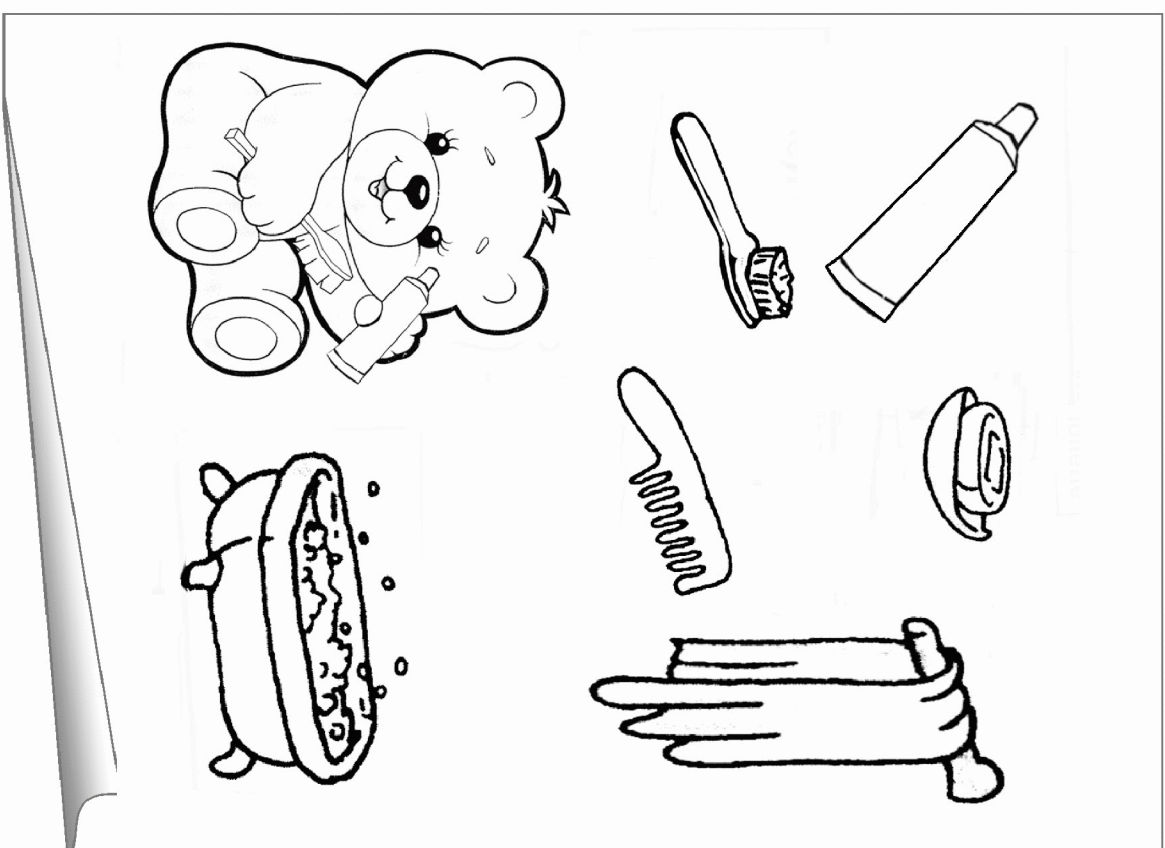

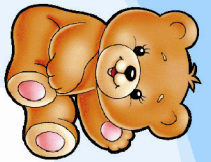

KÖRPERTEILE

Was tut weh?

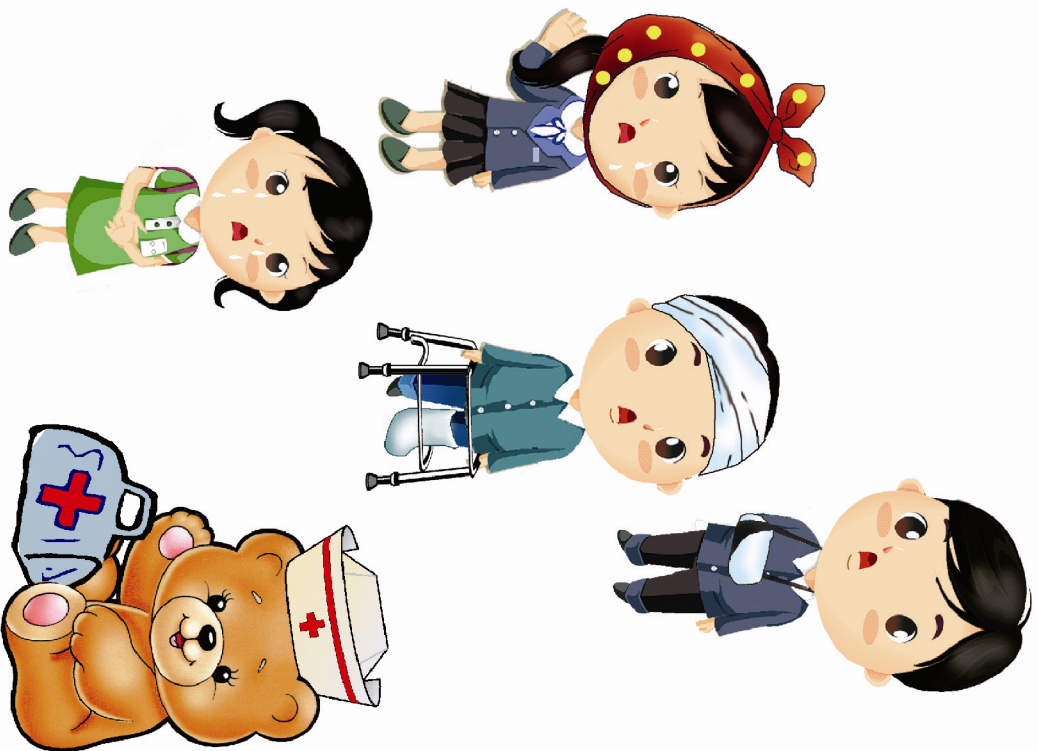

KÖRPERTEILE

Was tut weh?

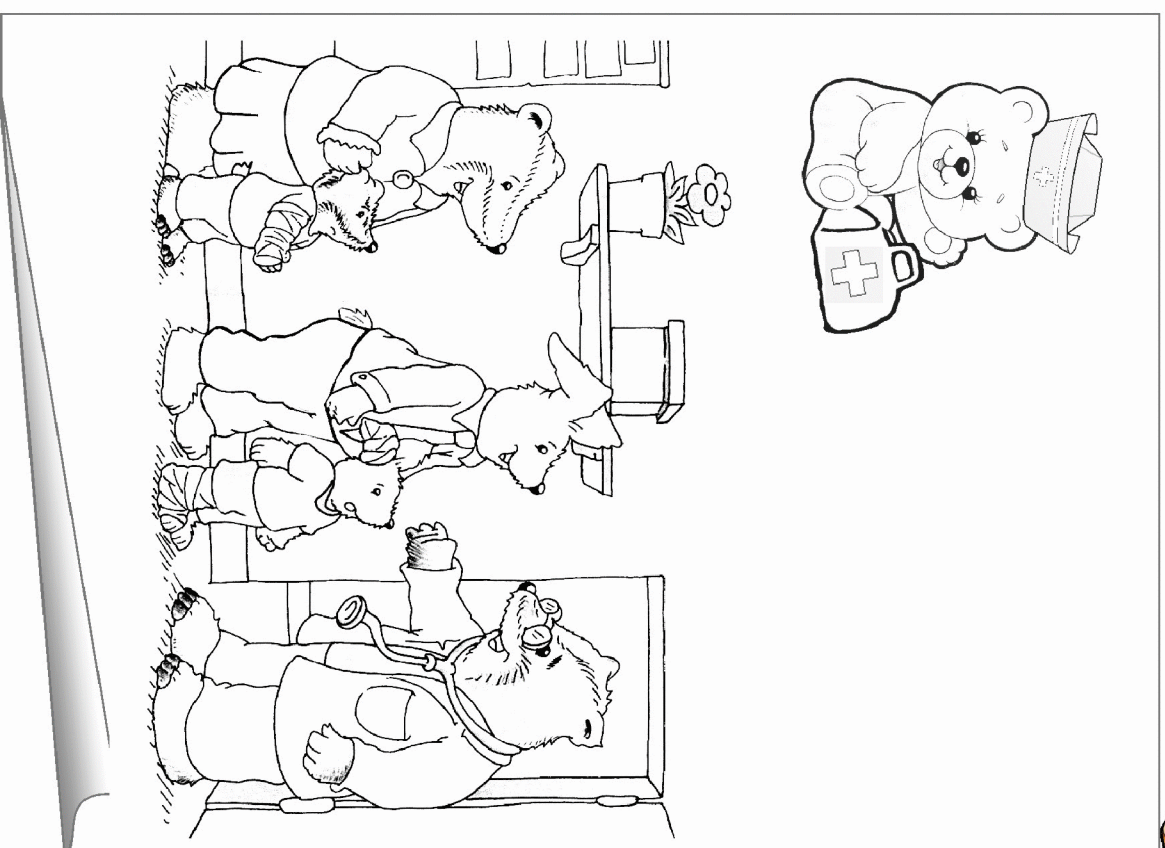



MEIN KLASSENZIMMER

In der Klasse

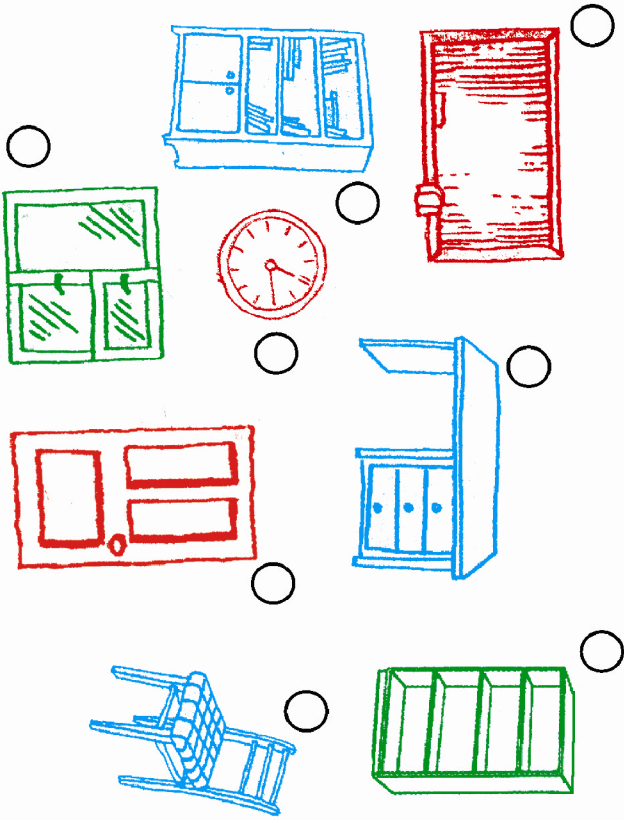
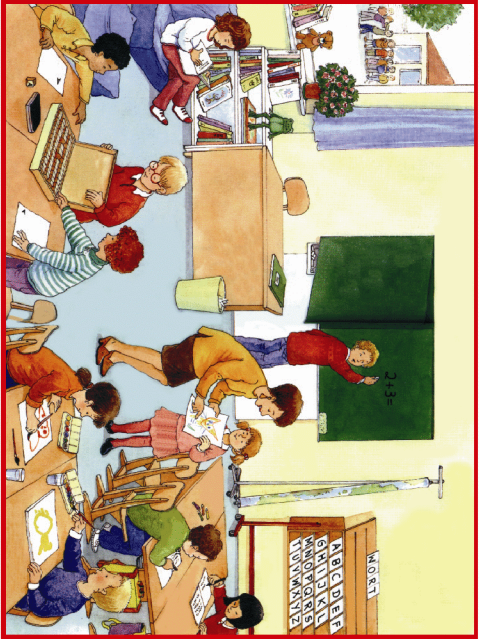

MEIN KLASSENZIMMER

In der Klasse

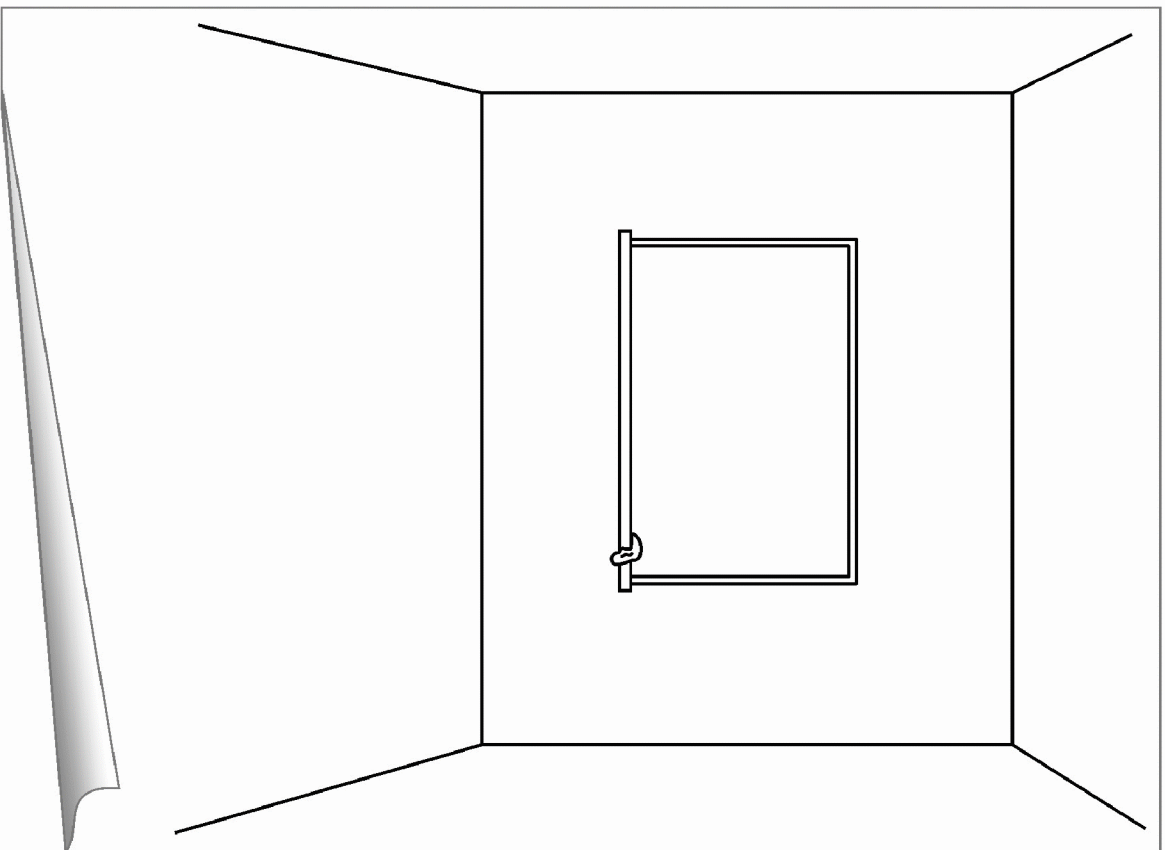



MEIN KLASSENZIMMER

Meine Schulsachen

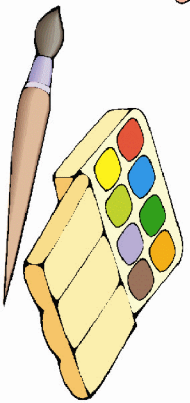
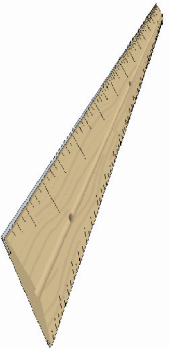
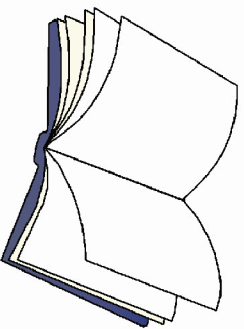
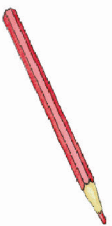
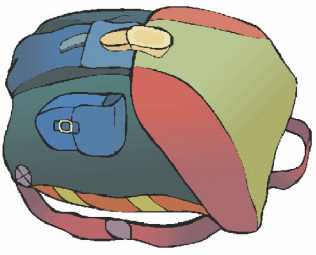

MEIN KLASSENZIMMER

Meine Schulsachen

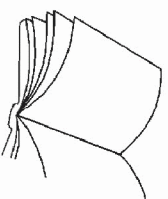
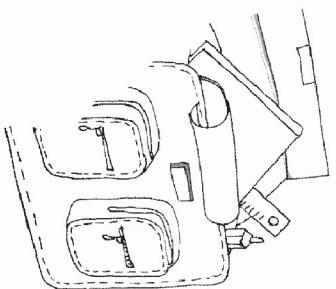
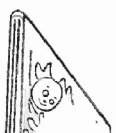
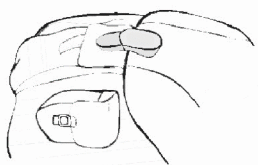



MEIN KLASSENZIMMER

Mer hat was?

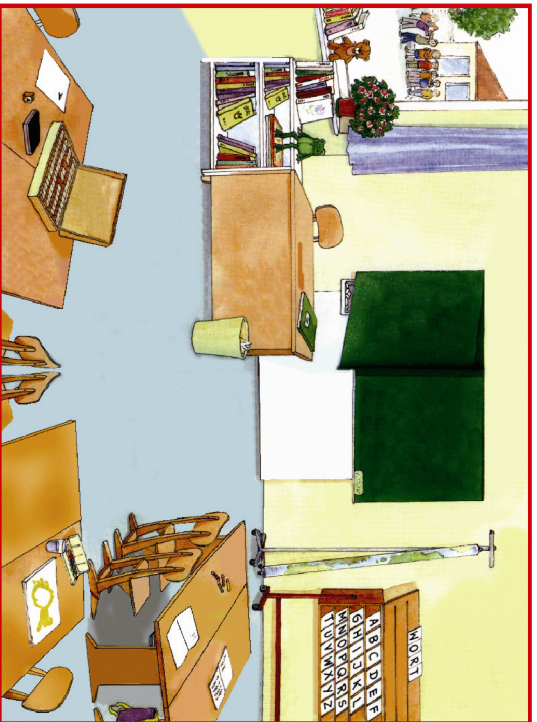
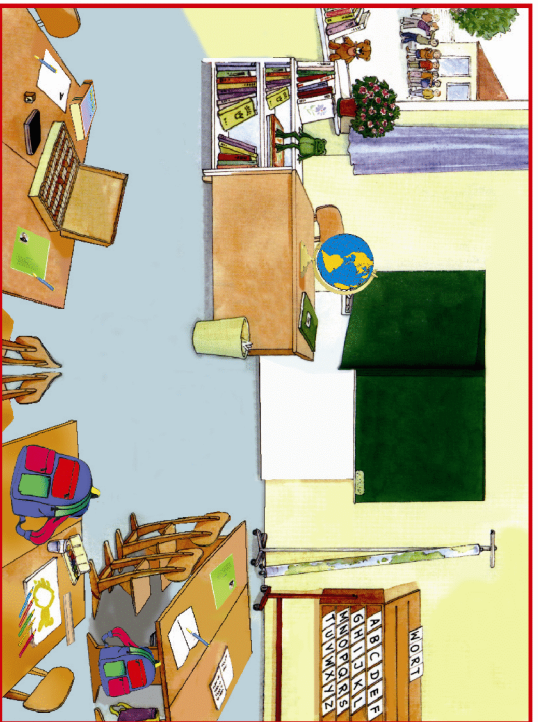

MEIN KLASSENZIMMER

Mer hat was?

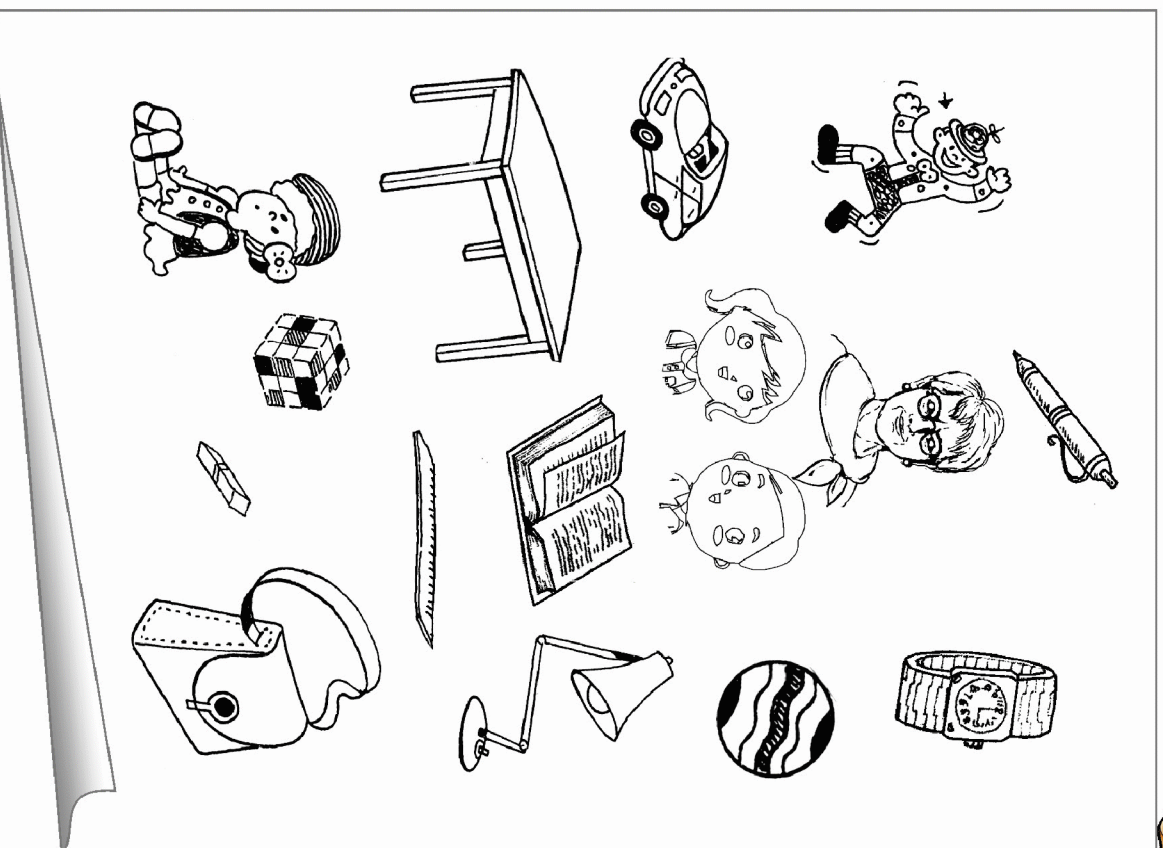

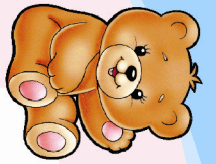

MEIN KLASSENZIMMER

Was habe ich in meiner Schultasche?



MEIN KLASSENZIMMER

Was habe ich in meiner Schultasche?

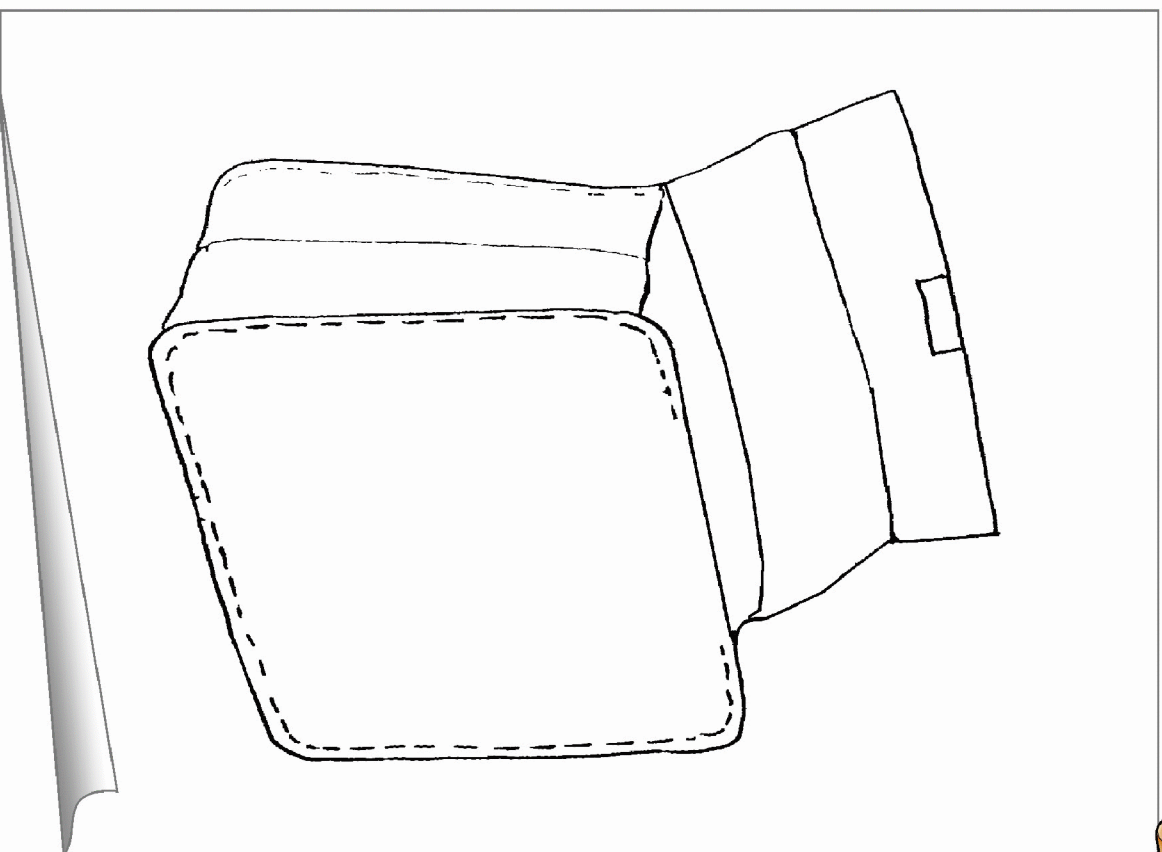



ZAHLEN
Wir zählen (1-10)

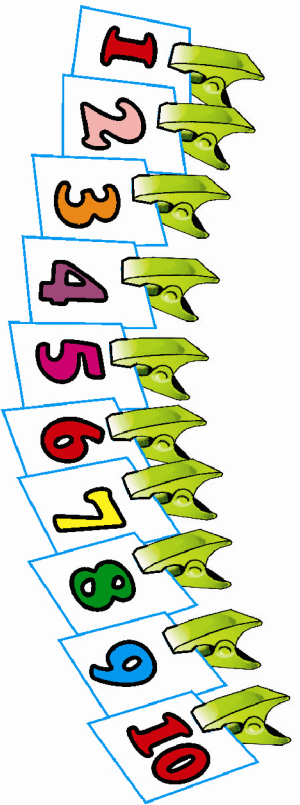

ZAHLEN
Wir zählen (1-10)

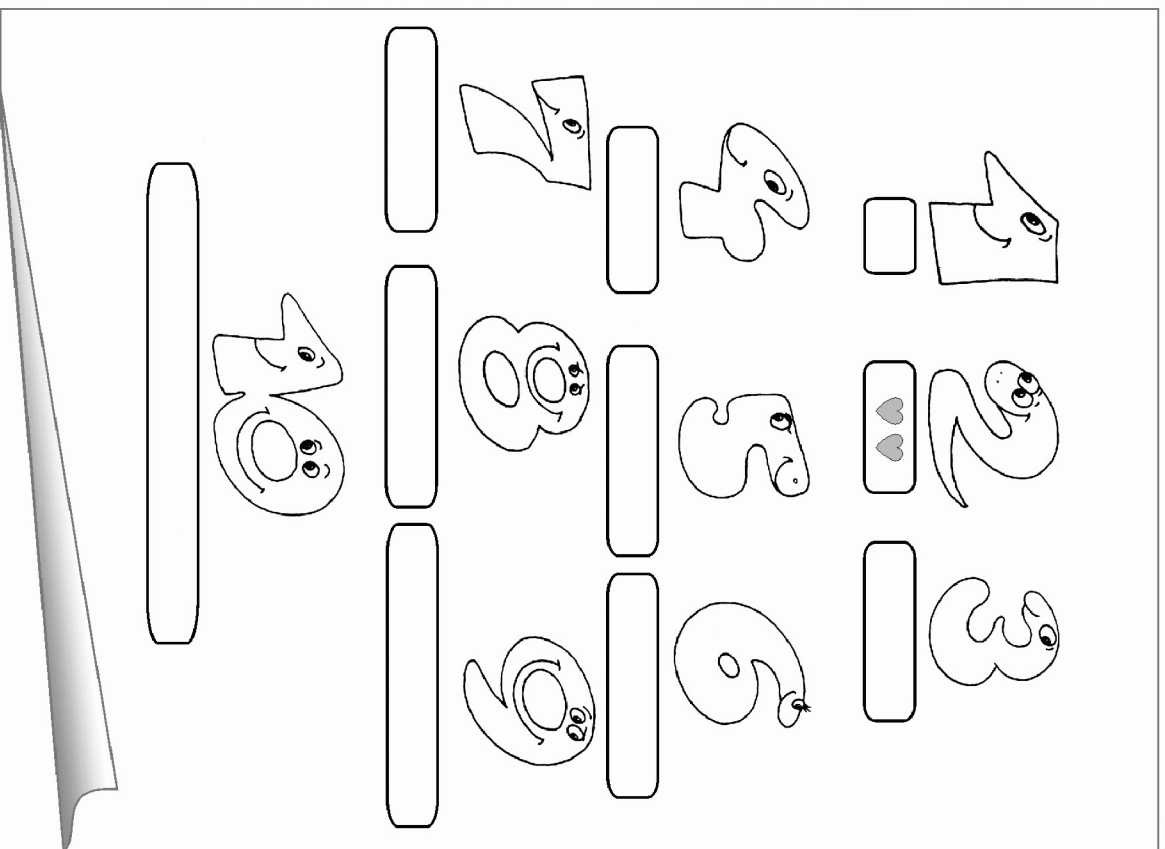



ZAHLEN
Wir zählen (11-20)

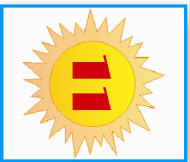

ZAHLEN
Wir zählen (11-20)



A large rectangular area containing various counting exercises. At the top, there are three boxes of fruit: one with 10 apples, one with 4 bananas, and one with 2 strawberries. Below these are several rows of dot patterns in rectangular boxes, some with lines pointing to the fruit boxes above. At the bottom, there are three boxes of fruit: one with 10 grapes, one with 4 watermelons, and one with 1 pear.





ZAHLEN

Welche Ziffer fehlt?

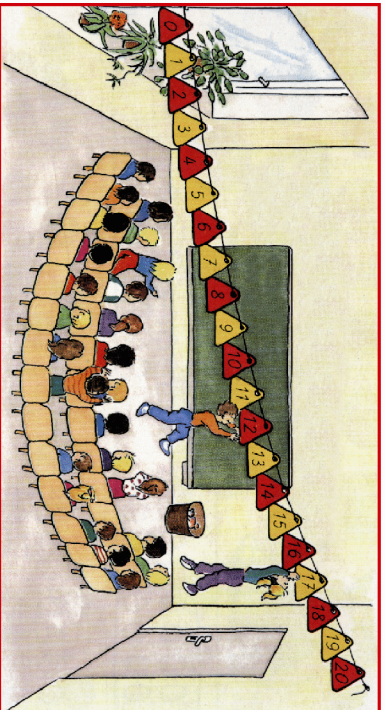

ZAHLEN

Welche Ziffer fehlt?















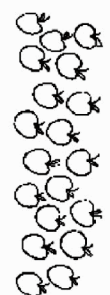

19

15

17

15

19

11

14

13

10	12	7	10	11	20
18	19	14	15	11	13

9	10	6	8	5	6
12	13	14	16	12	13
17	18	18	20	16	17

0	1	6	7	4	5
8	9	3	4	6	7
3	5	1	3	8	10



ZAHLEN
Wir zählen spielend



ZAHLEN
Wir zählen spielend

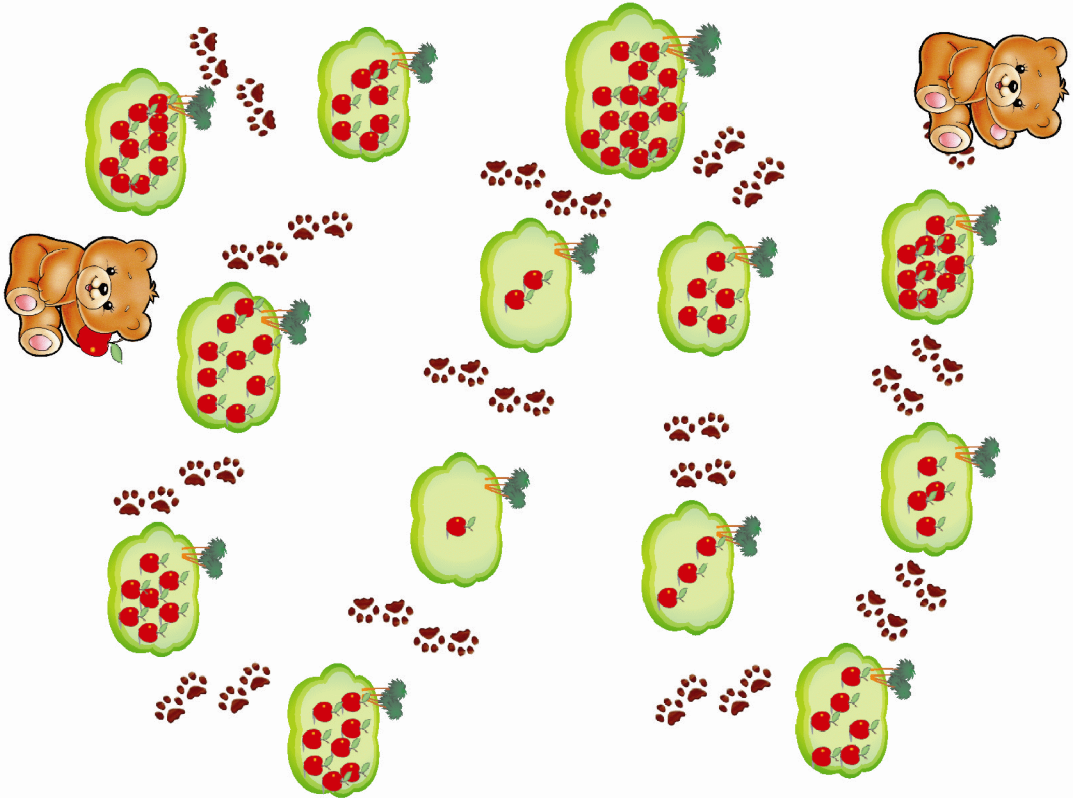

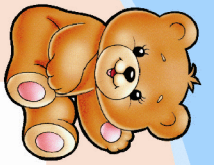

11

OBST UND GEMÜSE

Was ist das?

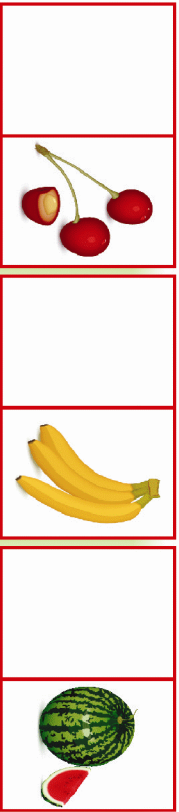
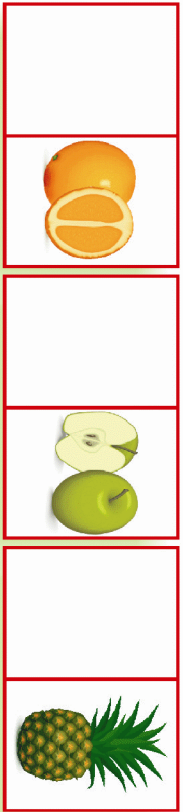
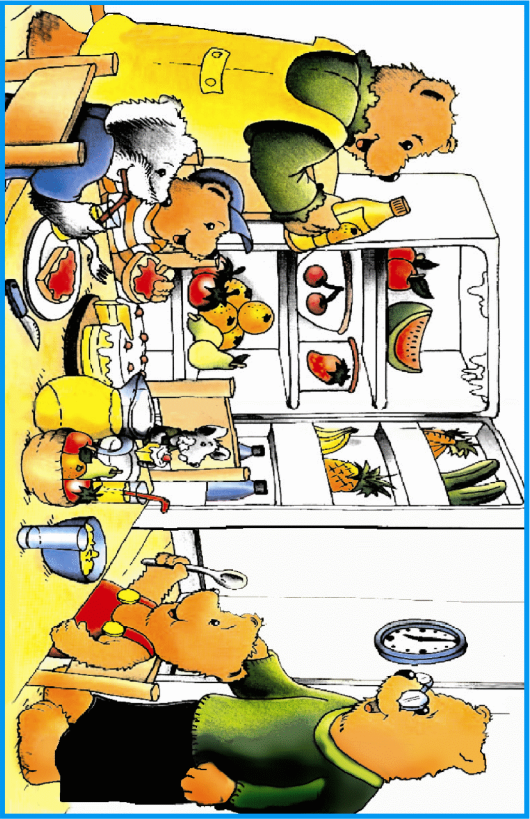

OBST UND GEMÜSE

Was ist das?

11

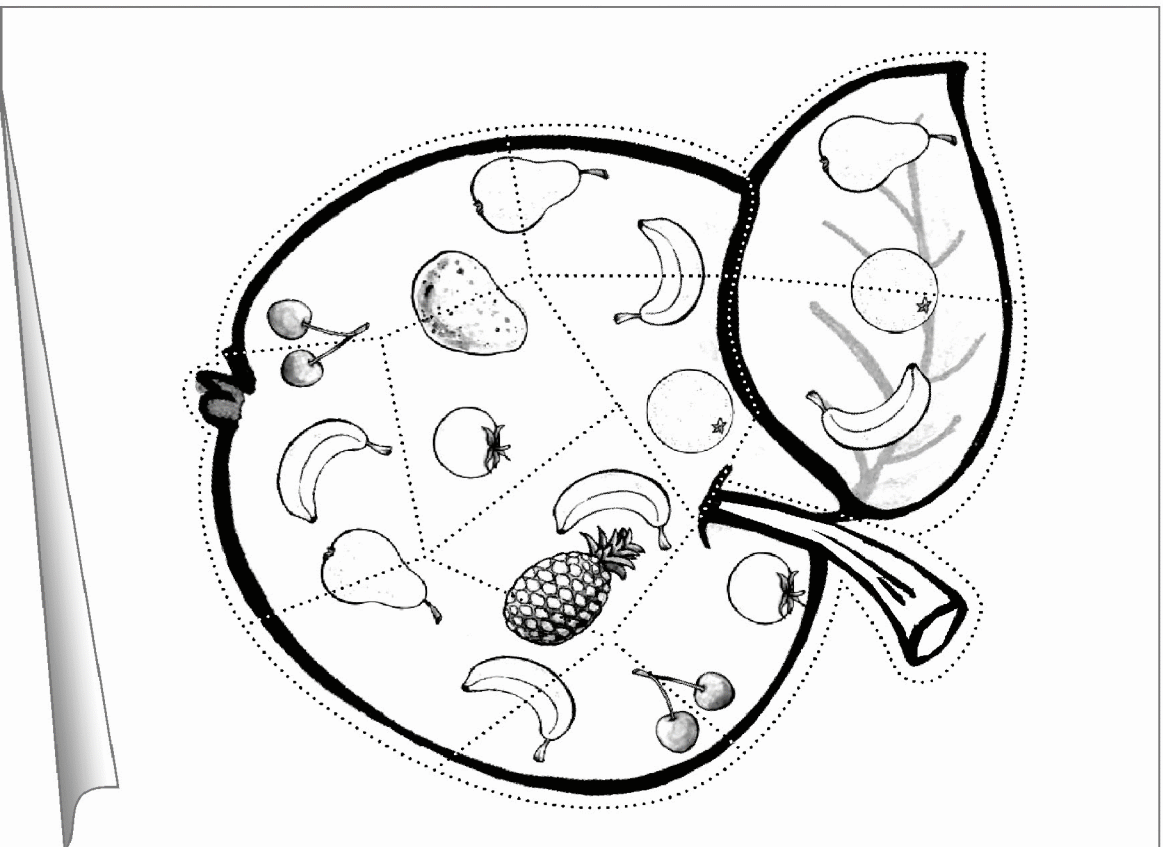

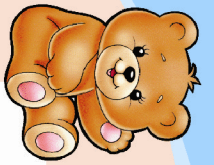

OBST UND GEMÜSE

Nennt Obste und zählt!

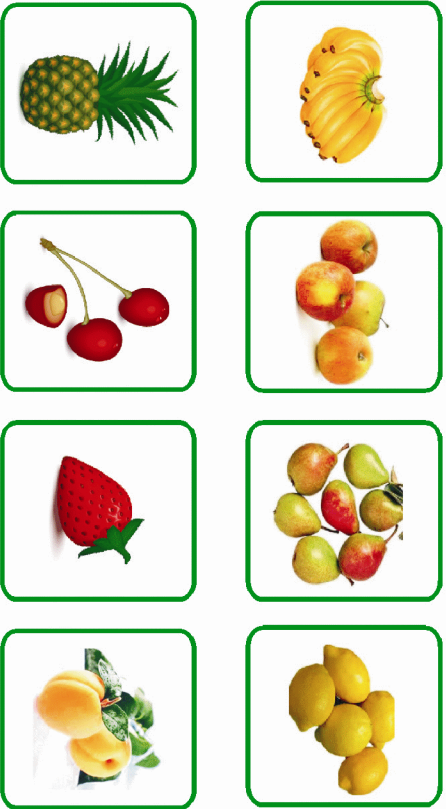
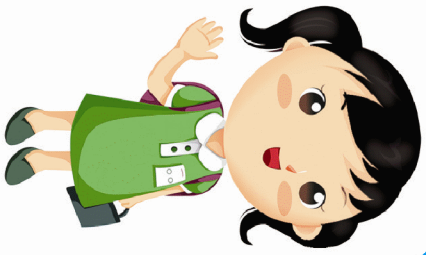

OBST UND GEMÜSE

Nennt Obste und zählt!

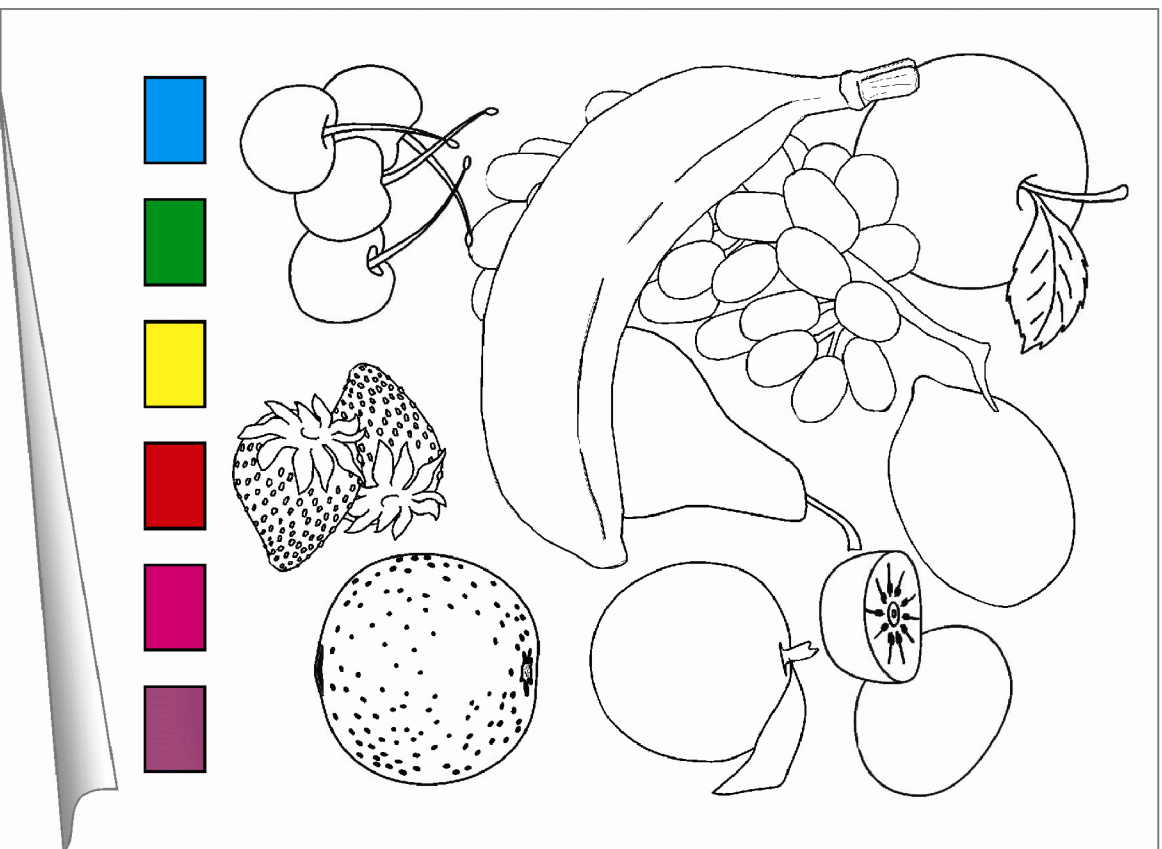

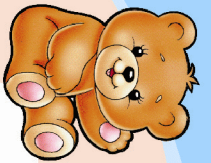







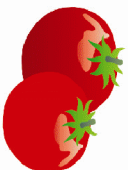

11

OBST UND GEMÜSE

Sortiere Obst und Gemüse!

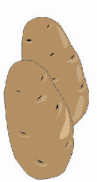

		
		
		



11

OBST UND GEMÜSE

Sortiere Obst und Gemüse!

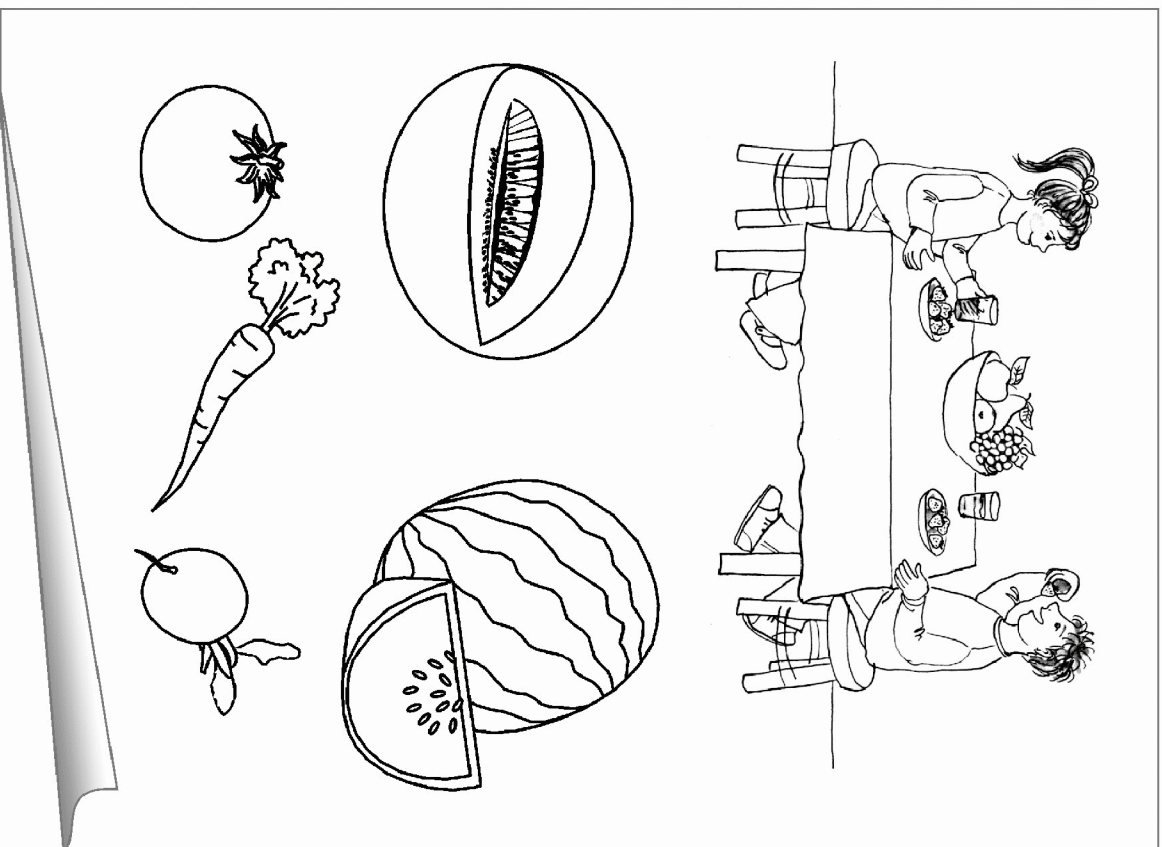

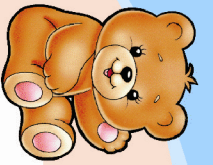











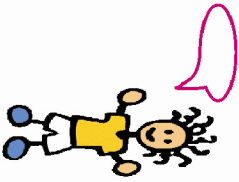

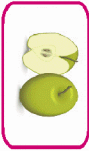
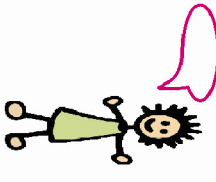

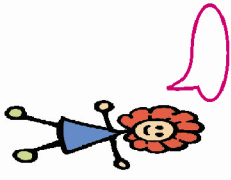

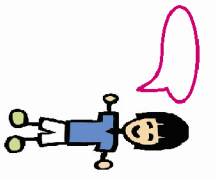
11

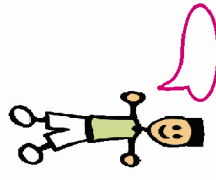
OBST UND GEMÜSE
Spiele

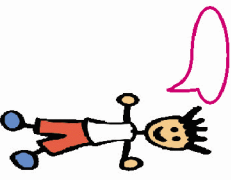

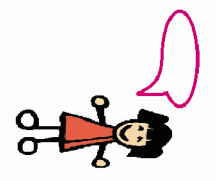
11

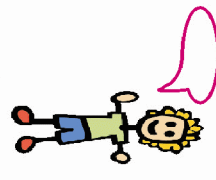
OBST UND GEMÜSE
Spiele

					
					
					





12

TIERE
Haustiere

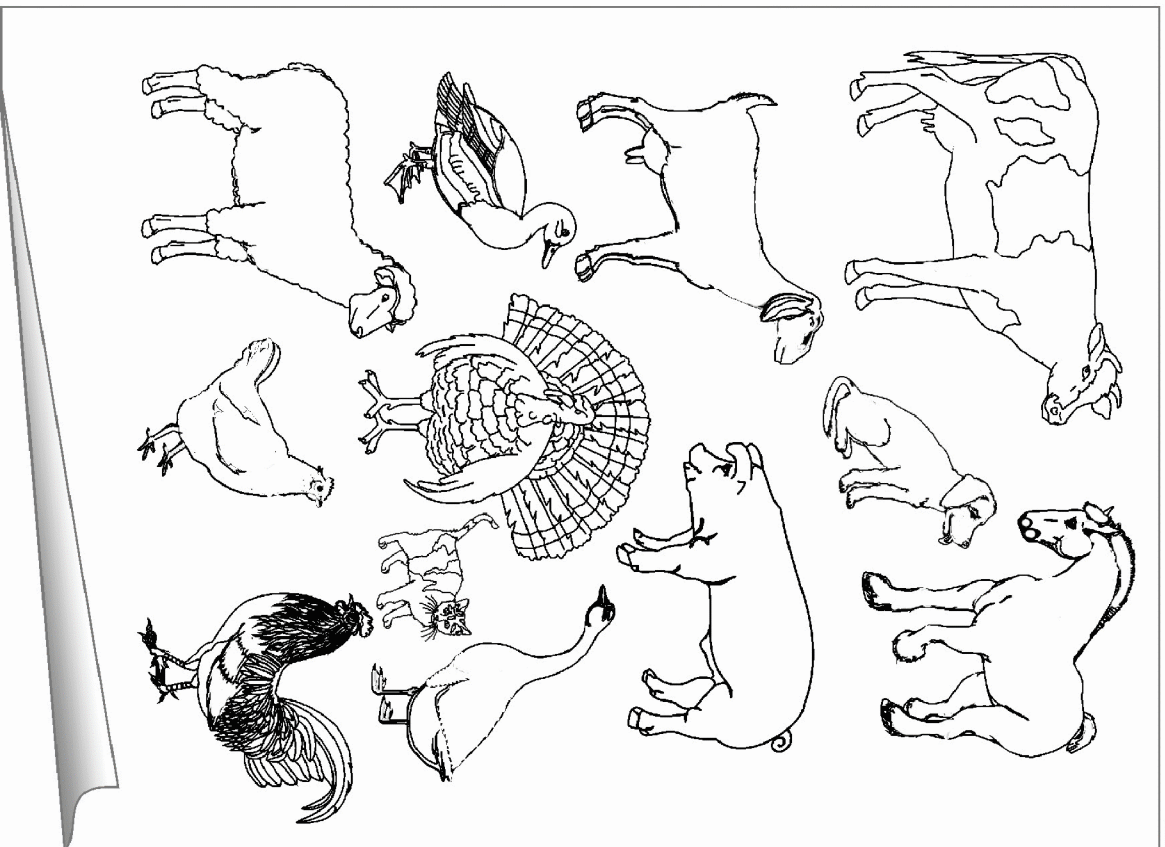

TIERE
Haustiere

12





12

TIERE
Wildtiere

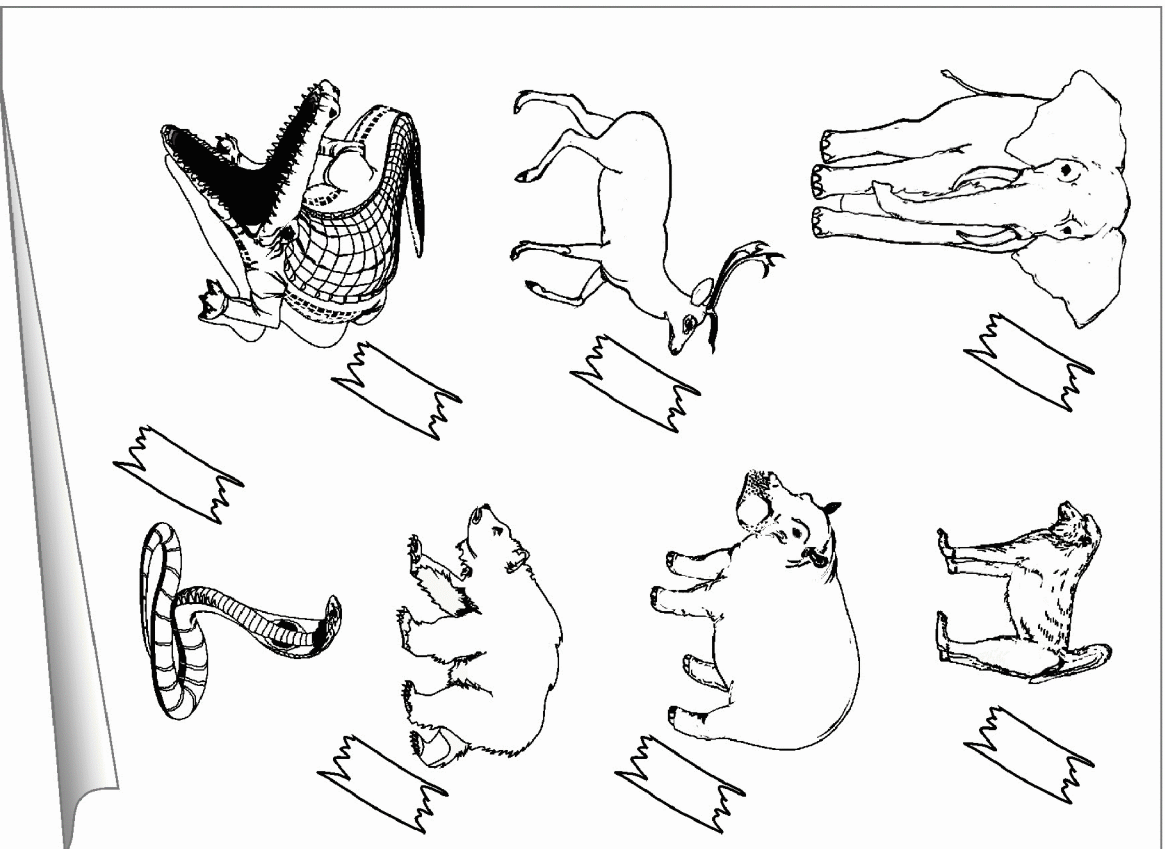
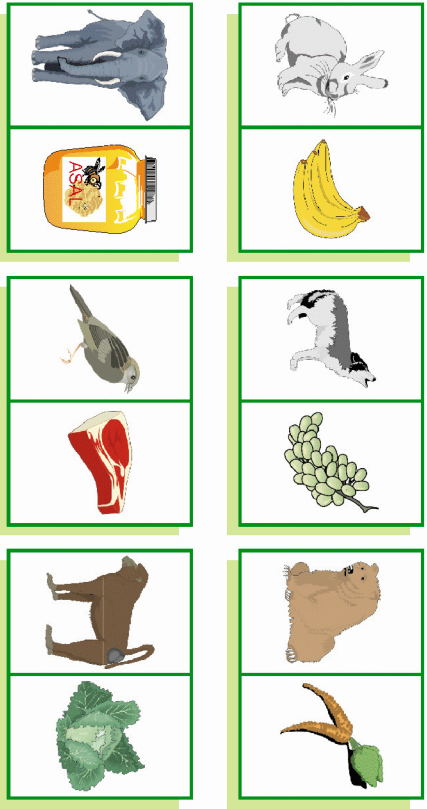

TIERE
Wildtiere

12





12

TIERE
Wie ist die Katze?

12

TIERE
Wie ist die Katze?

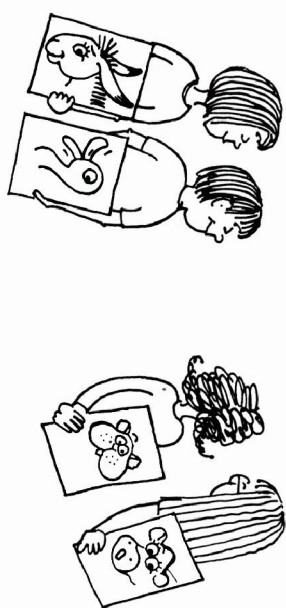
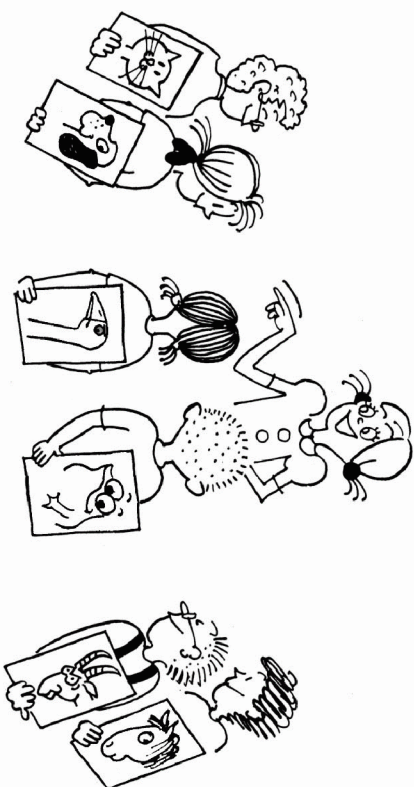
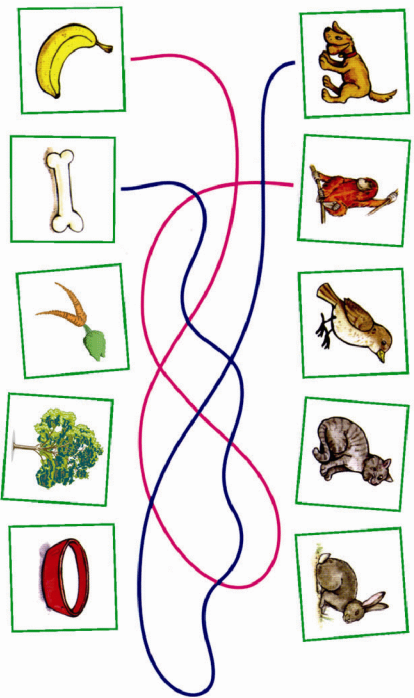
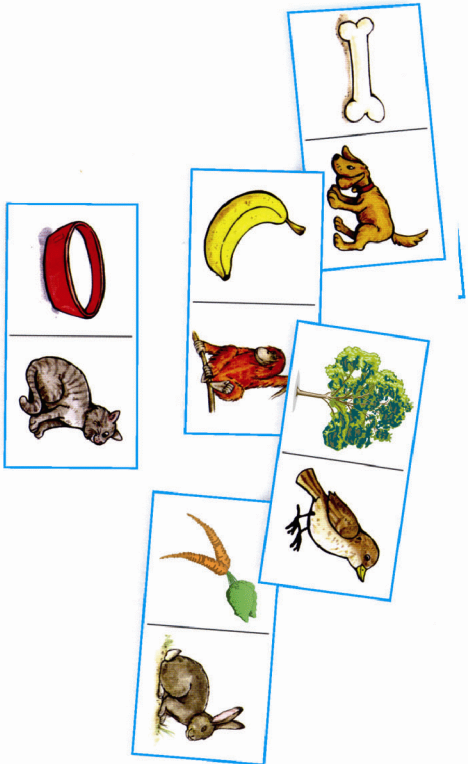



12

TIERE
Ich spiele gern...

Illustration of a boy in a blue suit in the center, surrounded by 12 animal cards, each with a die icon indicating a count:

- 1 sheep (blue background, 1 die)
- 1 butterfly (red background, 2 dice)
- 1 rabbit (green background, 5 dice)
- 1 dog (yellow background, 3 dice)
- 1 horse (blue background, 1 die)
- 1 owl (yellow background, 3 dice)
- 1 mouse (purple background, 4 dice)
- 1 elephant (yellow background, 3 dice)
- 1 donkey (purple background, 1 die)
- 1 lion (green background, 5 dice)
- 1 snake (green background, 5 dice)
- 1 cat (yellow background, 2 dice)
- 1 turtle (blue background, 4 dice)
- 1 bee (red background, 5 dice)



12

TIERE
Ich spiele gern...

Illustration of a boy in a blue suit in the center, surrounded by 8 animal cards, each with a die icon indicating a count:

- 1 sheep (blue background, 1 die)
- 1 butterfly (red background, 2 dice)
- 1 rabbit (green background, 5 dice)
- 1 dog (yellow background, 3 dice)
- 1 horse (blue background, 1 die)
- 1 owl (yellow background, 3 dice)
- 1 mouse (purple background, 4 dice)
- 1 elephant (yellow background, 3 dice)
- 1 donkey (purple background, 1 die)
- 1 lion (green background, 5 dice)
- 1 snake (green background, 5 dice)
- 1 cat (yellow background, 2 dice)
- 1 turtle (blue background, 4 dice)
- 1 bee (red background, 5 dice)



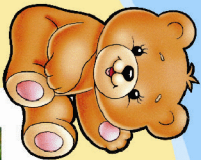

13

MÄRCHENWELT

Kennst du Märchenhelden?



MÄRCHENWELT

Kennst du Märchenhelden?

13

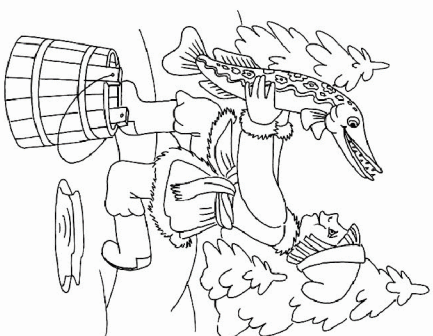

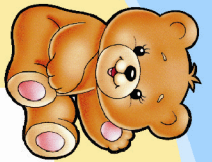

13

MÄRCHENWELT

Sich verabschieden



13

MÄRCHENWELT

Sich verabschieden

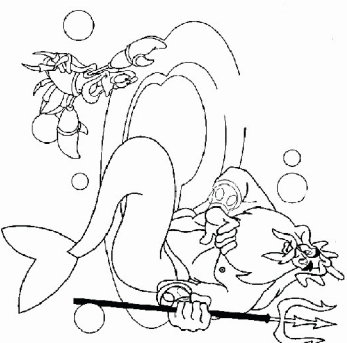
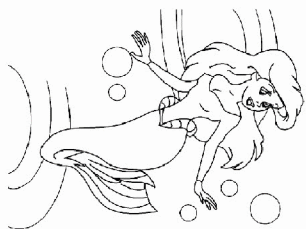



13

MÄRCHENWELT

Wie geht es?

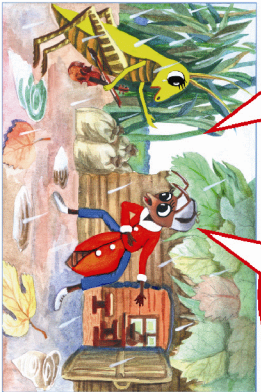

13

MÄRCHENWELT

Wie geht es?

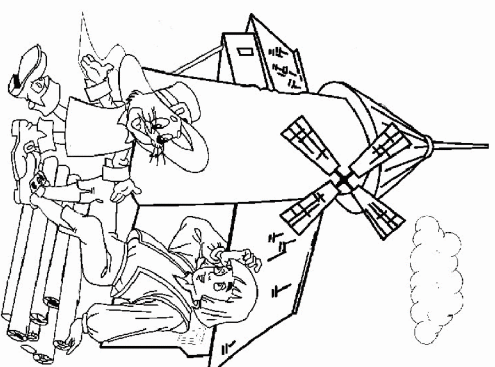
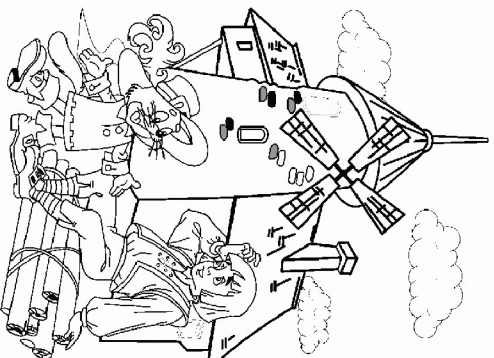

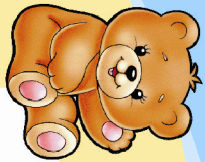

13

MÄRCHENWELT

MÄRCHENWELT

13

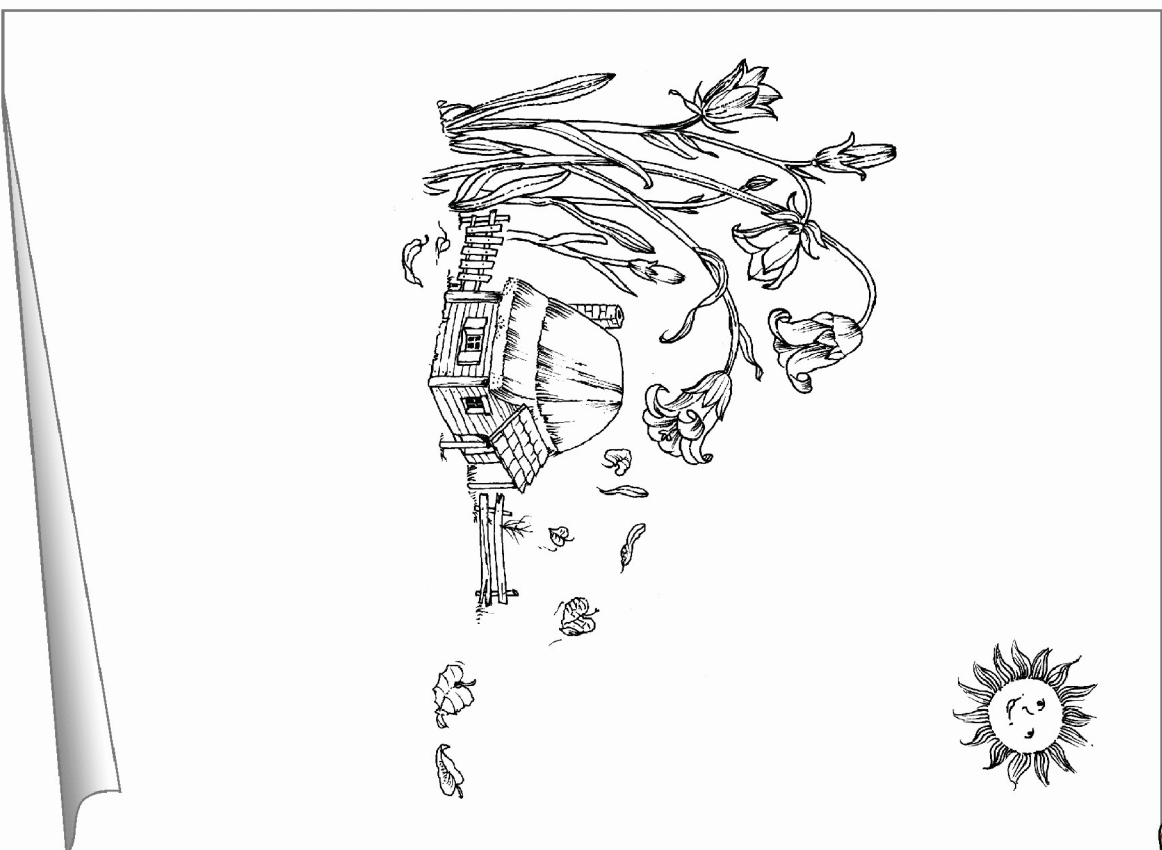



WAS KANN ICH... Zu Hause

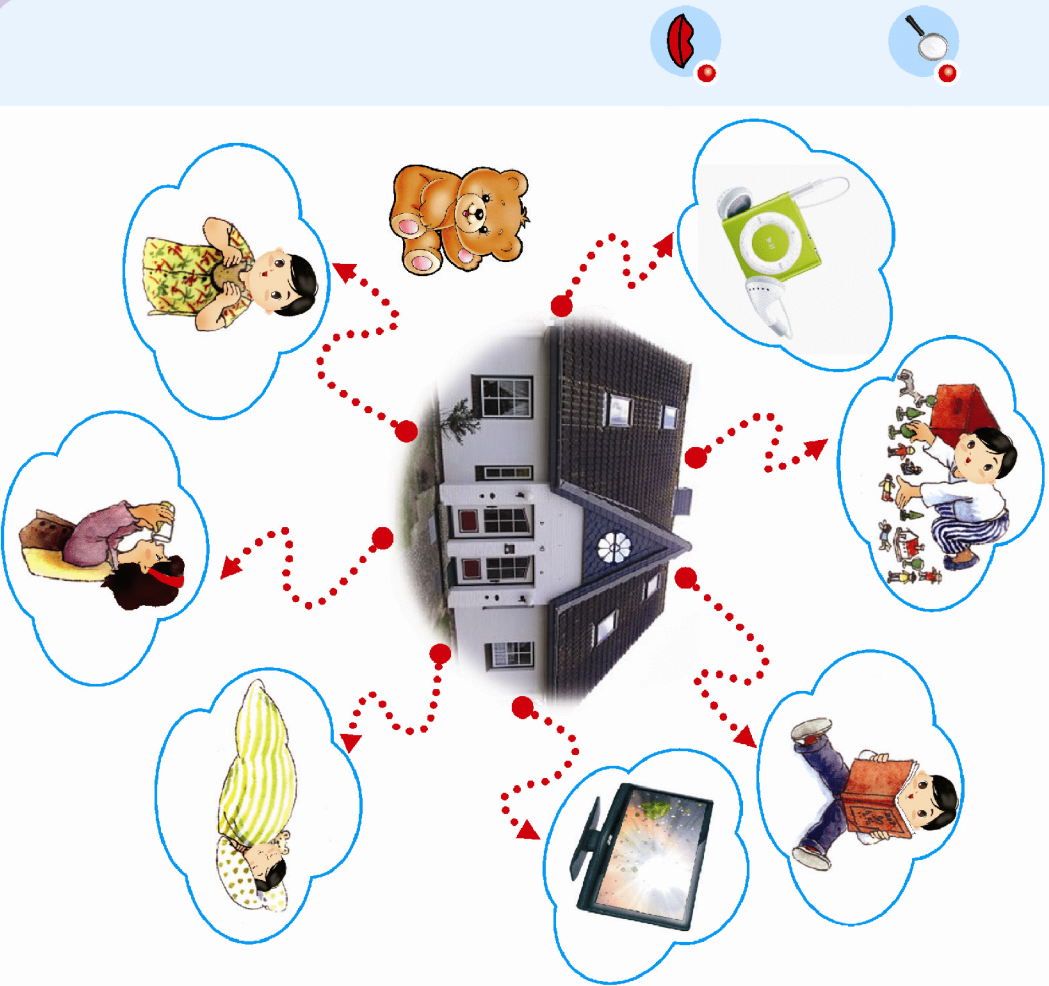

WAS KANN ICH... Zu Hause





14

WAS KANN ICH...
In der Klasse

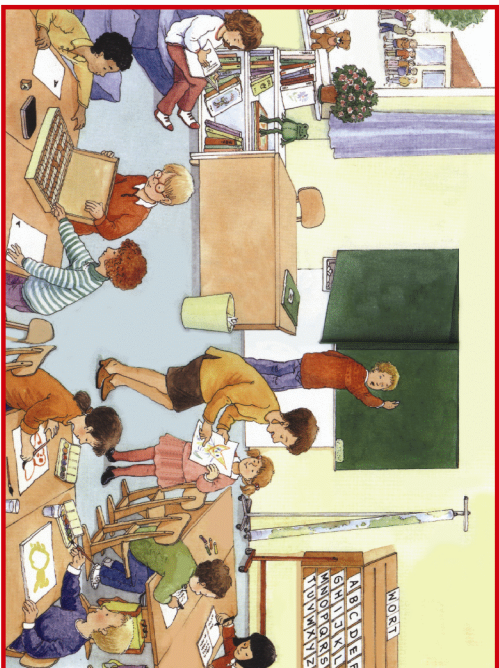

1

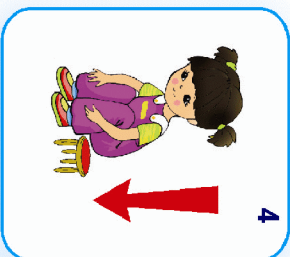

4



2



5

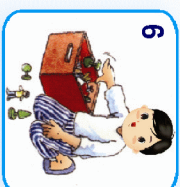

6



3

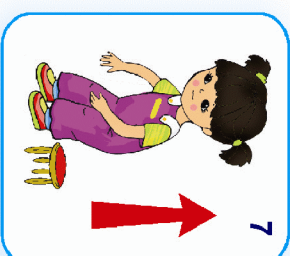

7

WAS KANN ICH...
In der Klasse

14

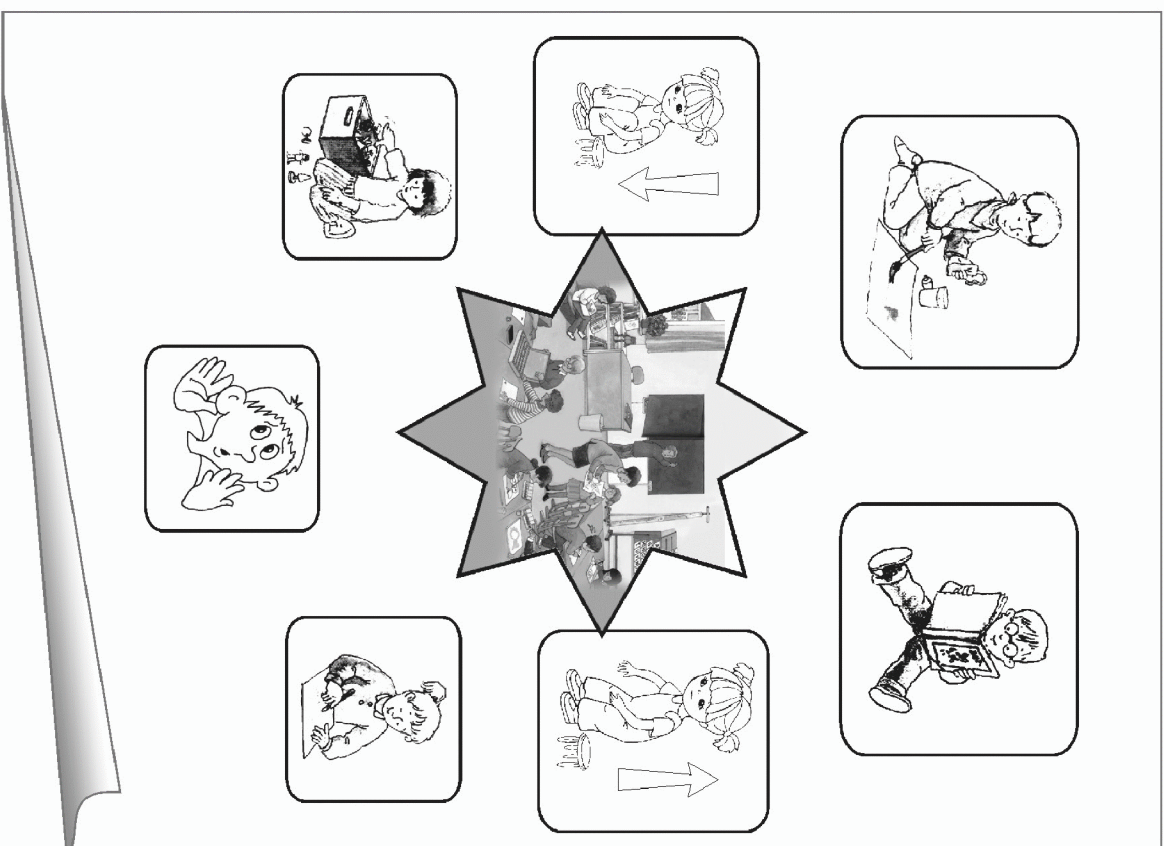

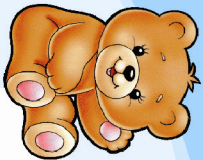

14

WAS KANN ICH...
In der Klasse

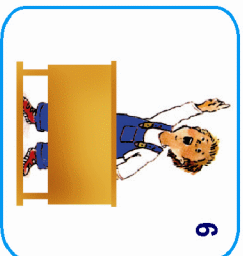
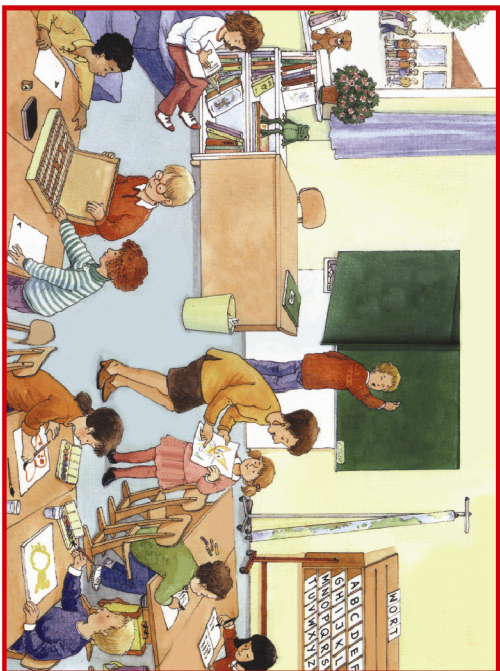

14

WAS KANN ICH...
In der Klasse

Activity area with smiley faces and illustrations for matching.

Smiley faces:

Illustrations:

Blue circles for matching:



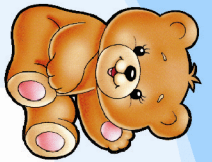

WAS KANN ICH...

Das kann ich

Das kann ich



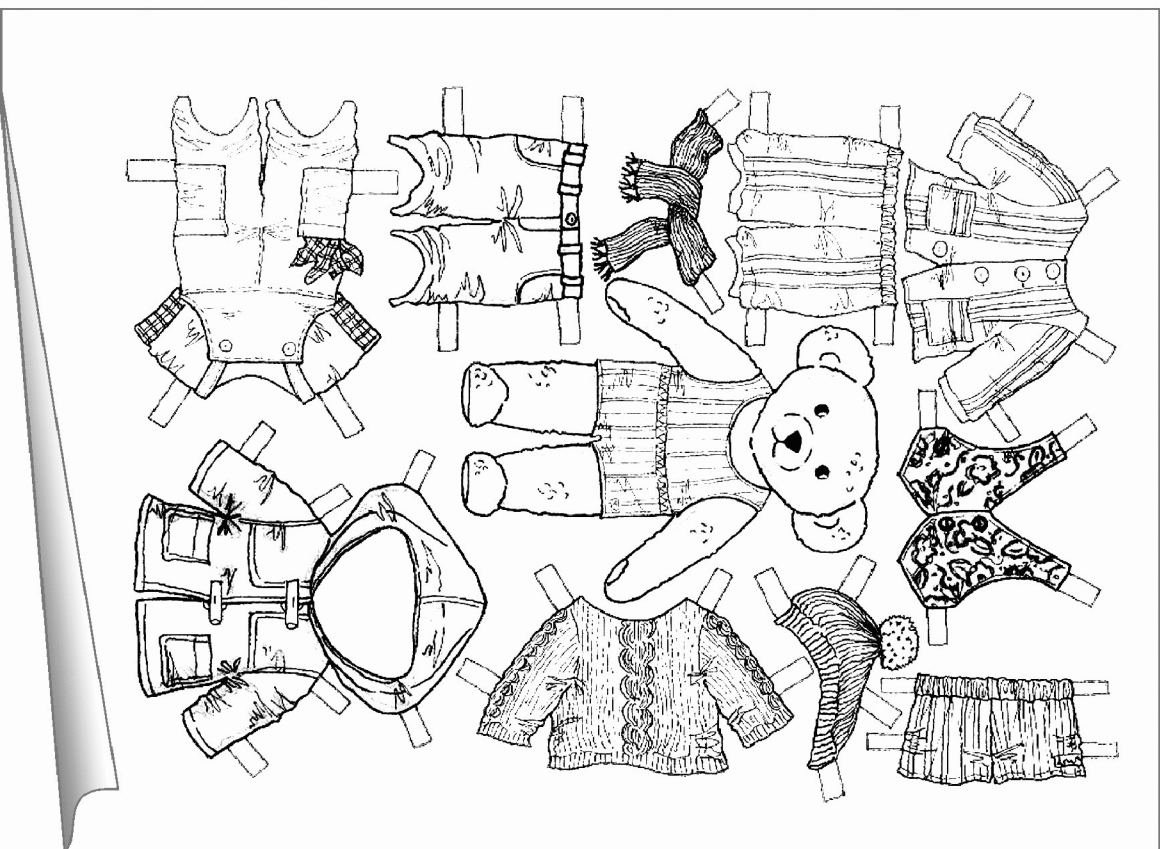
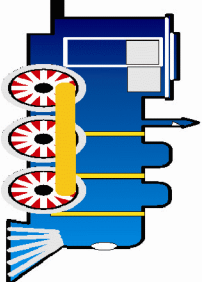



WIEDERHOLUNG

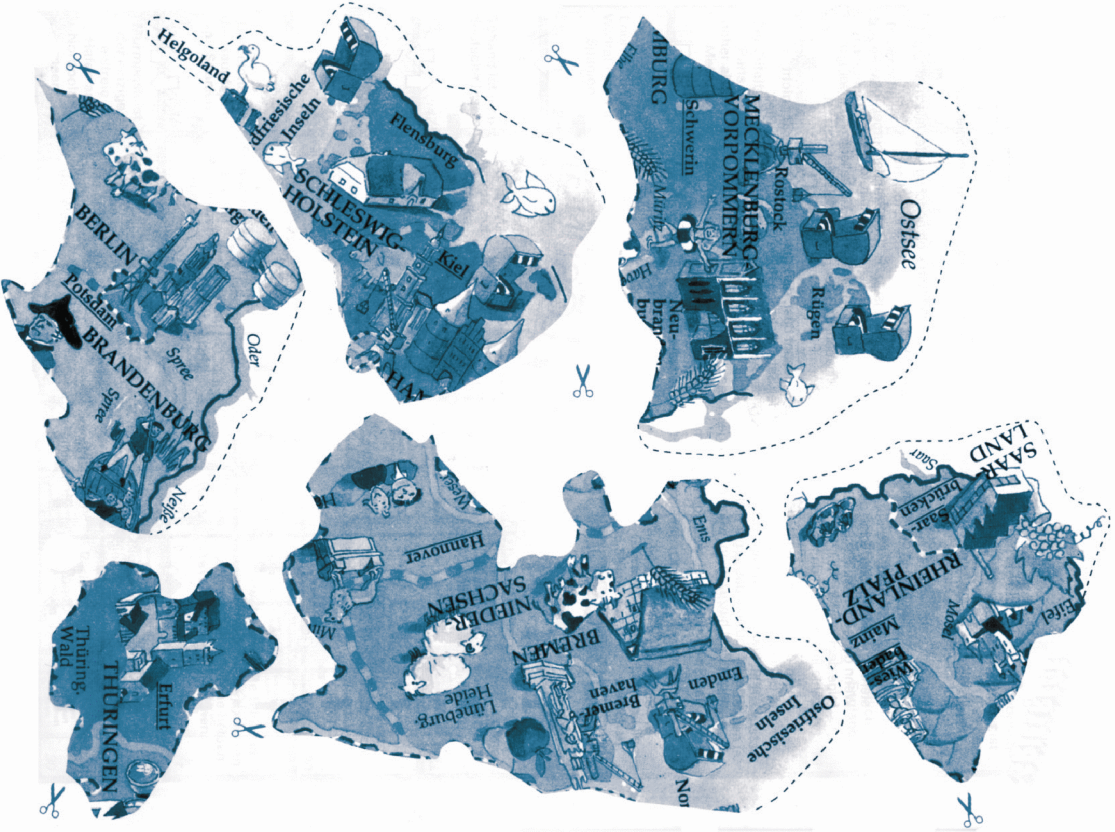

WIEDERHOLUNG

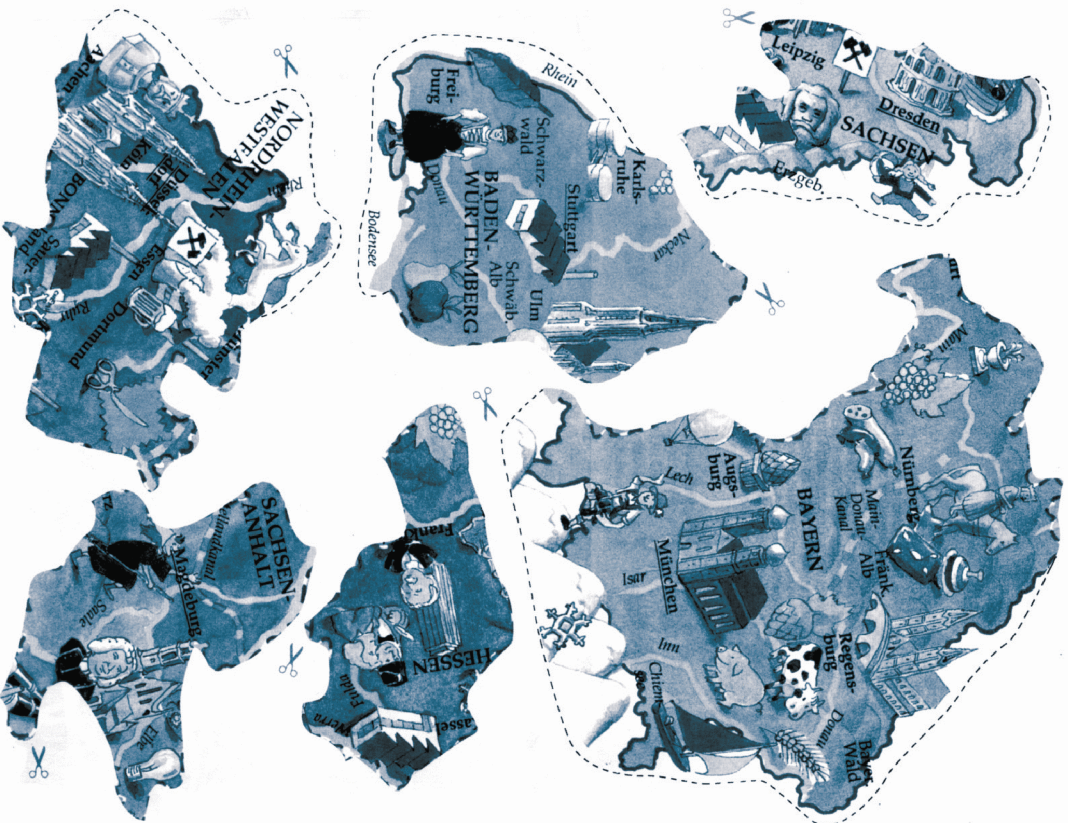

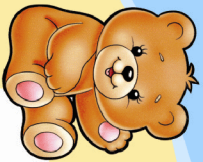

INHALTSVERZEICHNIS



INHALTSVERZEICHNIS

1-BEKANNTSCHAFT

Begrüßung.....	4
Sich verabschieden.....	6
Wie geht es?.....	8

2-ALLES ÜBER MICH

Sich vorstellen.....	12
Ich, du, er, sie, es.....	14
Wie alt bist du?.....	16
Wo wohnst du?.....	18

3-FAMILIE

Familie stellt sich vor.....	20
Wie heißt du?.....	22
Partnerarbeit.....	24
Meine Familie.....	26

4-MEIN FREUND

Mein Freund heißt.....	28
Mein Freund ist.....	30
Wohnort.....	32

5-FARBEN

Ist das Rot?.....	36
Gegenstände und Farben.....	38
Gegenstände und Farben.....	40
Farben und Formen.....	42

6-SPIELZEUGE

Mein Freund heißt.....	44
As fehlt?.....	46
Ich spiele gern.....	48

7-UMWELT

Bekanntschaft mit Natur.....	52
Bekanntschaft mit Natur.....	54
Jahreszeiten.....	56
Natur und wir.....	58

8-KÖRPERTEILE

Was ist das?.....	60
Mein Hampelmann.....	62
Am Morgen.....	64
Was tut weh?.....	66

9-MEIN KLASSENZIMMER

In der Klasse.....	68
Meine Schulsachen.....	70
Wer hat was?.....	72
Was habe ich in meiner Schultasche?	74

10-ZAHLEN

Wir zählen (1-10).....	76
Wir zählen (11-20).....	78
Welche Ziffer fehlt?.....	80
Wir zählen spielend.....	82

11-OBST UND GEMÜSE

Was ist das?.....	84
Nennt Obst und zählt!.....	86
Sortiere Obst und Gemüse!.....	88
Spiele.....	90

12-TIERE

Haustiere.....	92
Wildtiere.....	94
Wie ist die Katze?.....	96
Ich spiele gern.....	98

13-MÄRCHENWELT

Kennst du Märchenhelden?.....	100
Sich verabschieden.....	102
Wie geht es?.....	104

14-WAS KANN ICH...

Zu Hause.....	108
In der Klasse.....	110
In der Klasse.....	112
Das kann ich.....	114

DEUTSCH MACHT SPAR



DEUTSCH MACHT SPAR



Toshkent-2013